

DOC.NR.	REV	DATE	BY	DESCRIPTION
GM16656	-	7-7-2020	TM	ORIGINAL DRAWING

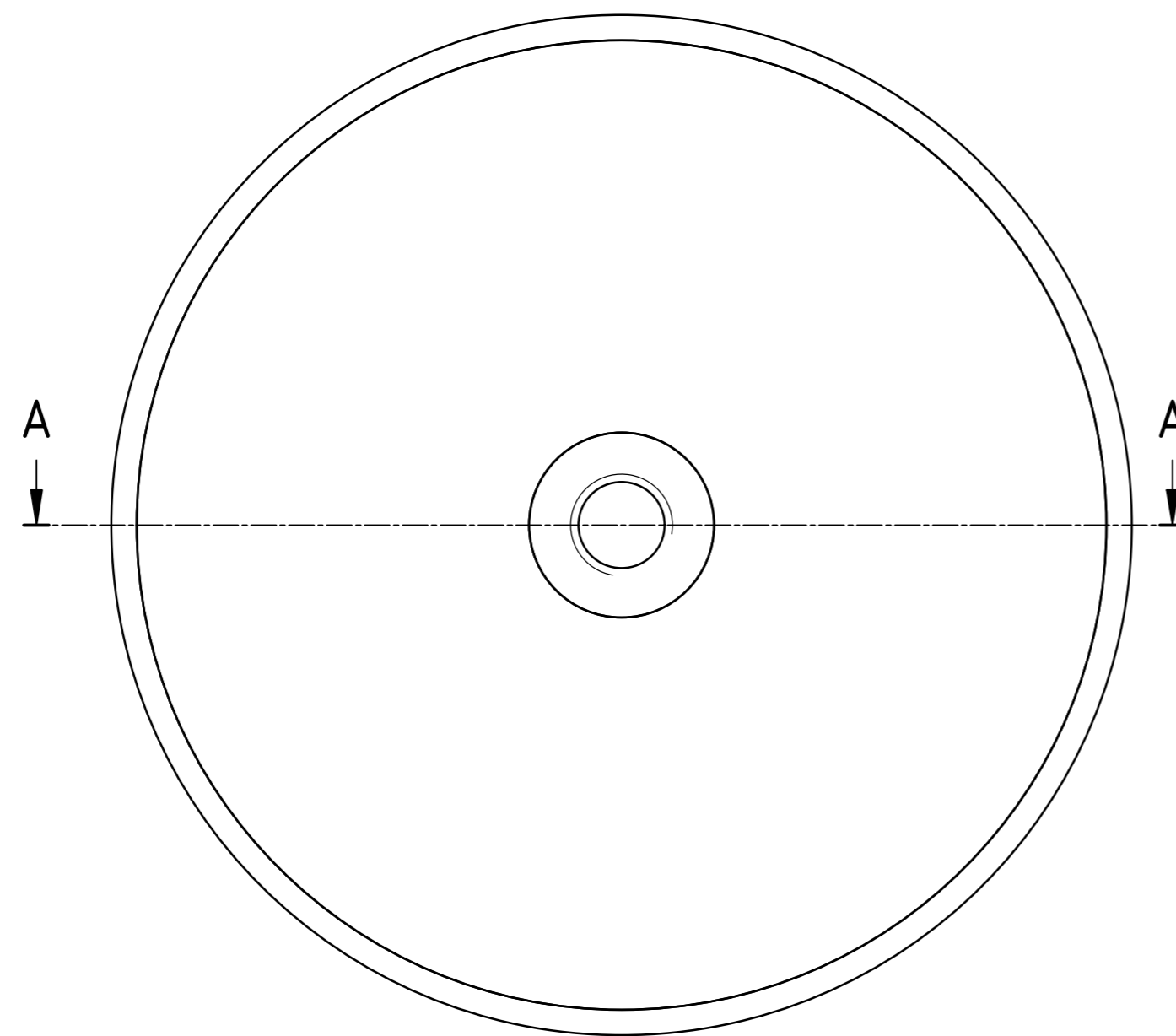

RAW MAT.	1								
Quantity		Material Number		Material Description		Length (mm)		Width (mm)	
Sheet:	A2	Extra info:	POTMAGNET SrFe	General tolerance:	ISO 2768 - mK				
Drawn:	TM	Weight (kg):	0,47	Drawn according:	ISO268; ISO1101; ISO2553				
Date:	7-7-2020			Status:	Standard				
Spare part:	False	Source:		Customer reference number:	F80D-VM8				
Quick search:	POTGM			Document number:	GM16656	Doc.Rev:			
Description:				Part number:	GM16656	Rev:			
					PM-TI-F-SG-D80x18xM8				

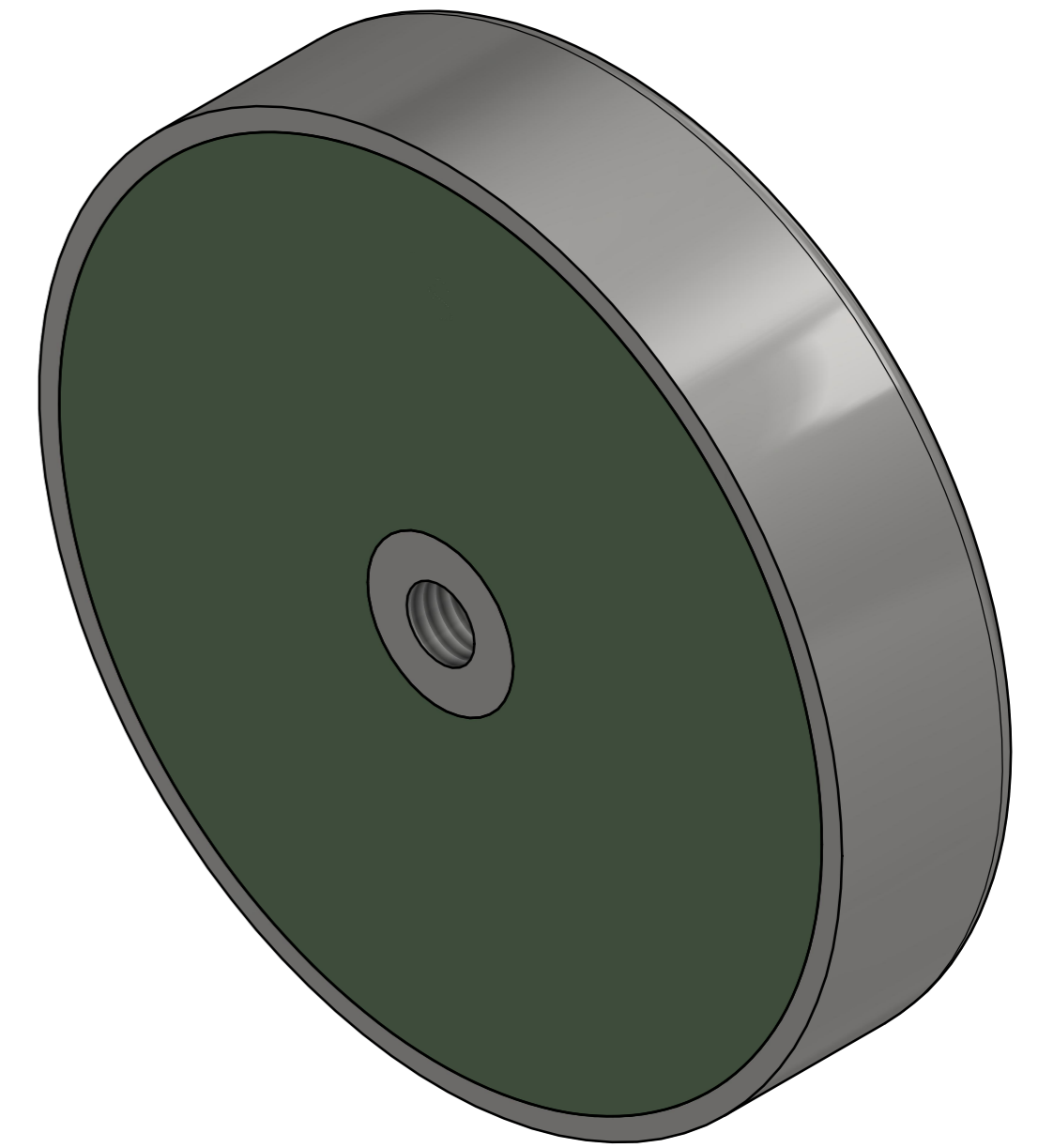
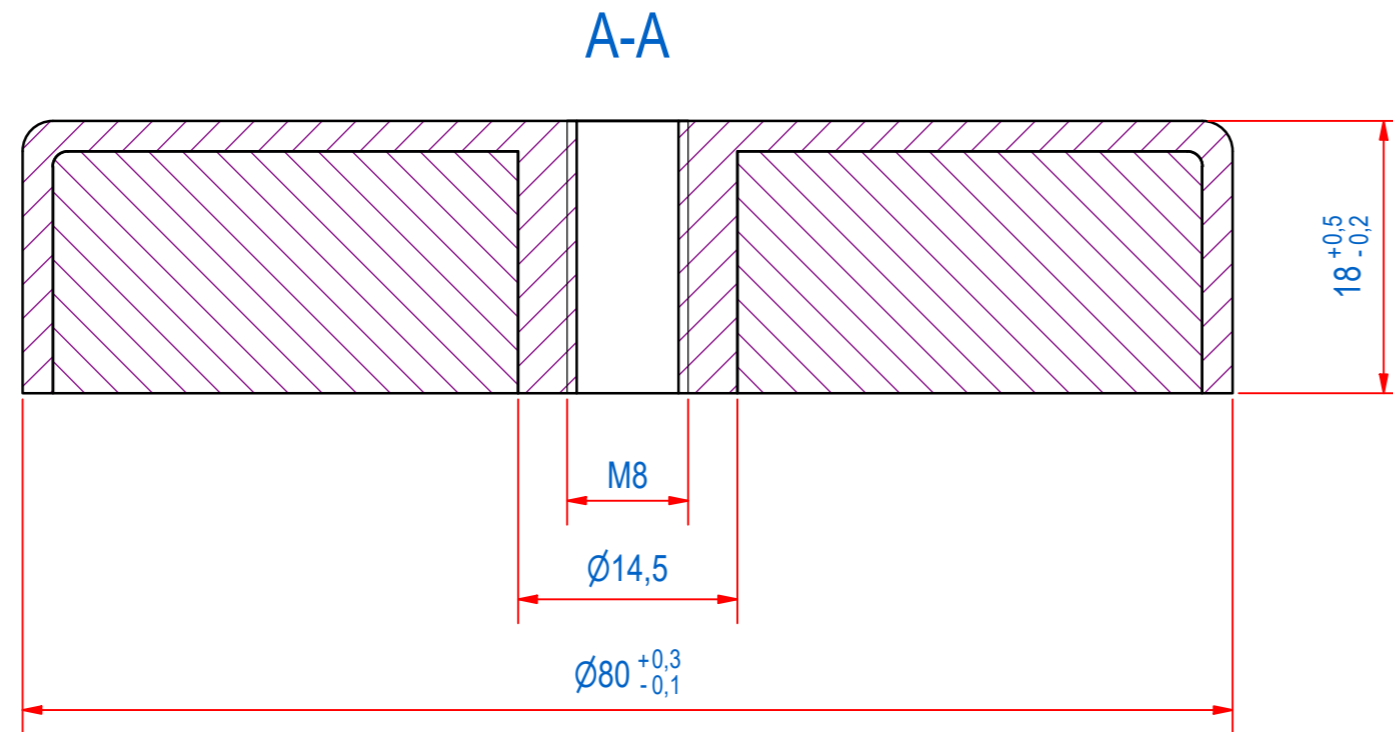

© All rights reserved. Reproduction is not permitted without written permission of GOUDSMIT Magnetic Systems BV