

DOC.NR.	REV	DATE	BY	DESCRIPTION
GM16703	-	25-9-2019	PV	ORIGINAL DRAWING

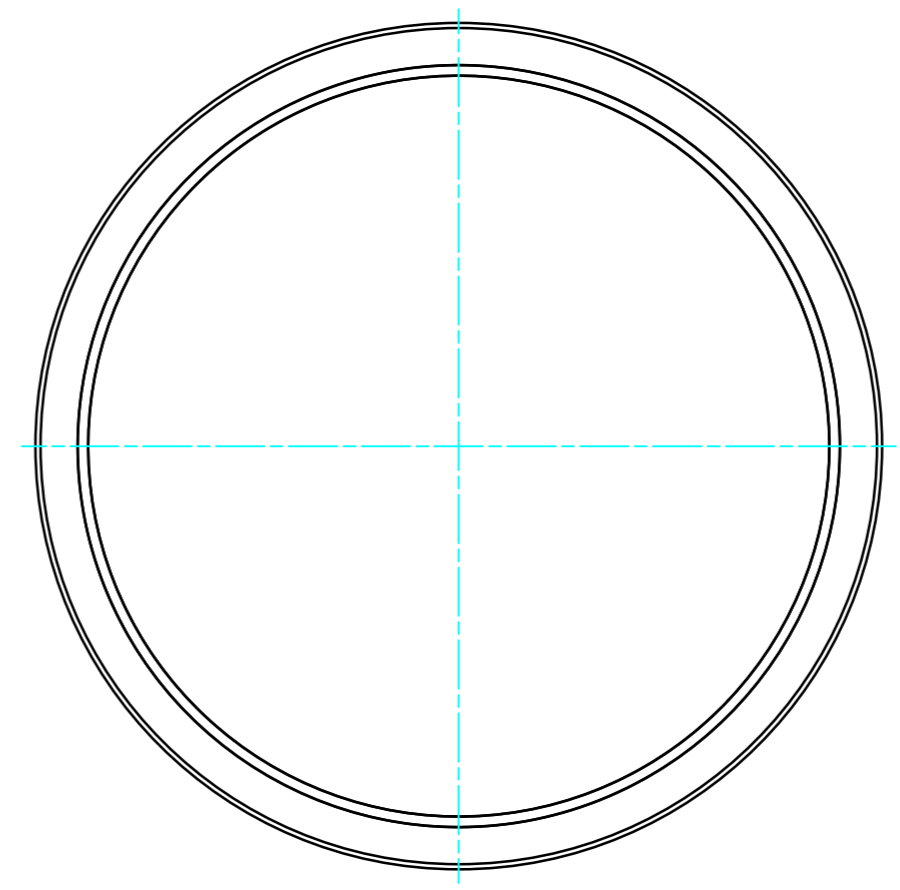
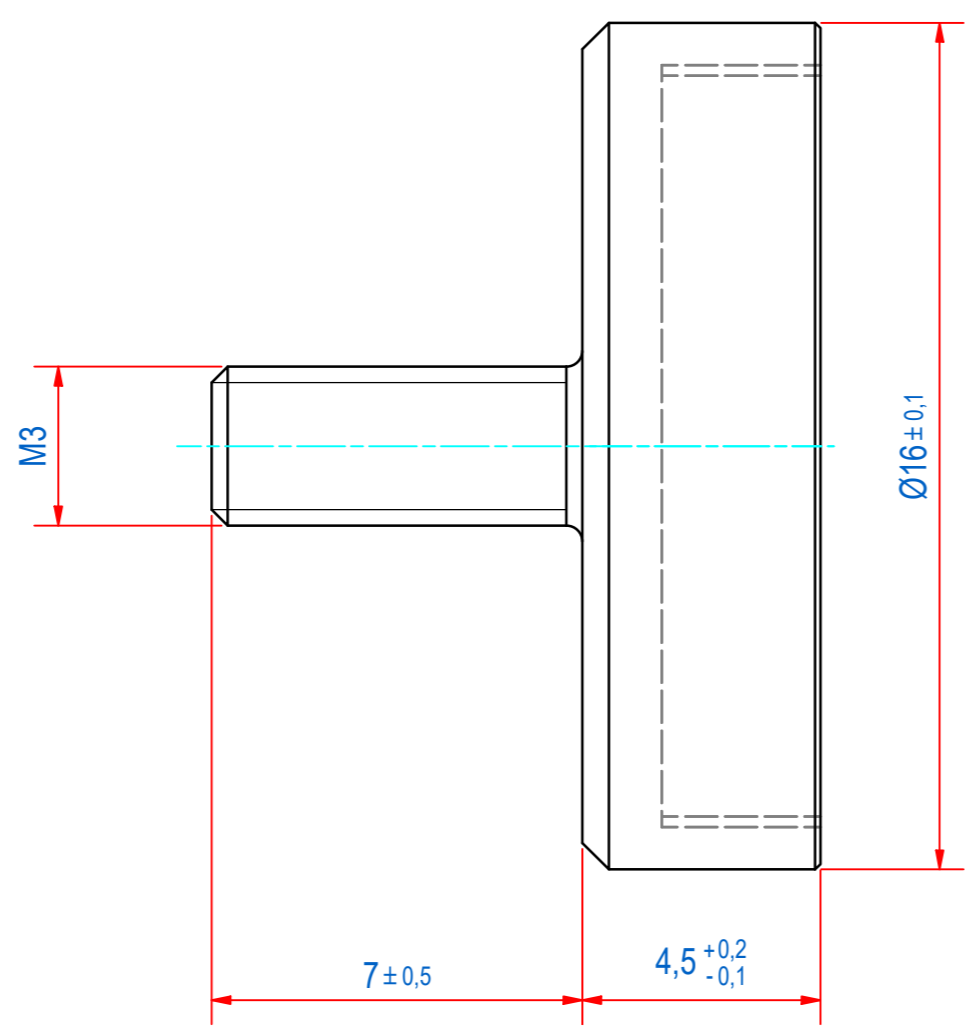
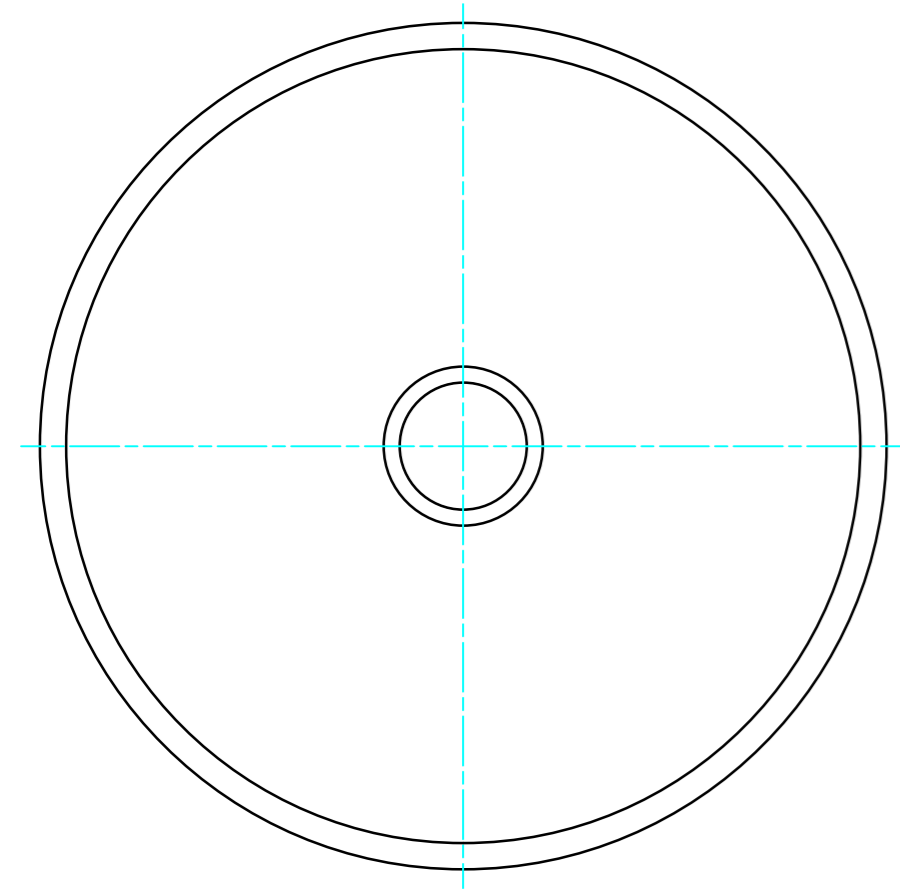
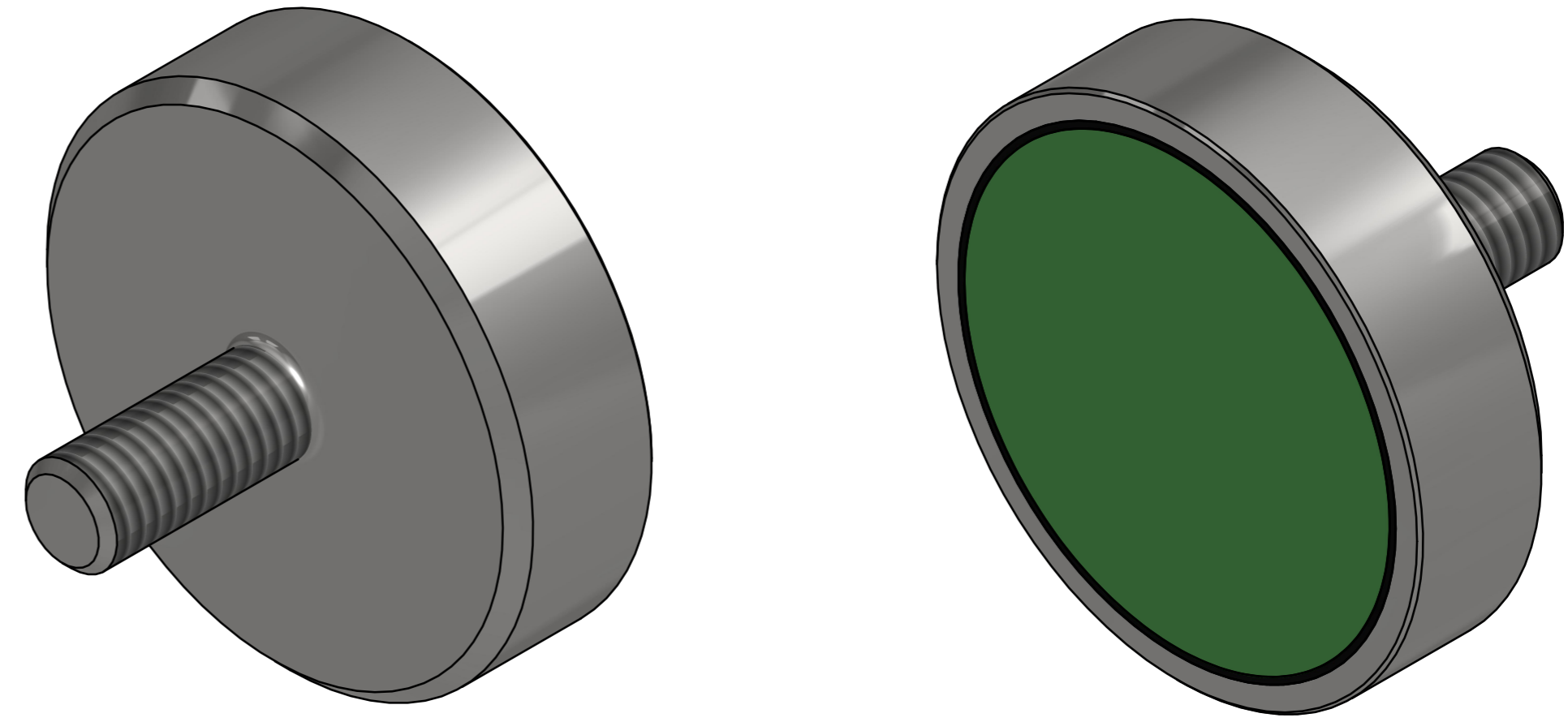

SURFACE TREATMENT: ZINC PLATED

RAW MAT.	1	Quantity	Material Number	Material Description	Length (mm)	Width (mm)
Sheet:	A2	Extra info:	POTMAGNET FERRITE		General tolerance: ISO 2768- mK	
Drawn:	PV	Weight (kg):	0,007		Drawn according: ISO268; ISO1101; ISO2553	
Date:	10-9-2019	Source:	GOUDSMIT MAGNETICS		Status: Standard	
Spare part:	False	Quick search:	POTGM	© All rights reserved. Reproduction is not permitted without written permission of GOUDSMIT Magnetic Systems BV	Document number:	GM16703
Description:	PM-TE-F-SG-D16x4.5xM3x7				Part number:	GM16703