

DOC.NR.	REV	DATE	BY	DESCRIPTION
E0121327	-	19-12-2019	PB	ORIGINAL DRAWING
E0121327	A	19-12-2019	PB	NOTHING CHANGED
GM17425	B	12-6-2020	TM	TEXT S-POLE ADDED

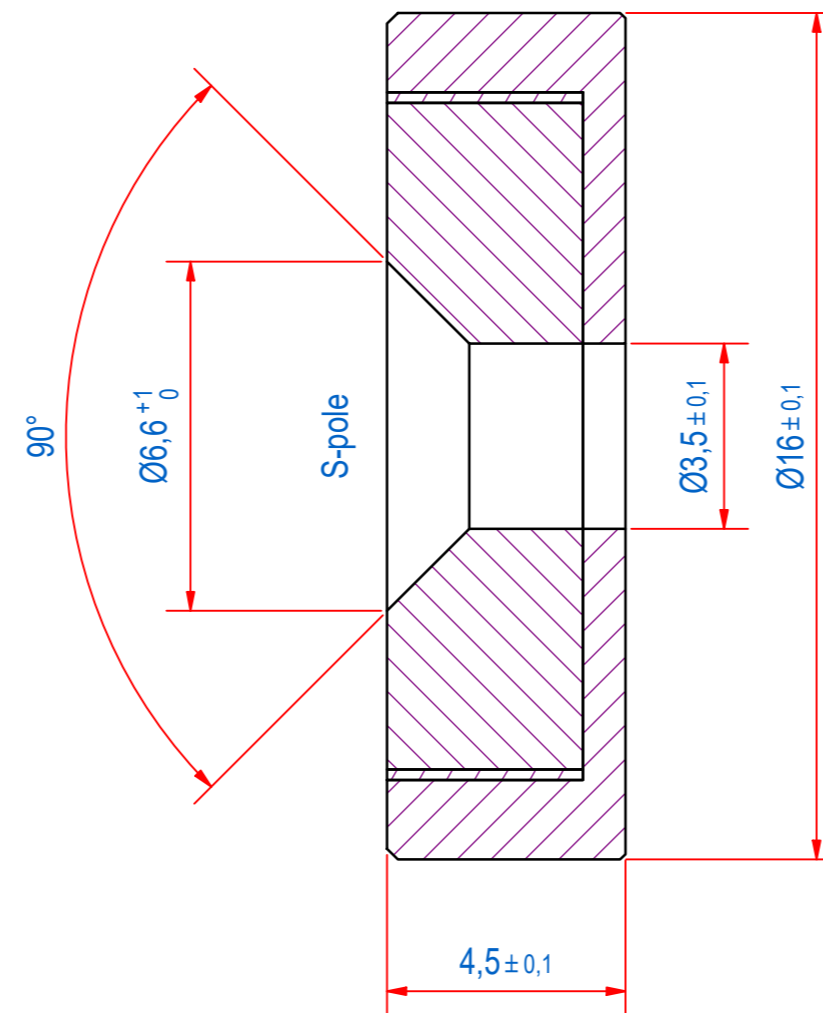

SURFACE TREATMENT: ZINC PLATED  
S-pole on open side

RAW MAT.	1								
Quantity		Material Number		Material Description		Length (mm)		Width (mm)	
Sheet:	A2	Extra info:	POTMAGNET NEODYMIUM		General tolerance:	ISO 2768- mK			
Drawn:	PV	Weight (kg):	0,006		Drawn according:	ISO268; ISO1101; ISO2553			
Date:	26-8-2019				Status:	Standard			
Spare part:	False	Source:			Customer reference number:				
Quick search:	POTGM				Document number:	GM17425	Doc.Rev:	B	
Description:	PM-HS-N-SG-D16x4.5x3.5/6.6-HQ				Part number:	GM17425	Rev:	A	

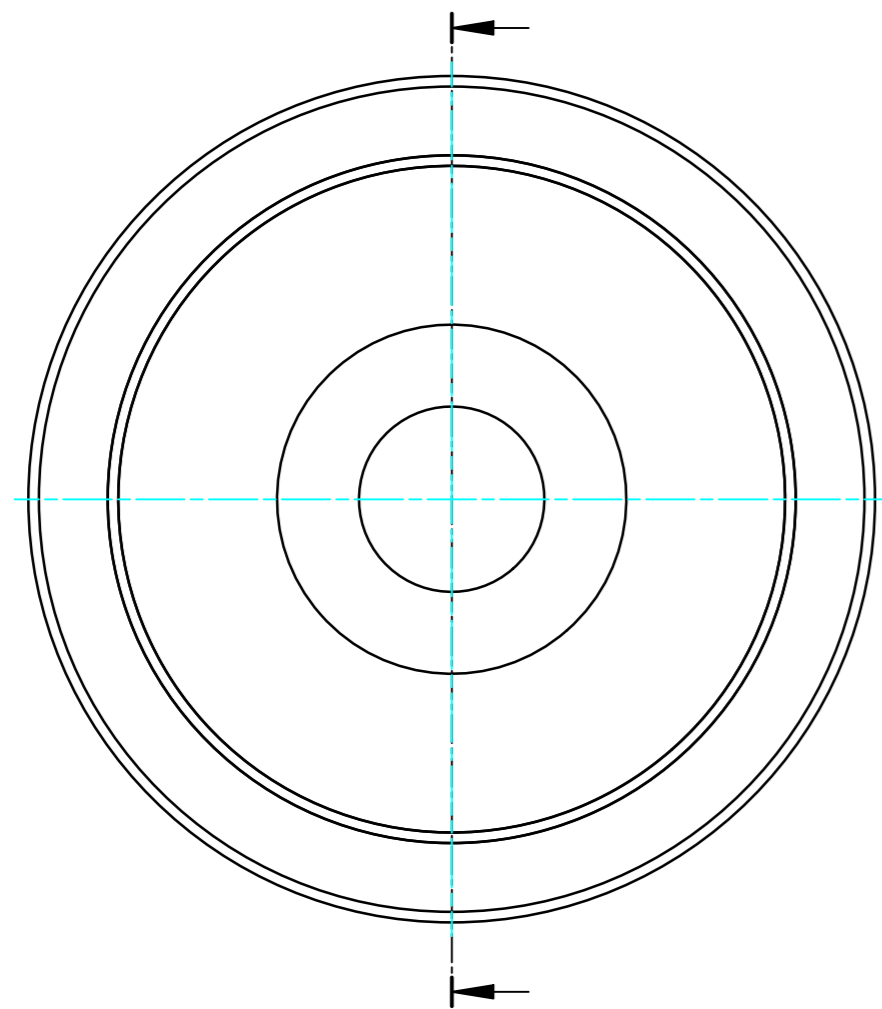
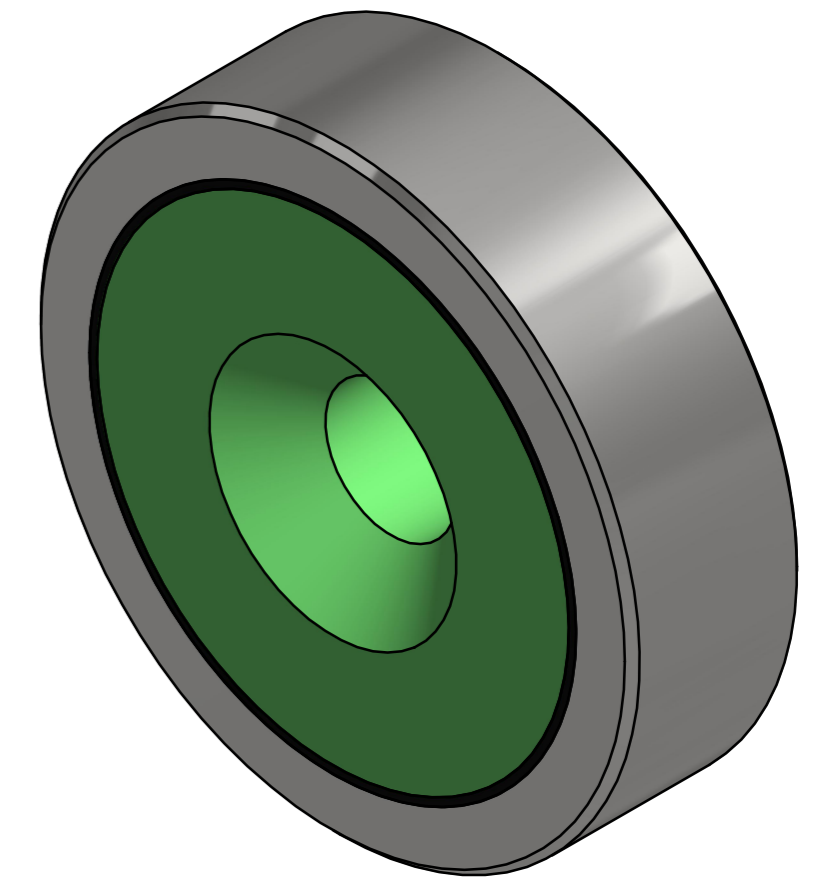
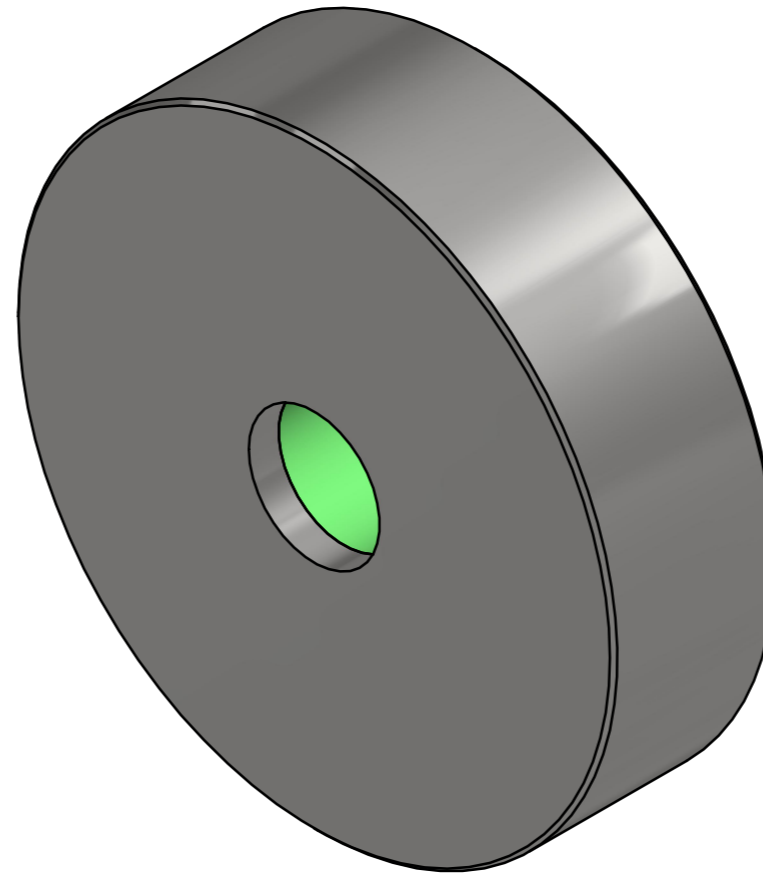

© All rights reserved. Reproduction is not permitted without written permission of GOUDSMIT Magnetic Systems BV