

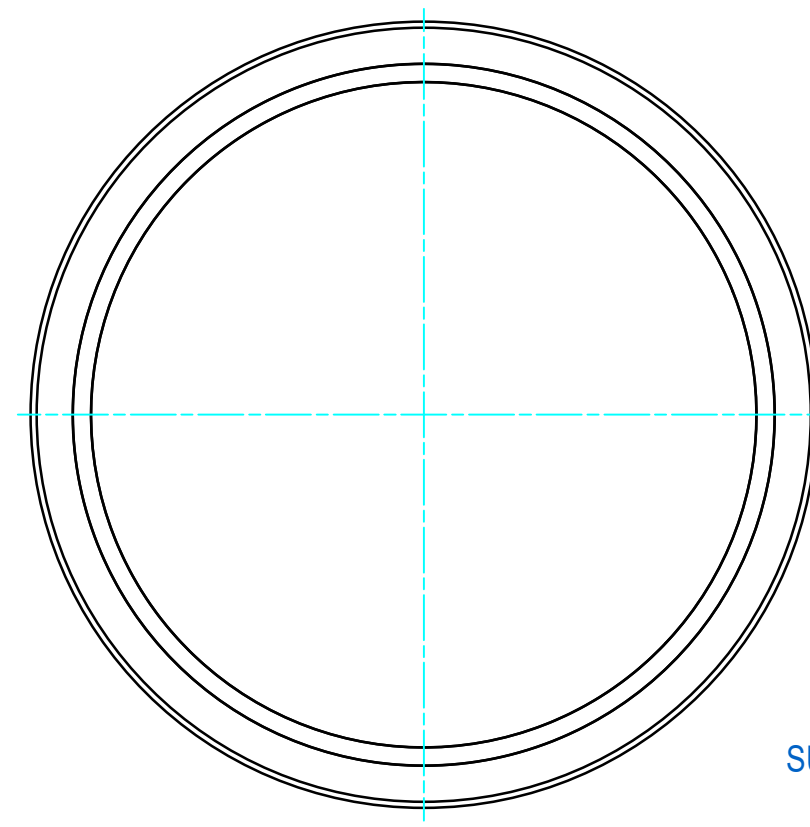

DOC.NR.	REV	DATE	BY	DESCRIPTION
E0119056	-	2-10-2019	PV	ORIGINAL DRAWING

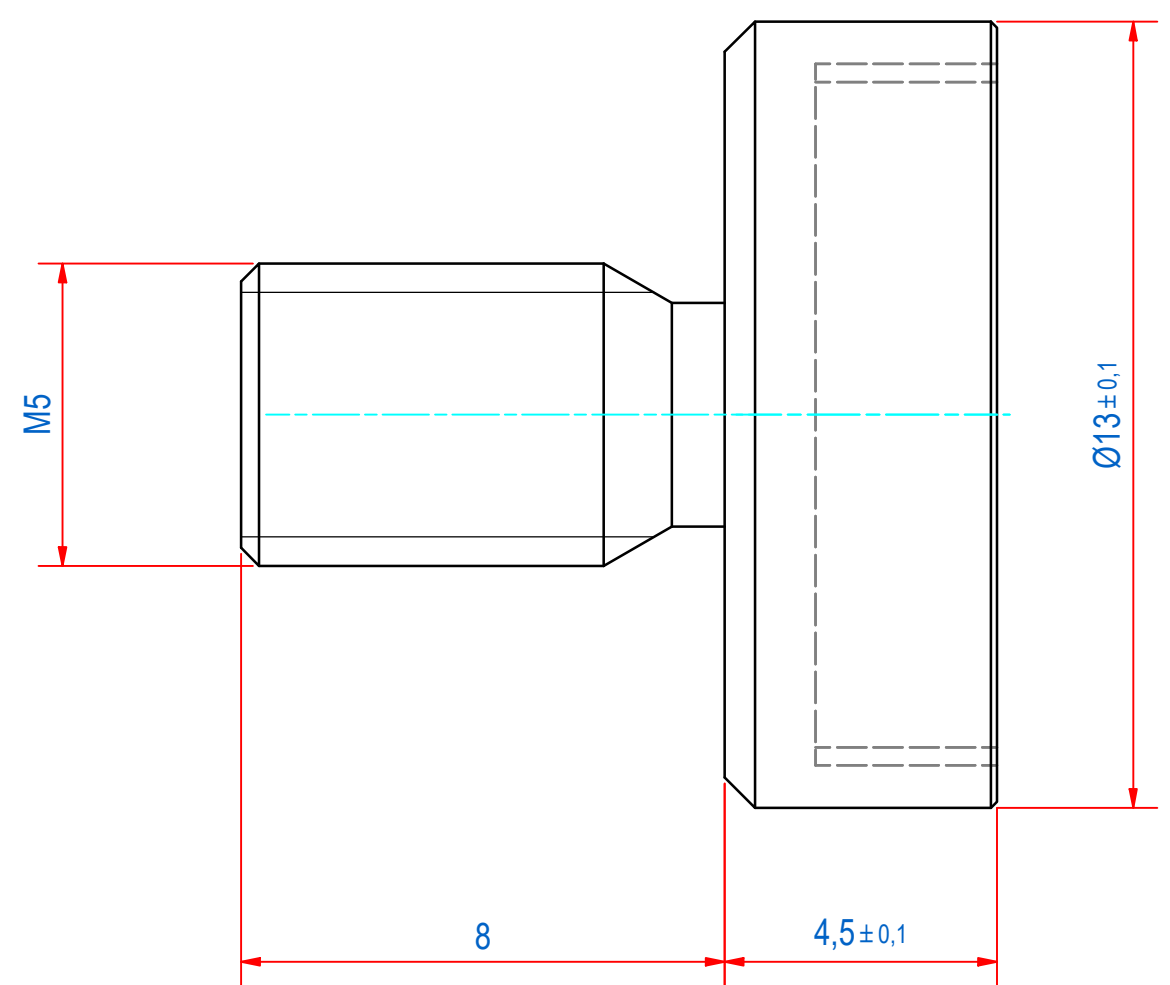
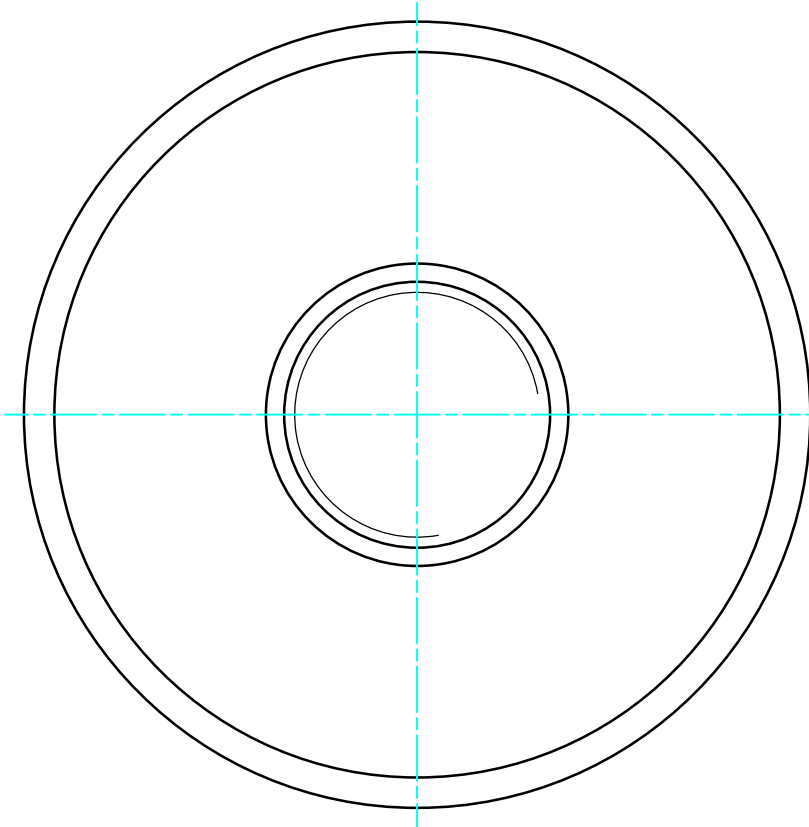
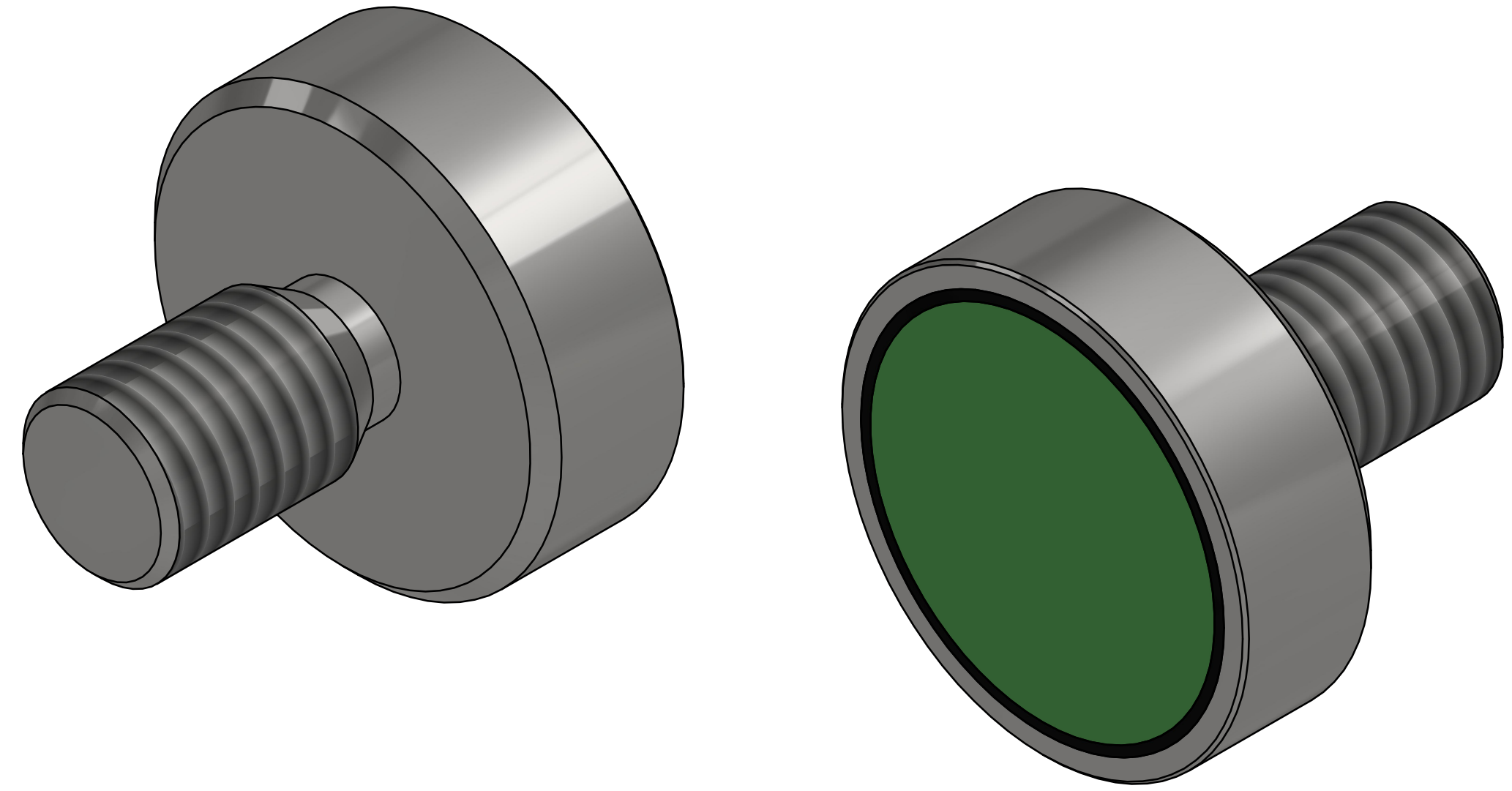

SURFACE TREATMENT: ZINC PLATED

RAW MAT.	1	Quantity	Material Number	Material Description	Length (mm)	Width (mm)
Sheet:	A2	Extra info:	POTMAGNET NEODYMIUM		General tolerance: ISO 2768- mK	
Drawn:	PV	Weight (kg):	0,006		Drawn according: ISO268; ISO1101; ISO2553	
Date:	17-7-2019	Status:	Standard		Customer reference number:	
Spare part:	False	Source:			Document number: E0119056 Doc.Rev: -	
Quick search:	POTGM	<small>© All rights reserved. Reproduction is not permitted without written permission of GOUDSMIT Magnetic Systems BV</small>		Part number: GM17623 Rev: -		
Description:	PM-TE-N-SG-D13x4.5xM5x8-HQ					