

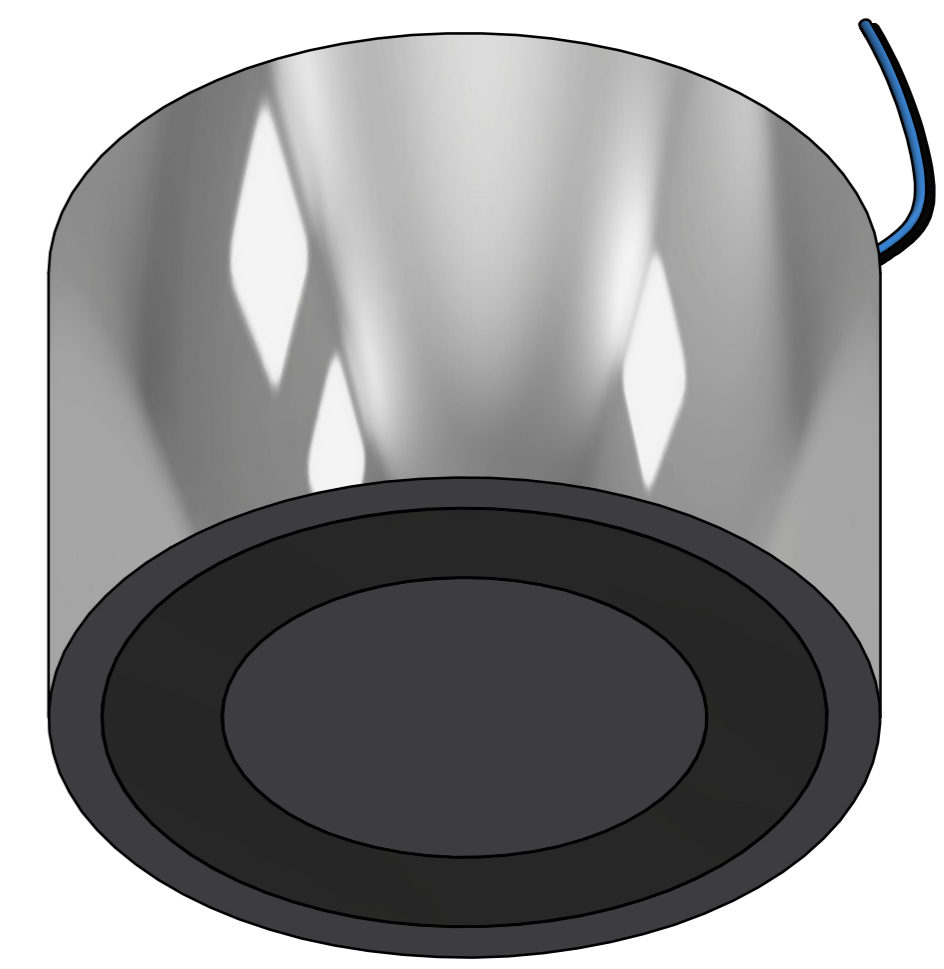

3	DOC.NR.	REV	DATE	BY	2	DESCRIPTION
	GM17855	-	19-11-2018	GS		ORIGINAL DRAWING

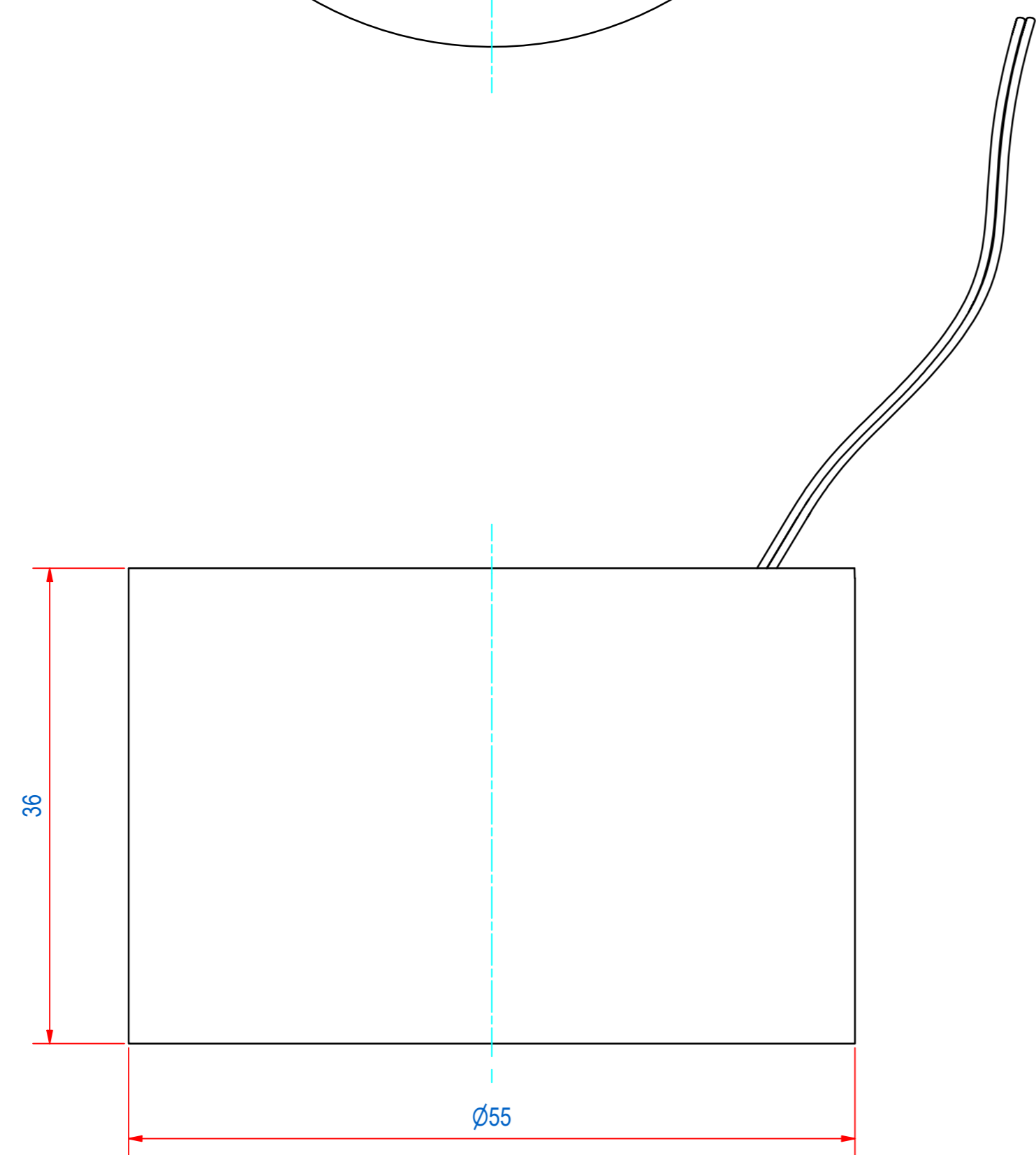
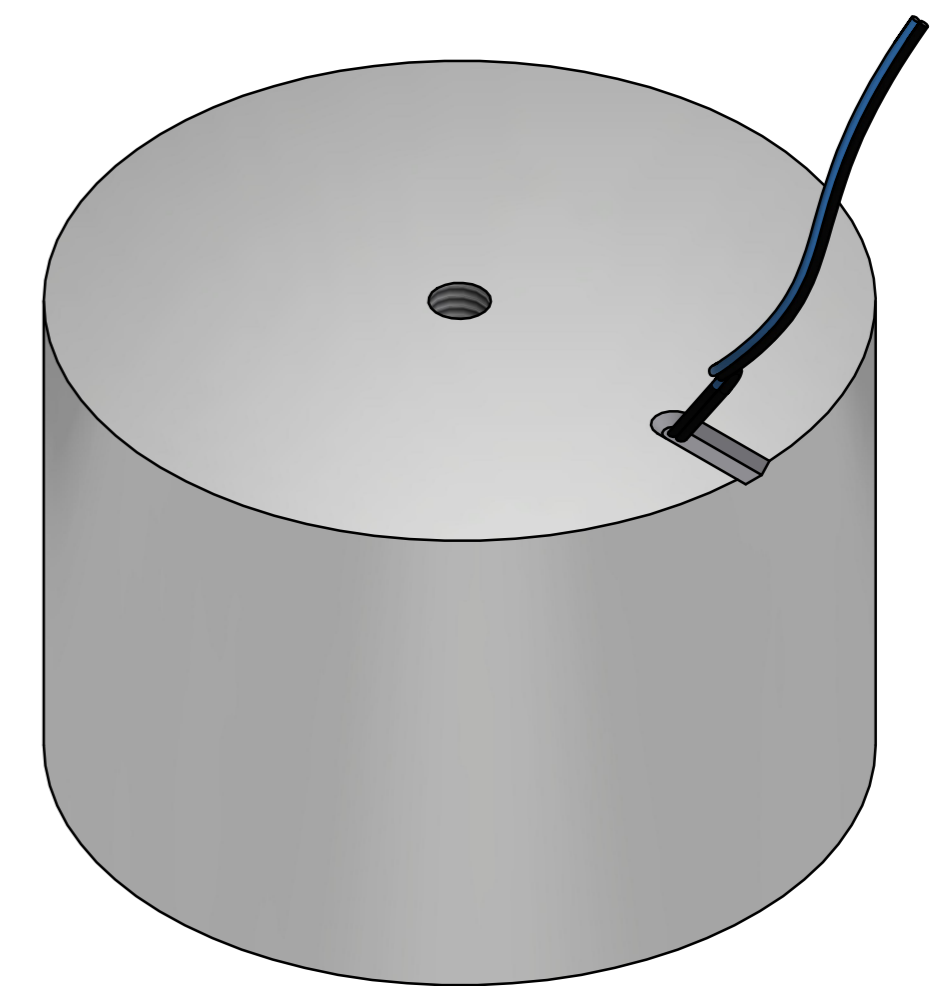
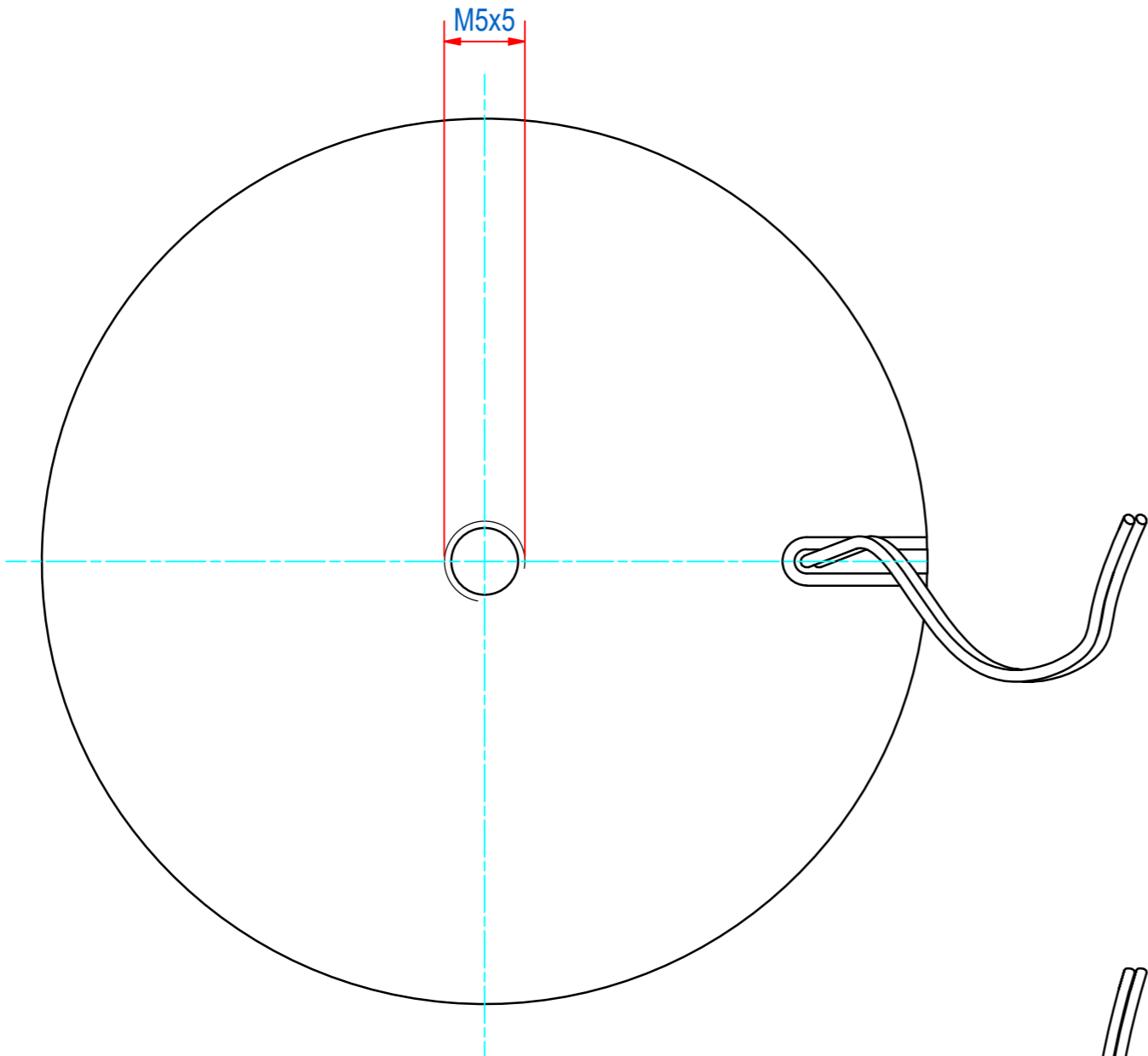

RAW MAT.	1	Quantity	Material Number	Material Description	Length (mm)	Width (mm)
⊕	Sheet:	A2	Extra info:	24VDC - 8.9W DUTY CYCLE 25%	General tolerance: ISO 2768 - mK	
GS	Weight (kg):	0,67	Drawn according:	ISO286; ISO1101; ISO2553		
Date:	19-11-2018	Status:	Standard			
Spare part:	False	Source:	MC-C	Customer reference number:		
Quick search:	EHRO0055				Document number:	GM17855
Description:	HEPM-EP-D055-036-SW				Part number:	GM17855
					Doc.Rev:	-
					Rev:	-