

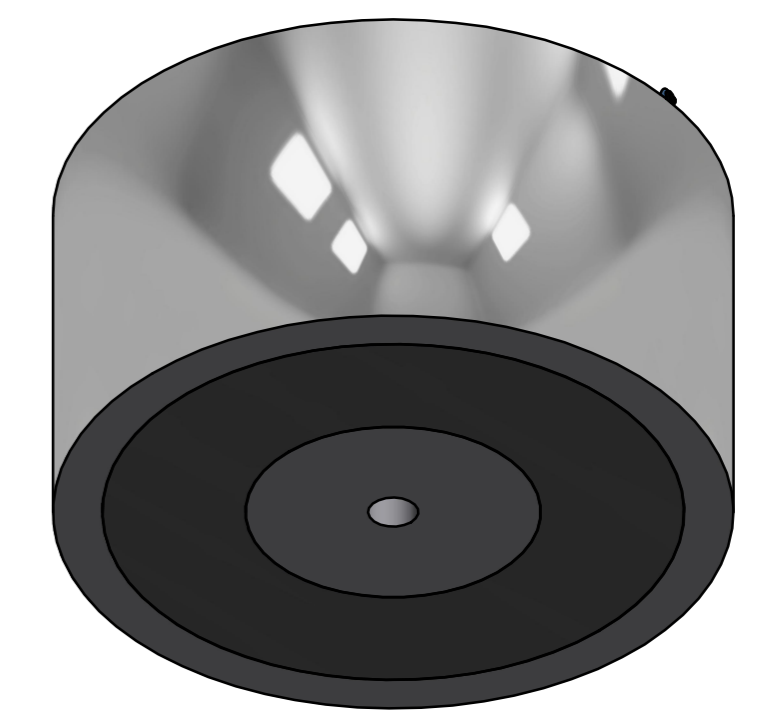

3	DOC.NR.	REV	DATE	BY	2	DESCRIPTION
	GM17859	-	19-11-2018	GS		ORIGINAL DRAWING

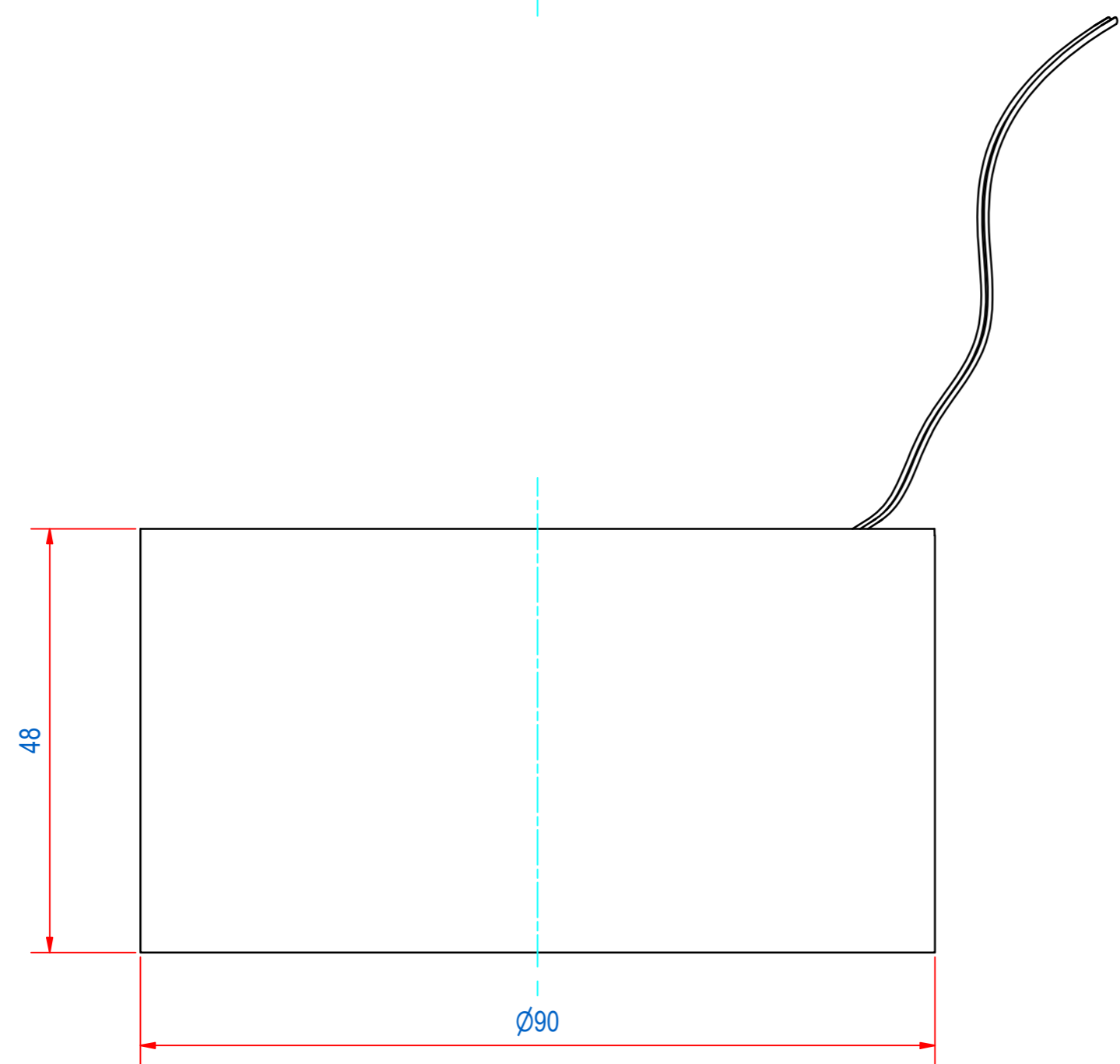
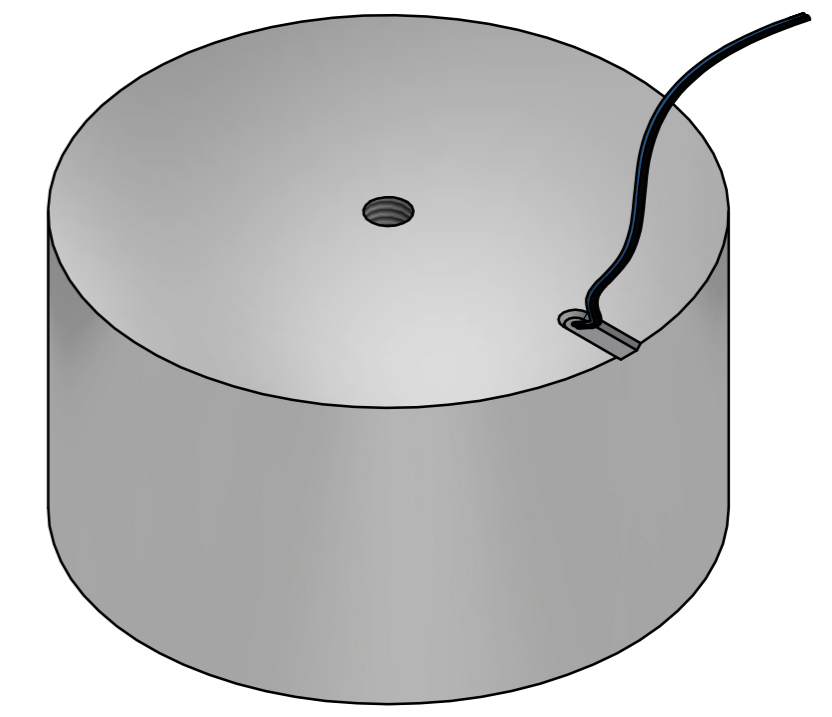
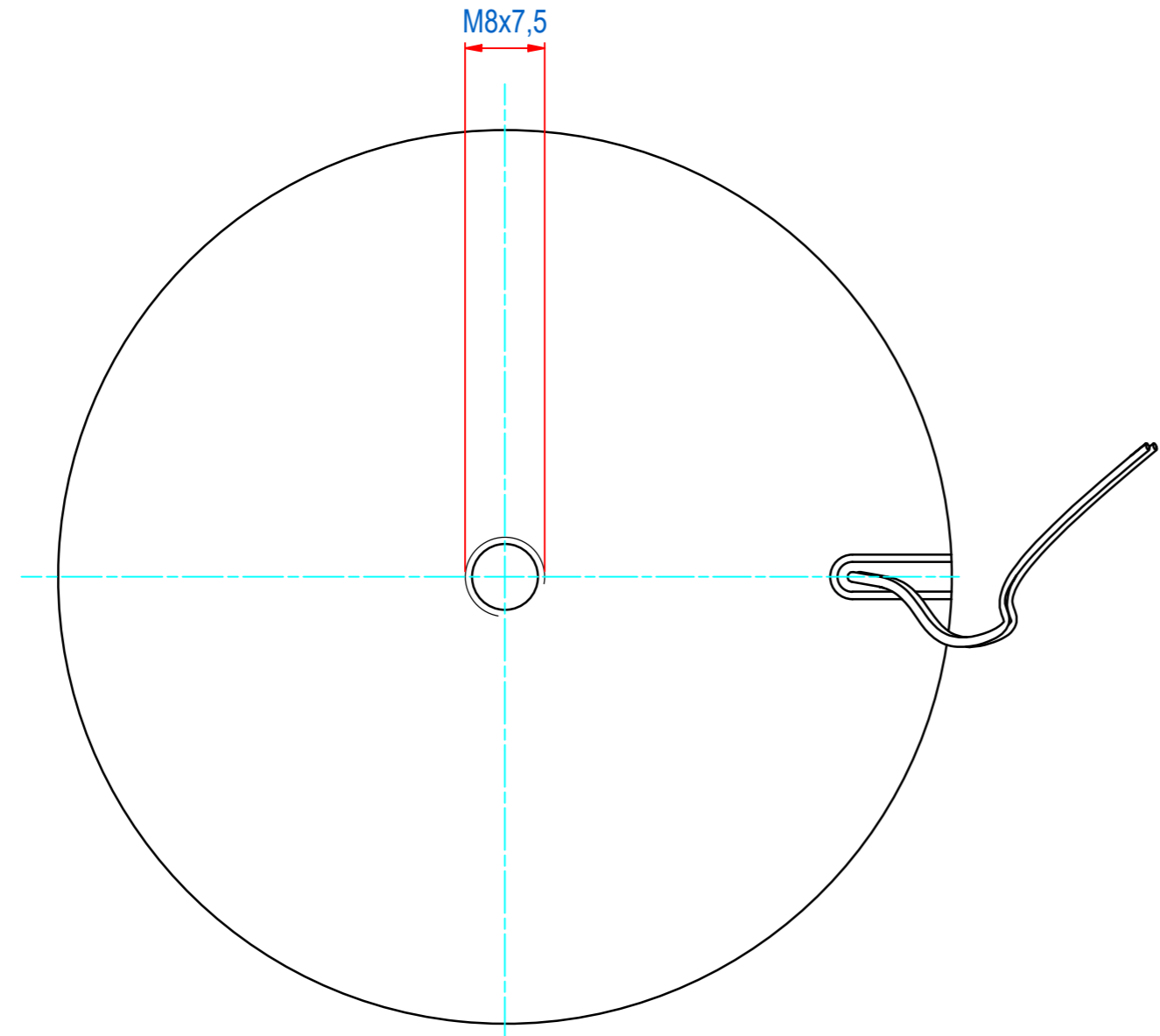

RAW MAT.	1	Quantity	Material Number	Material Description	Length (mm)	Width (mm)
Sheet:	A2	Extra info:	24VDC - 21,7W DUTY CYCLE 25%		General tolerance: ISO 2768 - mK	
Drawn:	GS	Weight (kg):	2,4	Drawn according to: ISO286; ISO1101; ISO2553		Status: Standard
Date:	19-11-2018	Spare part: False		Source: MC-C		Customer reference number:
Quick search:	EHRO0090				Document number: GM17859 Doc.Rev: -	
Description:	HEPM-EP-D090-048-SW				Part number:	GM17859 Rev: -