

## Installation and user manual

### Pipe magnets, SPN series

Permanent magnetic filter for powders and granulates in free-fall chutes.

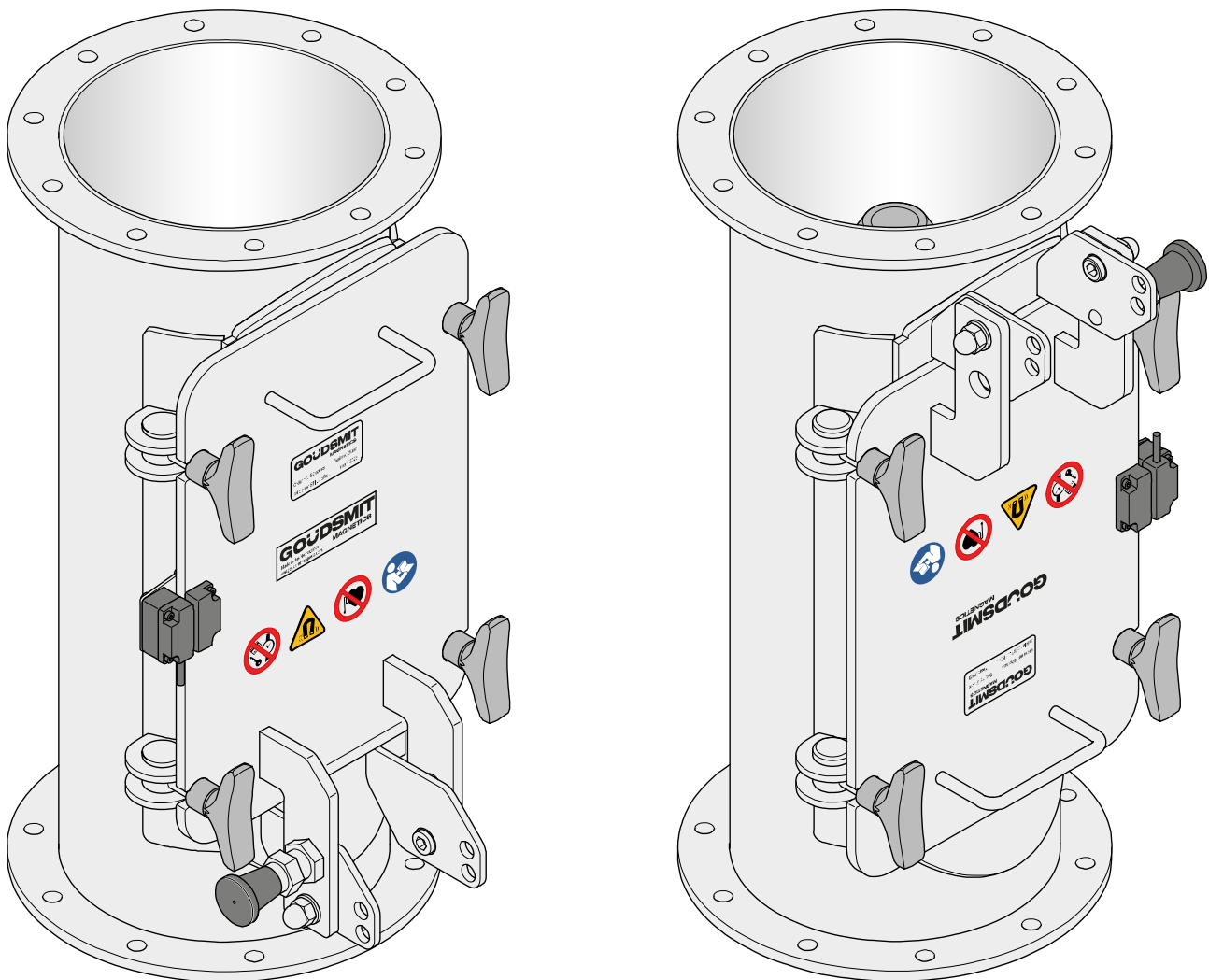

© Copyright. All rights reserved.

## Table of contents

<b>1 Introduction</b> .....	<b>5</b>
<b>2 Safety</b> .....	<b>6</b>
2.1 Safety risks.....	6
2.2 General safety instructions.....	6
2.3 Damage due to magnetic field .....	6
2.4 Other remarks/warnings.....	6
<b>3 Standards and regulations</b> .....	<b>7</b>
3.1 Limit values for occupational and public exposure to permanent magnetic and electromagnetic fields.....	7
<b>4 Specifications</b> .....	<b>9</b>
4.1 Range of application .....	9
4.2 Description of function.....	9
4.3 Flow rate .....	9
4.4 Use in food product flows.....	9
4.5 Temperatures .....	9
4.6 Free space .....	9
4.7 Aansluitspanning.....	9
4.8 ATEX (if applicable) .....	9
<b>5 Product information</b> .....	<b>10</b>
5.1 Construction .....	10
5.2 Scope of delivery.....	10
5.3 Identificatieplaat .....	11
5.4 Service life.....	11
5.5 Pressure test .....	11
5.6 Door sensor.....	11
5.6.1 Door switch .....	12
<b>6 Transport and installation</b> .....	<b>13</b>
6.1 Transport.....	13
6.2 Installation .....	14
6.3 Preventing electrostatic discharges (earthing).....	15
<b>7 Working principle</b> .....	<b>16</b>
7.1 General .....	16
7.2 Cleaning process – disposal of ferromagnetic particles.....	16
<b>8 Maintenance and inspection</b> .....	<b>18</b>
8.1 General guidelines .....	18
8.2 Frequency of maintenance.....	19
8.3 Cleaning instructions.....	19
8.4 Flux density measurement of the magnetic bar .....	19
8.5 Replacing seal.....	20
<b>9 Troubleshooting</b> .....	<b>22</b>
9.1 Troubleshooting table.....	22

**10 Service, storage and disassembly..... 23**

- 10.1 Customer service ..... 23
- 10.2 Spare parts..... 23
- 10.3 Storage and disposal ..... 23

## 1 Introduction

This manual contains information about correct use and maintenance of the device. The manual contains instructions that should be followed to prevent injury and serious damage and to ensure safe and problem-free operation of the device. Read this manual thoroughly and ensure that you fully understand everything before using the device.

If you need more information or still have questions, please contact Goudsmit Magnetic Systems B.V.. The contact details are provided on the title page of this manual. Additional copies of the manual can be ordered by providing the device description and/or article number as well as the order number.

In this manual, the SPN bullet magnet is further referred to as “device”.



### NOTICE

**Read this manual carefully before installation and commissioning!**

**The descriptions and figures in this manual, provided for explanatory purposes, may differ from the descriptions and figures of your version.**



### NOTICE

This manual and manufacturer’s declaration(s) are to be considered part of the device. Both documents must remain with this device if it is sold.

The manual must be available to all operating personnel, service technicians and others who work with the device throughout the life of the device.

## 2 Safety

### 2.1 Safety risks

This chapter describes the safety risks of the device. Where necessary, warning pictograms have been affixed to the device. These pictograms are explained later in this document.



#### NOTICE

Observe the following measures:

- ▶ Read the warning pictograms on the device carefully.
- ▶ Check that the pictograms on the device are present and legible at regular intervals.
- ▶ Keep the pictograms clean.
- ▶ Replace pictograms that have become illegible or that have been removed with new pictograms in the same locations.

### 2.2 General safety instructions

- The instructions in this manual must be complied with. If they are not, there is a risk of material damage, personal injury and even a danger of death.
- The device may only be used to filter powders and granulates. Any other use is inconsistent with the regulations. Any resulting damage is not covered by the factory warranty.
- Ensure that people who work on the device or in its immediate vicinity wear adequate protective equipment.
- Impose additional safety measures and use additional warning pictograms if the device remains easily accessible to people. If this is not possible, ensure that clear instructions are provided for the entire system in which this device is integrated.
- Work on the device may only be carried out by qualified personnel. Ideally, maintenance work on the magnets should be carried out by Goudsmit Magnetic Systems B.V. personnel.
- Always take locally applicable safety and environmental regulations into account.

### 2.3 Damage due to magnetic field

The magnets generate a powerful magnetic field that attracts ferromagnetic particles. This also applies to ferrous materials that may be carried on the person, including keys, coins and tools. When working within the magnetic field, use non-ferromagnetic tools and workbenches with a wooden worktop and non-ferromagnetic base.



#### WARNING

##### Strong magnetic field

Make sure your fingers and other body parts do not get caught between the magnetic components.

### 2.4 Other remarks/warnings

Rectify all faults before operating the device. If the device is used whilst exhibiting a fault, after having completed a risk assessment, warn operating and maintenance personnel of the fault and the potential risks associated with that fault.

### 3 Standards and regulations

#### 3.1 Limit values for occupational and public exposure to permanent magnetic and electromagnetic fields

The limit values and magnetic fields are defined in accordance with the EMC Directive EMC Directive 2013/35/EU as follows:

*Directive 2013/35/EU of the European Parliament and of the Council of 26 June 2013 on the minimum health and safety requirements regarding the exposure of workers to the risks arising from physical agents (electromagnetic fields).*

Observe the following measures in relation to exposure to magnetic fields in accordance with EN12198-1 (machine category = 0, no restrictions) of the device:

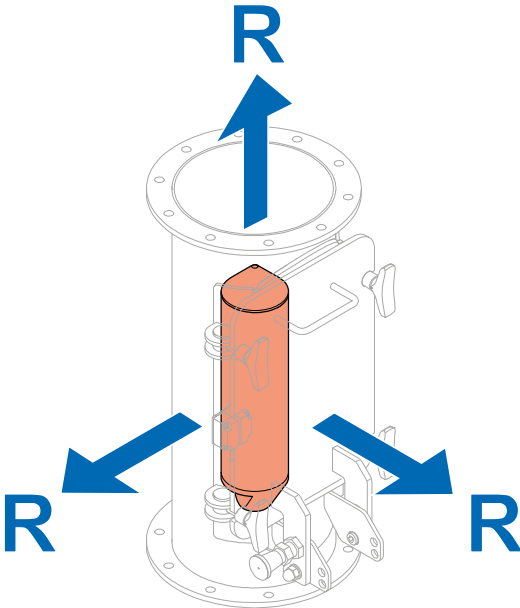

**Life-threatening danger to people with implanted medical aids**

People with an active implanted medical aid (e.g. pacemaker, defibrillator, insulin pump) must not be present within a radius 'R' of 1 metre(s) of the device.



**Damage to products with sensitivity to magnets**

Products that contain ferromagnetic parts, such as debit cards, credit or chip cards, keys and watches, may be rendered permanently damaged if they come within a radius 'R' of 0.2 metre(s) of the device.



Employees who are pregnant and the general public may not come within a radius 'R' of 0.1 metres of the device.



**WARNING**  
**Projectile hazard**

Ferromagnetic objects will be attracted if they come within a radius of 30 cm of the magnet.

Limit values for occupational exposure (general and for limbs) are not exceeded.



**NOTICE**

Goudsmit Magnetics offers measurement inspection to measure the safe clearances of the in-built device on site in order to determine whether they deviate from the values specified above.

---



## 4 Specifications

### 4.1 Range of application

The device is suitable for many industrial applications where powders are transported in free fall or with slight overpressure of up to 1 bar. The design and grit-blasted, water-blasted or polished finish are intended for use in applications without risk of bacterial growth.

### 4.2 Description of function

The device filters fine ferromagnetic contaminants of 30 µm and larger – such as stainless steel wear particles – from powder flows. The product must not contain any ferromagnetic particles large or heavy enough to cause damage to the magnetic bars. Maximum particle size is 10 mm.

- If necessary, place a strainer before the product inlet of the device in your installation.

### 4.3 Flow rate

The recommended flow rate of the product material is 1 m/s. Maximum recommended flow rate is 2 m/s. A higher flow rate reduces separation efficiency, and therefore fewer ferromagnetic particles will be filtered from the product material.

### 4.4 Use in food product flows

The device is supplied as a stainless steel model as standard, with a 3 µm ceramic-blasted finish. This is suitable for normal food contact applications. All contact materials are compliant with EU regulation EC1935/2004. Higher-quality finishes are available for applications with more stringent requirements.

### 4.5 Temperatures

The devices are suitable for the following ambient and product temperatures:

Magnet quality used	Max. ambient temp.	Max. ambient temp. (ATEX)	Max. product temp.	Max. product temp. (ATEX)
GSN-42SH	-20 - 60°C	-20 - 60°C	100°C	100°C

The magnetic material must be protected against higher temperatures than those specified on the data sheet as the magnet will permanently lose magnetic force if exposed to higher temperatures.

### 4.6 Free space

The freely available space around the pipe magnet should be about 1 metre for maintenance and cleaning work.

### 4.7 Aansluitspanning

Aansluitspanning voor de deursensor of detectiesensor is 24 V<sub>DC</sub>.

### 4.8 ATEX (if applicable)

The mechanical composition of the standard device is free from its own sources of ignition and thus falls outside the scope of the ATEX Directive 2014/34/EU. The full explanation is provided in the ATEX exclusion declaration.

## 5 Product information

### 5.1 Construction

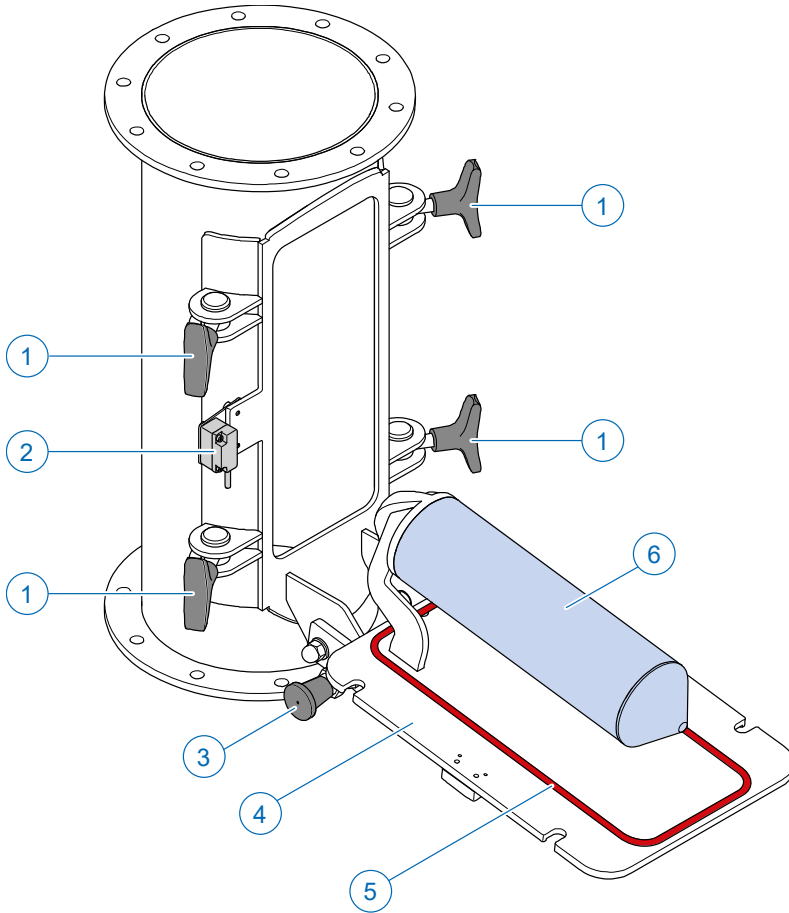

- |                        |                  |                   |
|------------------------|------------------|-------------------|
| [1] Toggle             | [3] Lock         | [5] Seal / Gasket |
| [2] Door safety switch | [4] Hatch / Door | [6] Magnetic bar  |

### 5.2 Scope of delivery

Check the shipment immediately upon delivery for:

- Possible damage and/or shortcomings as a consequence of transport. In the event of damage, ask the carrier for a transport damage report.
- Completeness.



#### NOTICE

In the event of damage or incorrect shipment, contact Goudsmit Magnetics immediately. The contact details are provided on the title page of this manual.

### 5.3 Identificatieplaat

The following identification data are shown on the device. The identification data are very important for maintenance of the device.

Always keep the identification data clean and legible. Always provide the article and order numbers when ordering spare parts, requesting service or reporting a malfunction.

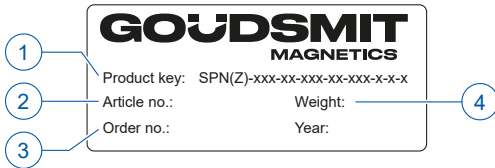

- |     |                |     |              |
|-----|----------------|-----|--------------|
| [1] | Product key    | [3] | Order number |
| [2] | Article number | [4] | Weight       |

### 5.4 Service life

Depending on operating conditions, a lifetime of 5 - 15 years is expected for the housing and magnet unit, and 2 - 5 years for the extractor.

### 5.5 Pressure test

All devices with a coupling or flange undergo a pressure test before delivery.

If the device has passed the pressure test, a test number [3] is shown on the identification plate.

See the data sheet for the prescribed pressure test.



#### NOTICE

- Devices with only welding ends do not undergo a pressure test.

### 5.6 Door sensor

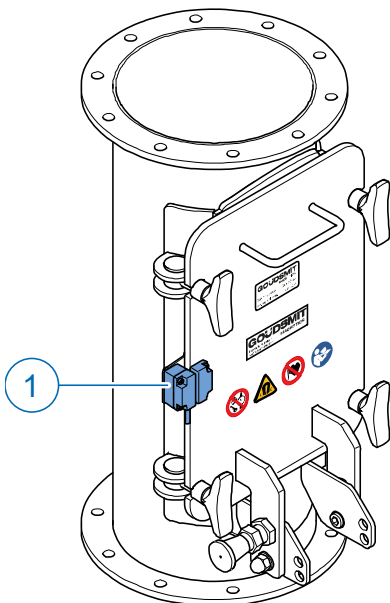

By default, the device is equipped with a door sensor [1] that detects when the door is in the open or closed position.

Because this sensor is used for detection, rather than a safety-related function, it is not necessary to connect it to a special safety relay for contactless sensors, which additionally feature current limitation and short-circuit detection.

In this way it can be ensured that the product flow is stopped when the door is unlocked. This prevents unnecessary loss of product material and its contamination.

### **5.6.1 Door switch**

The door switch acts as a safety switch and can be supplied in two versions:

- 1 As soon as the door is opened in operation, the motor immediately stops running (standard).
- 2 The door is electrically locked and can only be unlocked by a signal from the controller.

## 6 Transport and installation

### 6.1 Transport



#### WARNING

##### Note

The device permanently emits a magnetic force.

Observe the safety instructions for transport in the Safety risks [▶ 6] section.



#### WARNING

##### Note

- ▶ Lift the device by lifting eyes. Keep in mind the centre of gravity.
- ▶ **Crushing risk:** do not place your hands inside the crate during lifting. Maintain a distance of at least one metre.
- ▶ During transport, make sure the area around the device is clear.
- ▶ During transport, avoid all impact in order to prevent damage, especially to the magnetic bars.

The device is delivered in a crate. Fit at least two lifting eyes [1] (not supplied) to the flange.

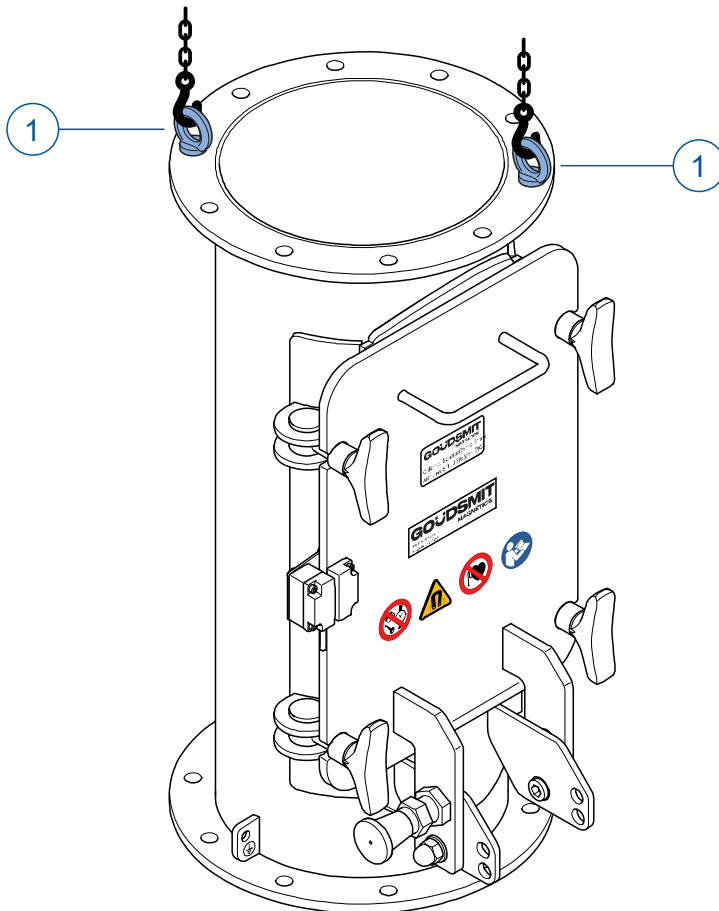

Lift the device out of the crate evenly. Use a hoisting unit that supports the device.

## 6.2 Installation



### NOTICE

Take the following precautions:

- ▶ Work safely, provide ample work space and use dependable scaffolding, ladders and other tools so the device can be installed without any risks.
- ▶ The device permanently emits a magnetic force. See the Safety risks [▶ 6] section for the precautions that must be taken when working on the device.
- ▶ Only qualified personnel should work on the device.
- ▶ Ensure that there is sufficient clearance around the installation to install the device in the installation/structure and for operation, inspection and maintenance work to be carried out.
- ▶ Ensure that no external vibration is transferred to the device, as this can cause permanent loss of magnetic force.
- ▶ Only non-magnetic structural parts are permitted within the range of the magnetic field in order to prevent a negative impact on the removal of ferrous particles. In simple terms, the magnetic field may not be 'short circuited'.
- ▶ Only use lifting/hoisting tools that are in good condition, and do not exceed the lifting capacity of the tools.
- ▶ The supply and discharge channels and structure must be sufficiently strong to bear the weight of the device with the captured ferrous particles.
- ▶ When installing the device, ensure that the free-fall height of your product is a **maximum of 0.4 metres**. A higher free-fall height will increase the speed of the product, resulting in poorer separation.



### CAUTION

#### Risk of injury from edges and sharp corners

- ▶ Take extremely care when carrying out work near sharp edges and pointed corners.
- ▶ Wear protective gloves if you are unsure.

- Install the device free of mechanical stress and at the correct working height in your product chute for the operating personnel. Mechanical stress on the device can cause deformation and other problems.
- Follow the installation instructions in accordance with the relevant standards for the flanges to install the device in your installation. Misalignment or loose mounting can cause leakage.
- Only install the device in the vertical orientation (see illustration). In reversed orientation, bear in mind when opening the door that residue will run out during maintenance work.

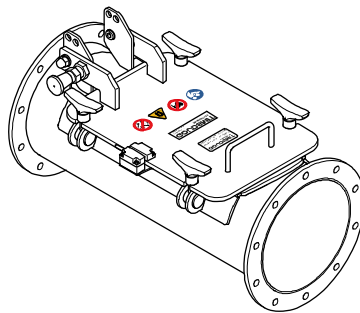
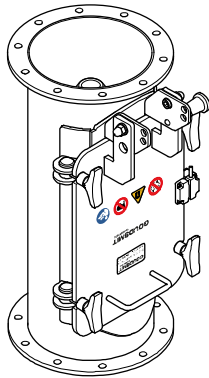
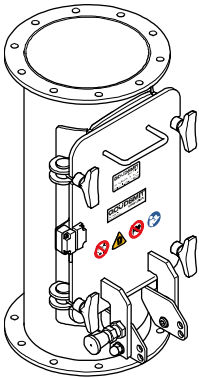

- Use a suitable lifting/hoisting arrangement that supports the weight of the device.
- Remove the lifting/hoisting arrangement after installation is complete.
- Clean the device thoroughly before commissioning.

### 6.3 Preventing electrostatic discharges (earthing)

To prevent electrostatic discharge, a provision must be made to prevent potential differences between the installation and the device. This can be done by installing a connection cable [1] to the installation. The electrical resistance must be less than 25  $\Omega$ .

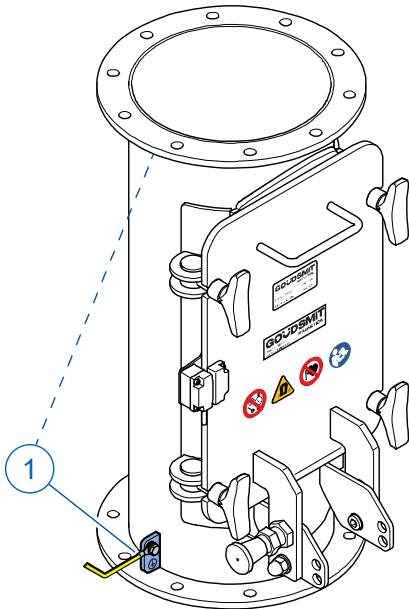

## 7 Working principle

### 7.1 General

The magnetic unit consists of a very strong neodymium magnetic bar with multiple magnetic poles located in the middle of the product flow. The product contaminated with ferromagnetic particles passes the magnetic bar as it flows through the device.

The magnet attracts passing ferromagnetic contaminants. The captured particles stick to the magnet, while the purified product flows on.

### 7.2 Cleaning process – disposal of ferromagnetic particles

When cleaning the device, wear the requisite protective clothing, such as overalls, gloves, goggles and safety shoes.



#### Cleaning process – removal of ferromagnetic particles

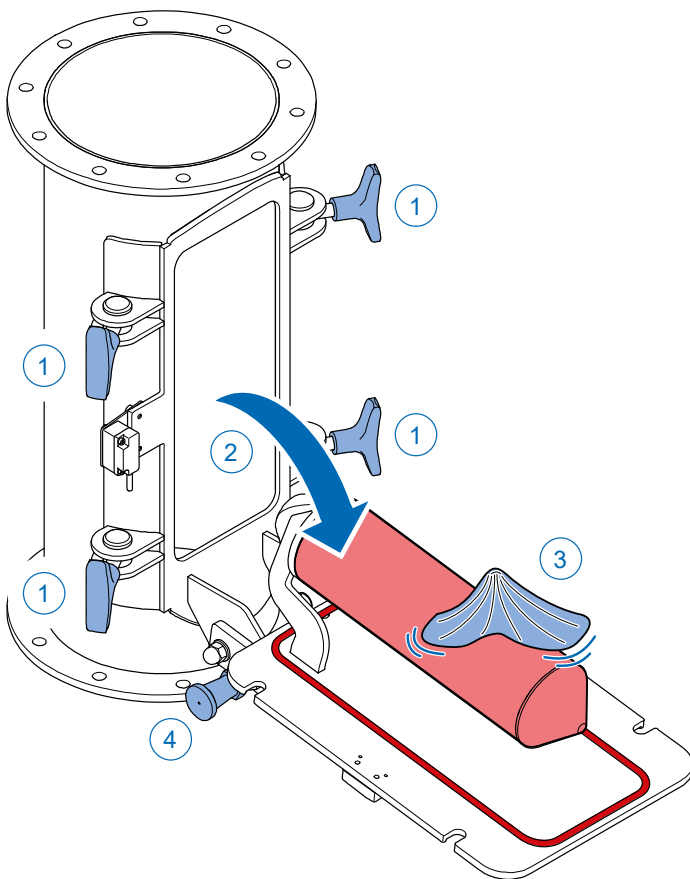

To clean, proceed as follows:

- Stop the product flow.
- Unlatch the door using the toggles [1].
- Swing open the door with the magnetic bar [2], until it engages in the latch.
- Clean all parts with a soft, clean cloth [3] and brush and – if necessary – with a suitable cleaning agent.



- Collect the ferromagnetic particles that now fall off the extractor tube and dispose of them.
- Release the door [4].
- Swing the door with magnetic bar back against the housing.
- Secure the door with the toggles [1].
- Production can be safely resumed.

## 8 Maintenance and inspection

### 8.1 General guidelines



#### WARNING

##### Risk of crushing

In view of the large magnetic forces, replacing the internal magnet components is extremely dangerous as they are difficult to handle. Replacement may ONLY be carried out by appropriately qualified personnel or (ideally) by Goudsmit Magnetics technicians.

If the replacement is carried out by unqualified personnel, the warranty will be void.

Goudsmit Magnetics cannot be held liable for any consequential damage to people and/or materials if this prohibition is ignored.



#### CAUTION

##### Risk of burns from hot flow product

Contact with hot flow product may cause burns.

- ▶ Always wear protective work clothing and safety gloves when carrying out work near hot liquids.
- ▶ Make sure the flow product has cooled down to ambient temperature before carrying out any work.



#### WARNING

##### Caution

The product flow must be stopped when work is being carried out on the device.

Exercise caution with tools. The magnetic force is permanent.

Magnetic systems do not only attract ferromagnetic particles, but a small proportion of your product will also continue to 'adhere' to the magnet. Remove all captured particles from the magnet at regular intervals. A clean magnet is considerably more effective.

- Always inform operating personnel of scheduled inspections, maintenance, repairs and in the event of faults.
- Check regularly that all warning pictograms are still present in the correct locations on the device. If these are lost or damaged, replace them with new pictograms in the original locations immediately.
- Ensure that the device is externally clean. Remove dust, dirt and particles from the device as appropriate.

## 8.2 Frequency of maintenance



### NOTICE

Goudsmit Magnetica offers an annual maintenance inspection, including replacement of the seal(s) and an inspection report with certificate for the magnets.

Action	Daily	Monthly	6-monthly
Clean magnetic bar (for maximum performance) (► Reinigingsinstructies [► 16]).	min. 2x <sup>1)</sup>		
Check seal for wear and presence.	•		
Check the operation of the door sensor		•	
Measure flux density of magnetic bar (► Fluxdichtheidsmeting van de magneetstaaf [► 19]).		•	
Check magnetic bar for wear.		•	
Replace seal (► Replacing seal [► 20]).			•

<sup>1)</sup> The frequency of the cleaning process depends on the capacity of your product flow and the level of soiling.

## 8.3 Cleaning instructions

### Wet or dry cleaning

If the use of fluids is prohibited in your installation, use disinfectant cloths that are suitable for contact with the processed product, if necessary.

The frequency of cleaning is dependent on the degree of cleanliness required for the processed product. The frequency of cleaning must be increased in applications where sensitive food products are processed. Perform a hygiene risk assessment to determine the requirements in your situation.

### When used in food product flows

Cleaning and disinfectant methods and agents that are used for cleaning must be adapted to the specific type of soiling (carbohydrates, proteins, fats, etc.) and the degree of cleaning required for your application. The type of product that is processed thus determines to a large extent which combination of cleaning agents is suitable. Consult your cleaning agent supplier to select the correct cleaning agents for your specific situation.

Check with your cleaning agent supplier whether the products are suitable for the material of the chosen seals (silicone, NBR or Viton).

The device is made of stainless steel or 'food-grade stainless steel' 1.4301/SAE 304L and 1.4404/SAE 316L.

## 8.4 Flux density measurement of the magnetic bar

The magnetic bar must be measured at periodic intervals to check its magnetic flux density and to determine whether the magnetic force has decreased. Use a suitable gauss meter/tesla meter to measure the poles of the magnetic bar on the surface (the unit is tesla, gauss, kA/m or oersted).

Goudsmit Magnetica can perform magnet measurements on location, if desired. Proceed as follows:

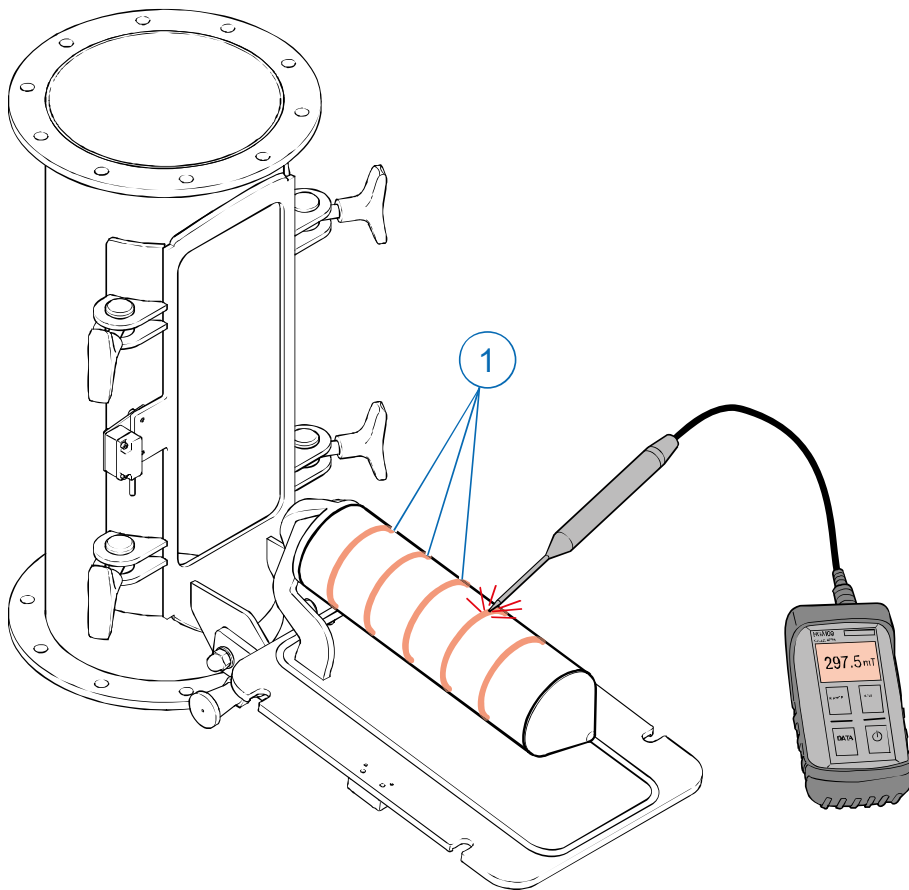

- Stop the product flow.
- Loosen the toggles.
- Swing the door with magnetic bar open until it drops into the latch.
- Clean the magnetic bar with a soft, clean cloth or brush and, if necessary, a suitable cleaning agent.
- Using the gauss meter/tesla meter, move along the poles [1] of the magnetic bar.

The measured values may fluctuate for various reasons, such as the position (angle) of the probe on the magnetic bar tube, the thickness of the probe and the reproducibility of the measurement.

- Record the highest measured value.
- Using the accompanying data sheet, check whether the measured value falls within the permitted value of the peak value.
- Release the door.
- Swing the door with magnetic bar back against the housing.
- Secure the door with the toggles.
- Production can be safely resumed.

## 8.5 Replacing seal

We recommend replacing the seal at least every six months or more frequently, depending on the level of wear. Proceed as follows:

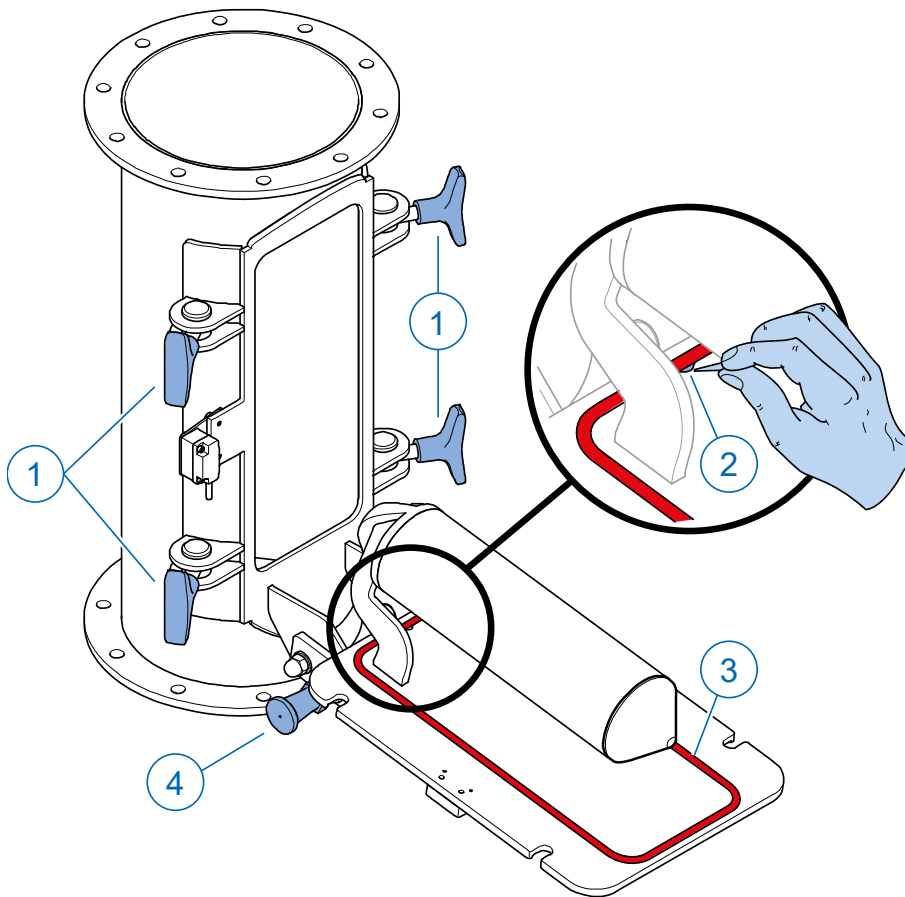

- Stop the product flow.
- Loosen the toggles [1].
- Swing the door with magnetic bar open until it drops into the latch.
- Remove the old seal from the door. In doing so, make use of the notch in the groove [2].
- Thoroughly clean the groove in which the seal was seated, and fit a new seal [3].
- Clean the magnetic bar with a soft, clean cloth or brush and, if necessary, a suitable cleaning agent.
- Release the door [4].
- Swing the door with magnetic bar back against the housing.
- Secure the door with the toggles [1].
- Production can be safely resumed.

If the seal wears out too quickly, e.g. due to excessive temperature or an excessively abrasive product, enquire about alternative seals.

## 9 Troubleshooting

### 9.1 Troubleshooting table

Use the following table to search for faults, determine the possible cause and find the remedy. In the event of a fault that is not in the table, contact Goudsmit Magnetics customer service.

Problem	Possible cause	Solution
The device does not separate ferromagnetic particles completely or at all.	The magnetic bar is overloaded with ferromagnetic particles.	<ul style="list-style-type: none"> <li>● Remove the captured particles from the magnetic bar (more frequently).</li> <li>● Use a permanent magnet to check whether the separated particles are ferromagnetic.</li> </ul>
	Particles that are not attracted are not sufficiently ferromagnetic.	<ul style="list-style-type: none"> <li>● Check the magnetic behaviour of the installed components around the magnet by holding a ferrous component close to the magnet. If there are parts that react to the magnet, replace them with non-magnetic parts, such as those made from stainless steel.</li> </ul>
Leakage of product material.	Seal is not seated properly in the groove.	<ul style="list-style-type: none"> <li>● Fit the seal in the groove properly.</li> </ul>
	Seal is worn out.	<ul style="list-style-type: none"> <li>● Replace the seal.</li> </ul>
Door safety switch does not detect.	Door not closed properly.	<ul style="list-style-type: none"> <li>● Check the switch and close the door properly.</li> </ul>

## 10 Service, storage and disassembly

### 10.1 Customer service

Have the following information to hand when contacting customer service:

- Data from the identification plate.
- Type and scope of the problem.
- Presumed cause.

### 10.2 Spare parts

The high quality of the products from Goudsmit Magnetics means that the magnet product is highly reliable in operation.

However, if a particular part needs to be replaced, you can order a new one by providing the type number listed on the identification plate or on the attached drawing(s) and/or the data sheet.

Spare parts are usually parts that are subject to wear. These include:

- seal
- magnetic bar

How quickly the seal wears will depend on your product and how abrasive it is, as well as the capacity of your product flow. See the data sheet for the precise specifications. Please get in touch with us for information on the availability of the seal.

- When ordering, state the article and order numbers that appear on the identification plate.
- For further information, please contact us by +31 (040) 22 13 283 or consult our website.

### 10.3 Storage and disposal

#### Storage

If you do not intend to use the magnet product for an extended period of time, we recommend placing the device in a dry, safe place, and applying preservative to the vulnerable parts, if necessary.

#### Disposal/recycling

When dismantling and/or scrapping the magnet product, keep in mind the materials from which the individual parts are made (magnets, iron, aluminium, stainless steel, etc.). This should ideally be done by a specialized company. Always observe the local regulations and standards pertaining to industrial waste disposal.

Inform those disposing of the magnet material of the hazards of magnetism. To this end, see also the Safety risks [► 6] section.

