

REV	DATE	BY	DESCRIPTION
-	12-12-2013	BS	ORIGINAL DRAWING
A	12-2-2020	JVe	MODEL UPDATED TO LATEST VERSION

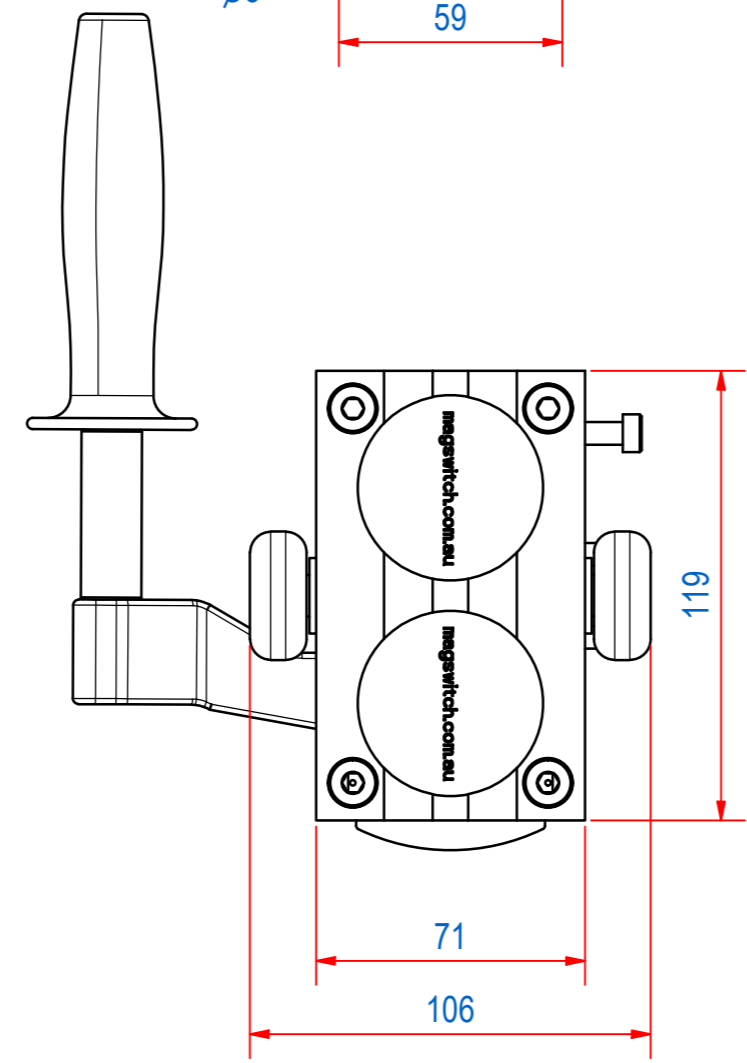

RAW MAT.	1	Quantity	Material Number	Material Description	Length (mm)	Width (mm)
Symbol	Sheet:	A2	Extra info:	General tolerance:	ISO 2768- mK	
Drawn:	Weight (kg):	4,3		Drawn according:	ISO268; ISO1101; ISO2553	
Date:	11-12-2013			Status:	Standard	
Spare part:	False	Source:		Customer reference number:		
Quick search:	MS050X2			Document number:	MS-8100360	Doc.Rev: A
Description:	HMS-MLAY600x2 LIFT MAGNET-50MM				Part number:	MS-8100360
					Rev:	A

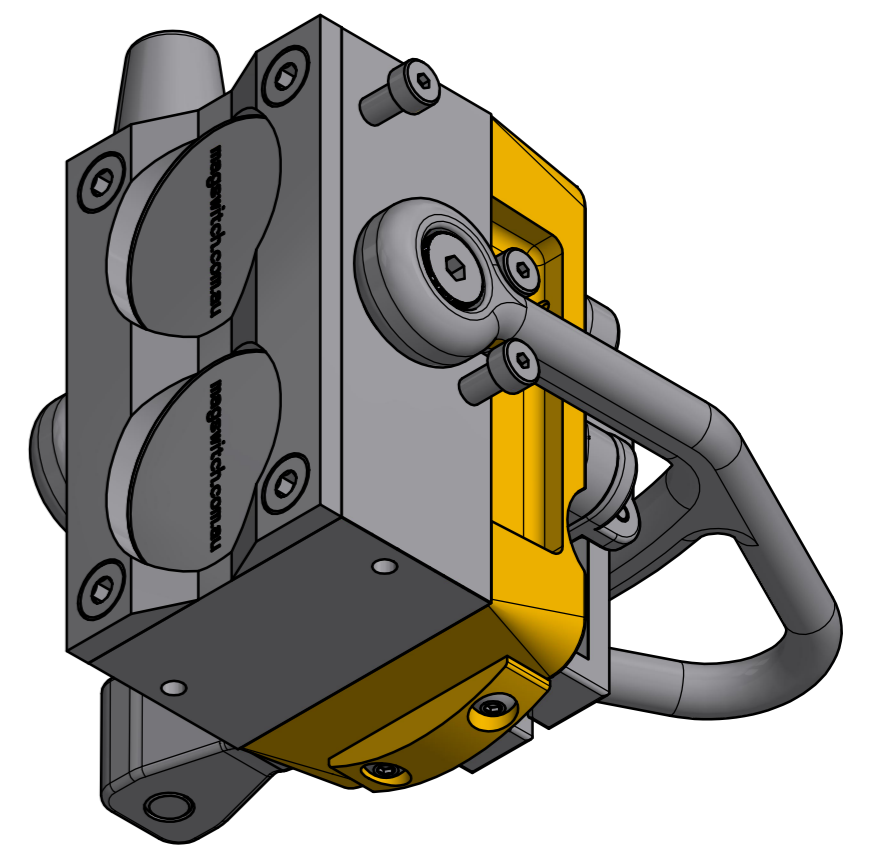
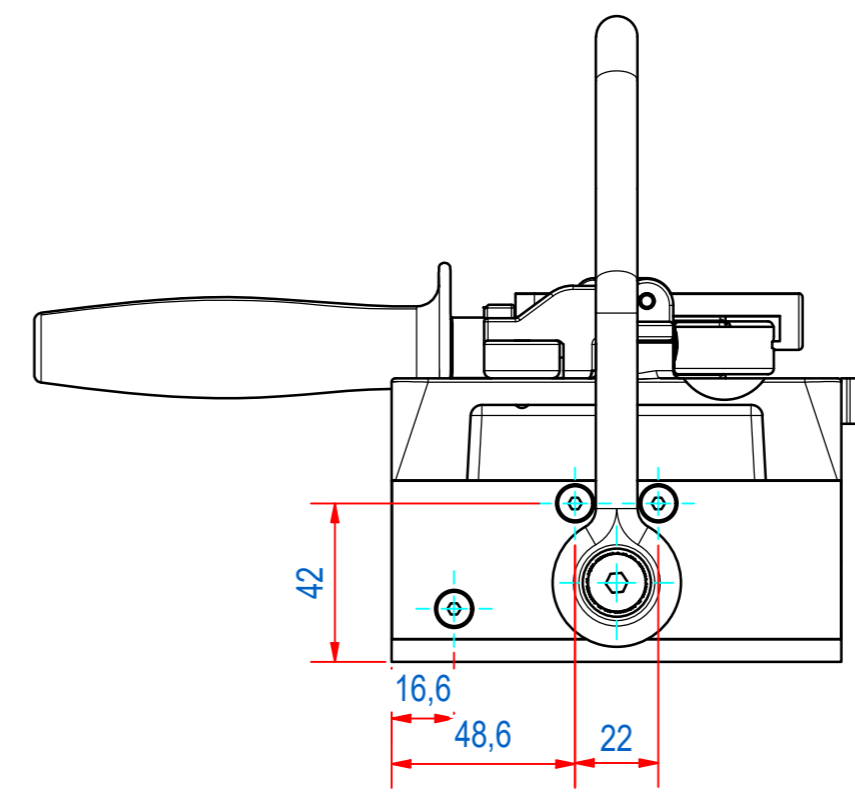
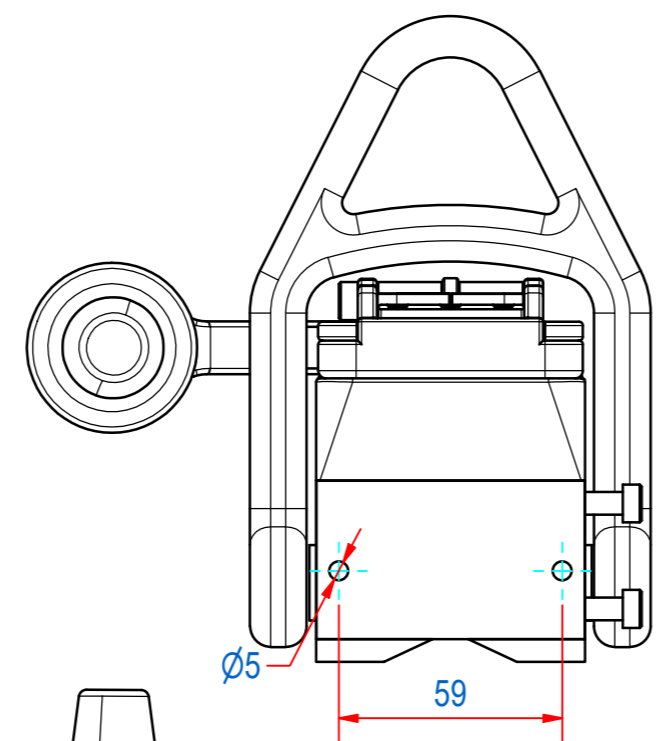
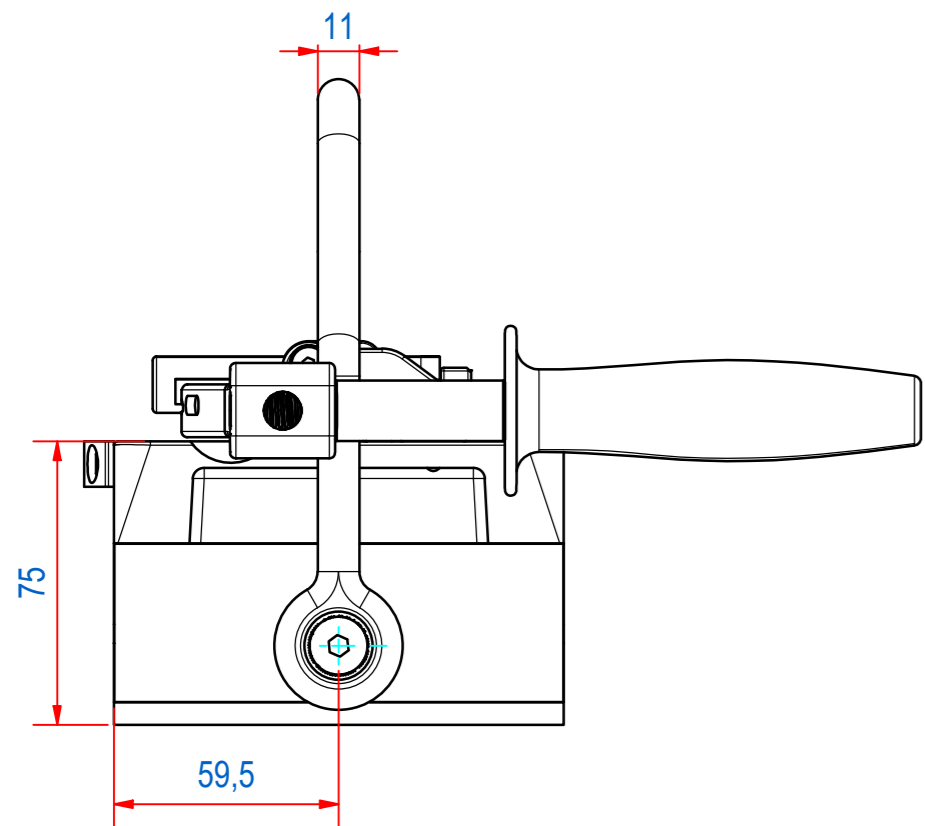
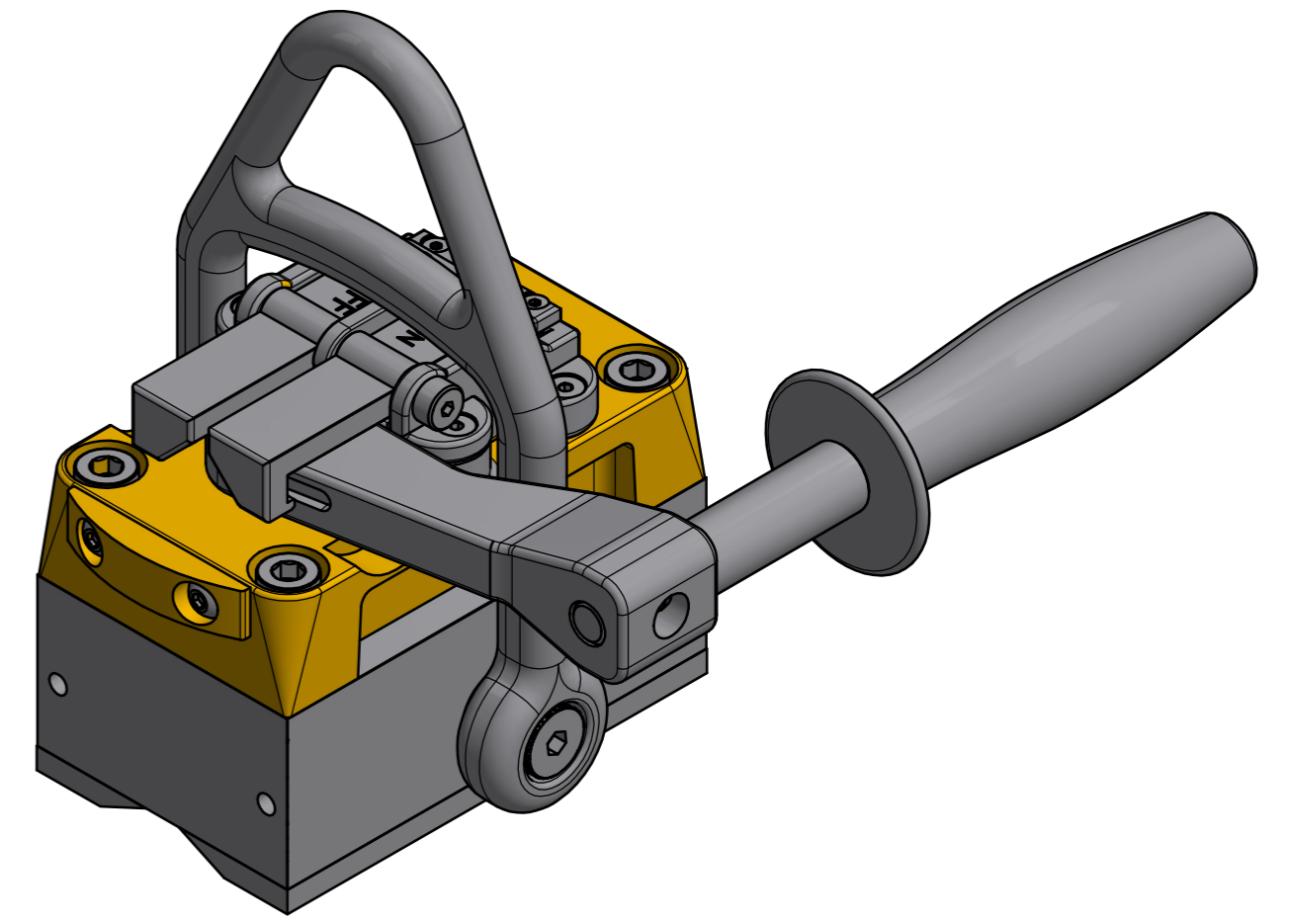
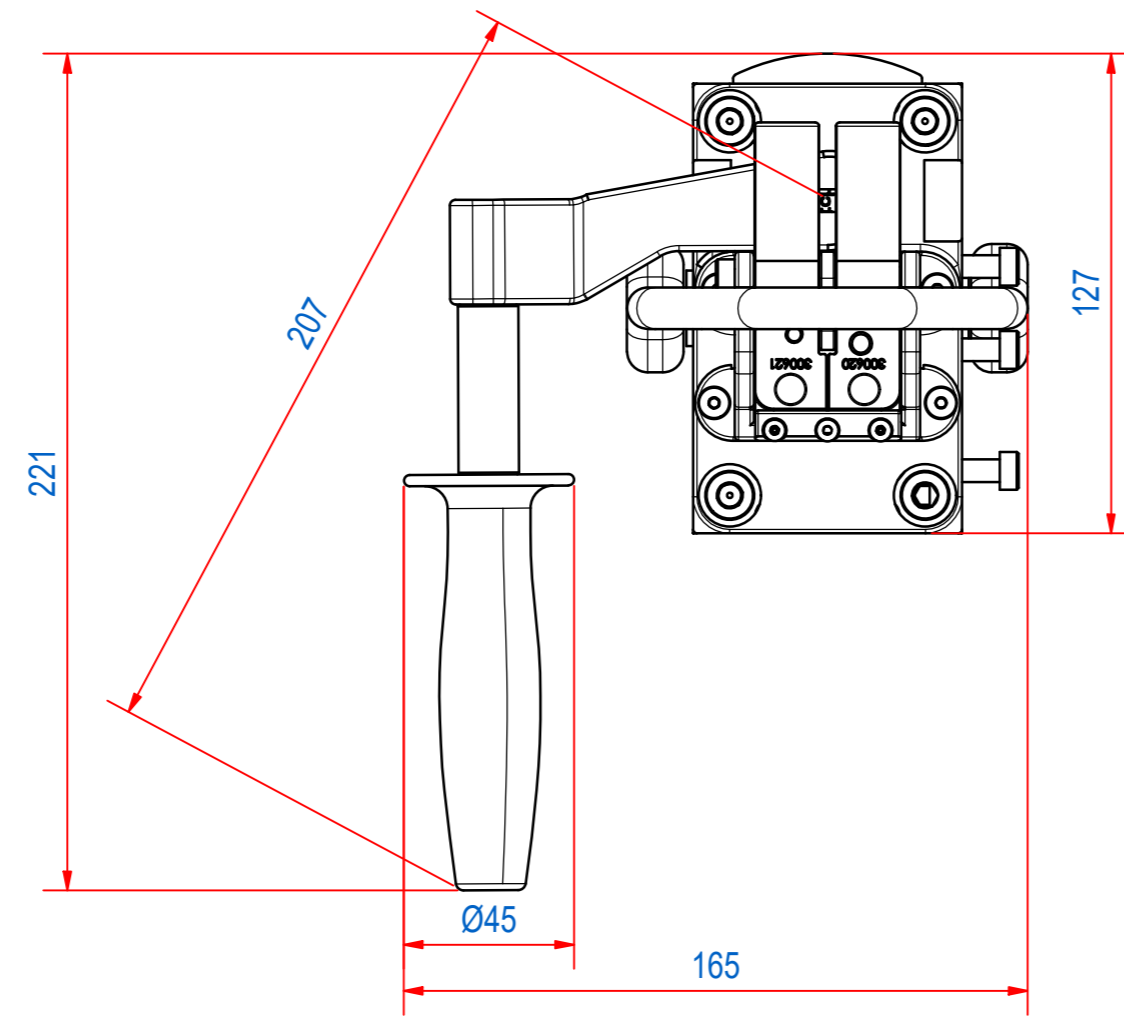

© All rights reserved. Reproduction is not permitted without written permission of GOUDSMIT Magnetic Systems BV