

REV	DATE	BY	DESCRIPTION
-	12-12-2013	BS	ORIGINAL DRAWING
A	12-2-2020	JVe	MODEL UPDATED TO LATEST VERSION

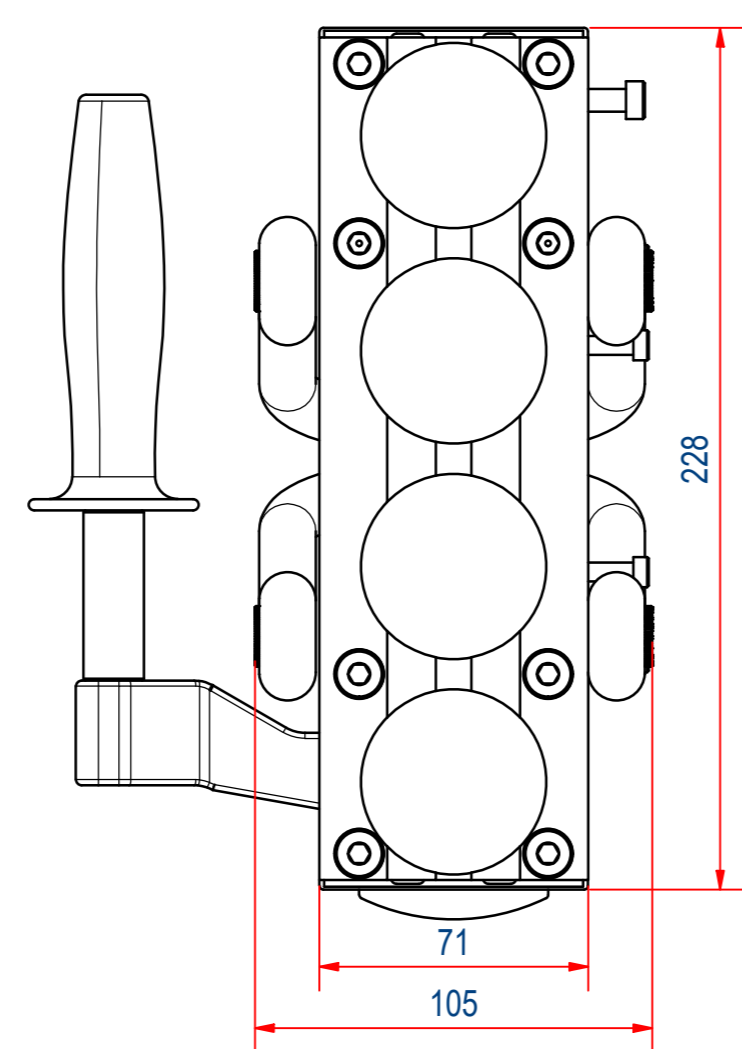
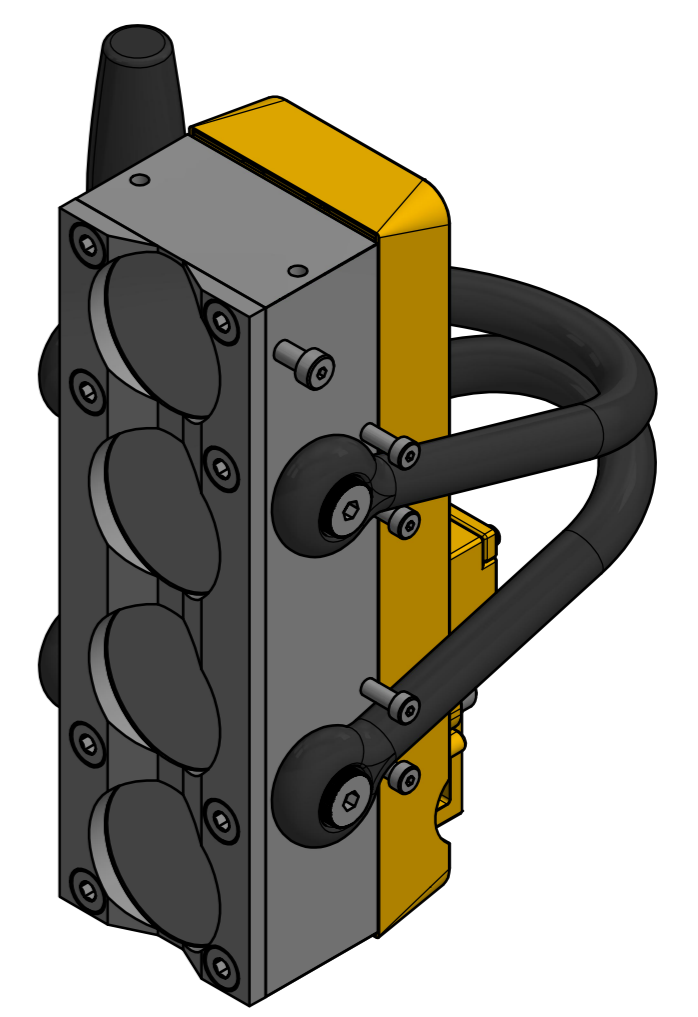
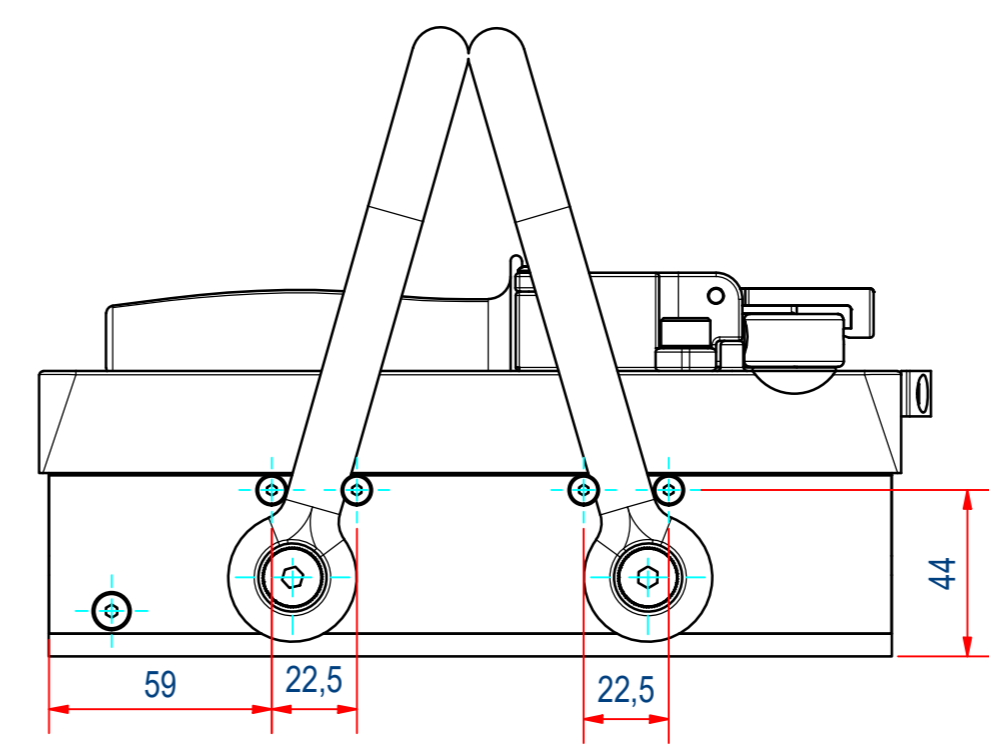
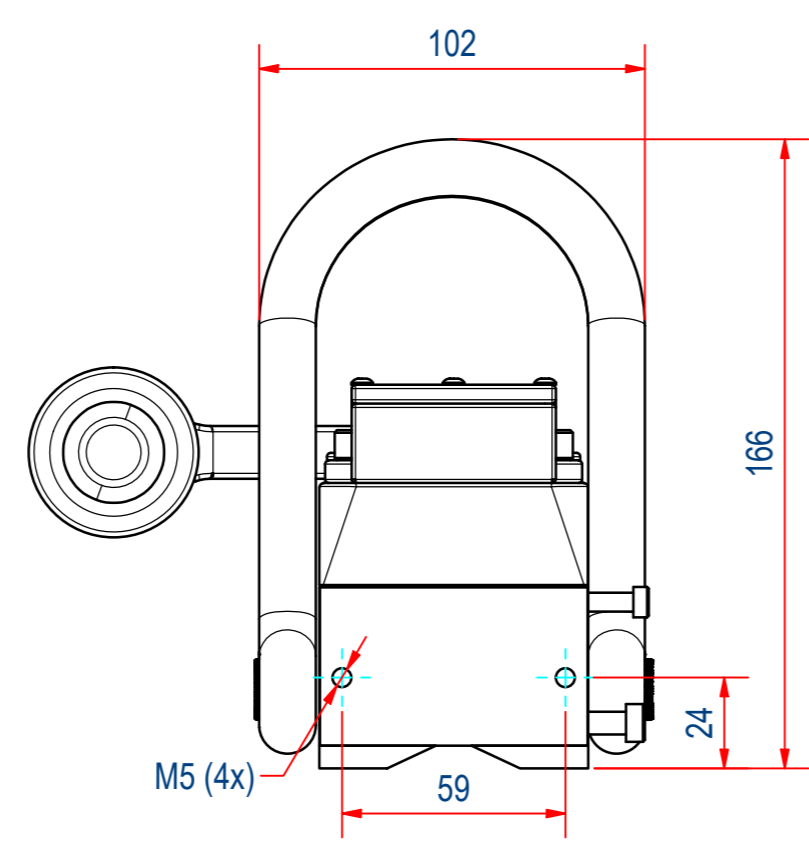
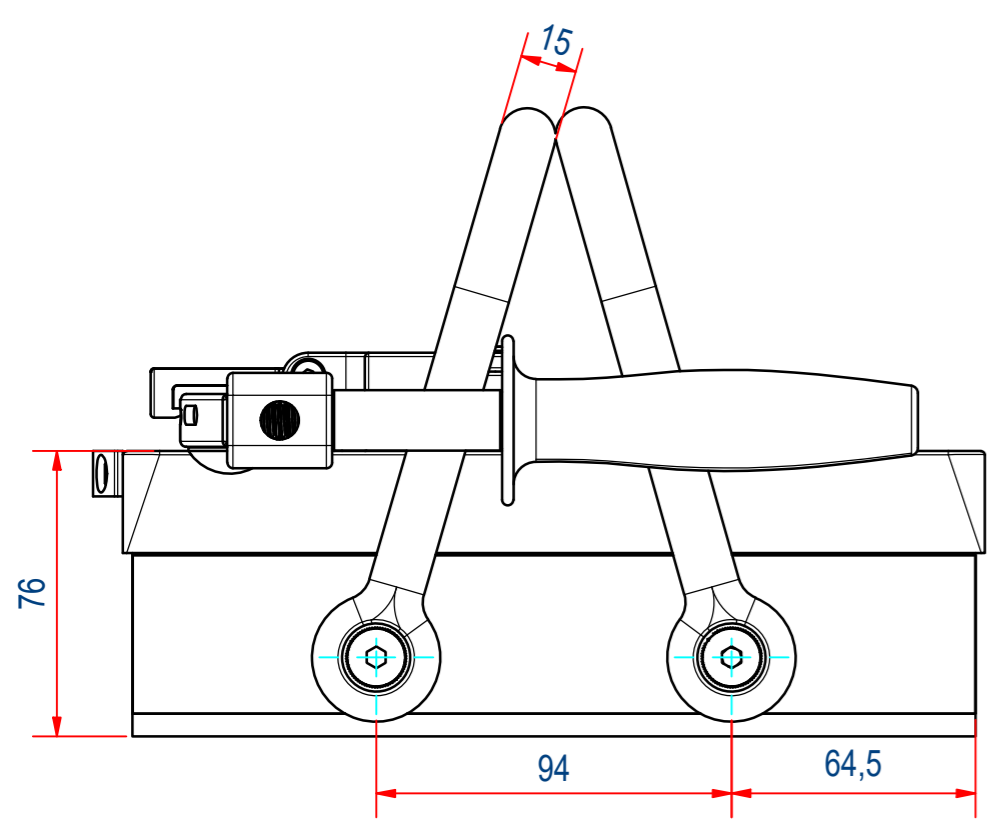
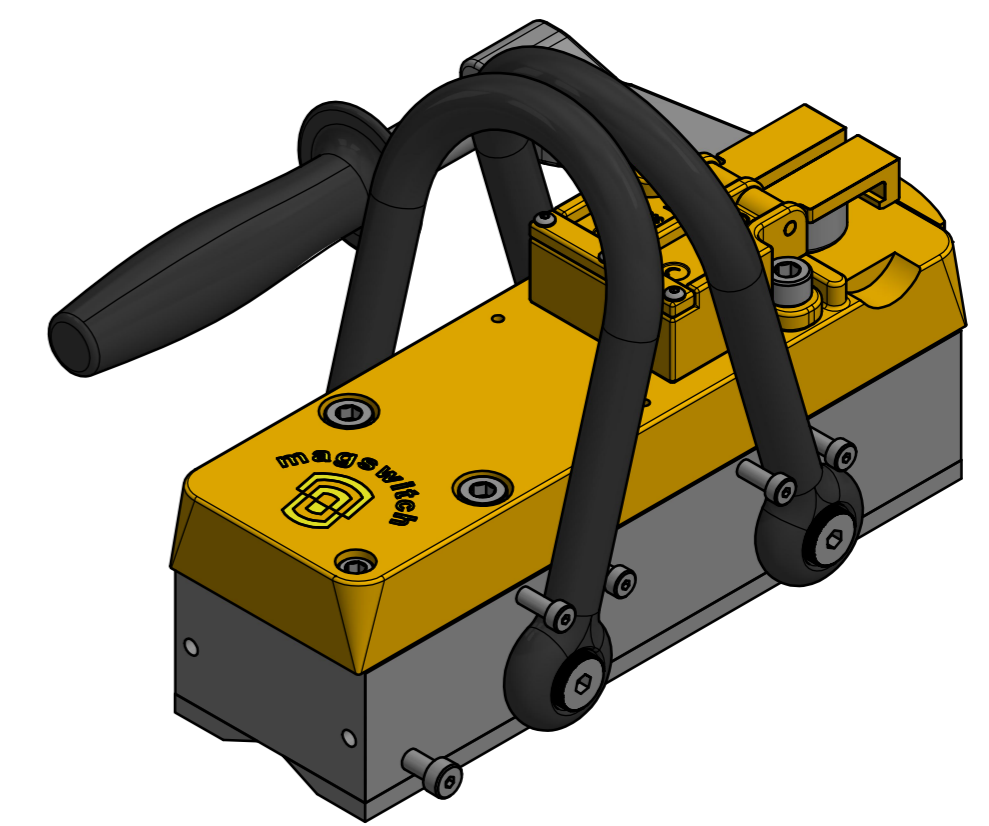
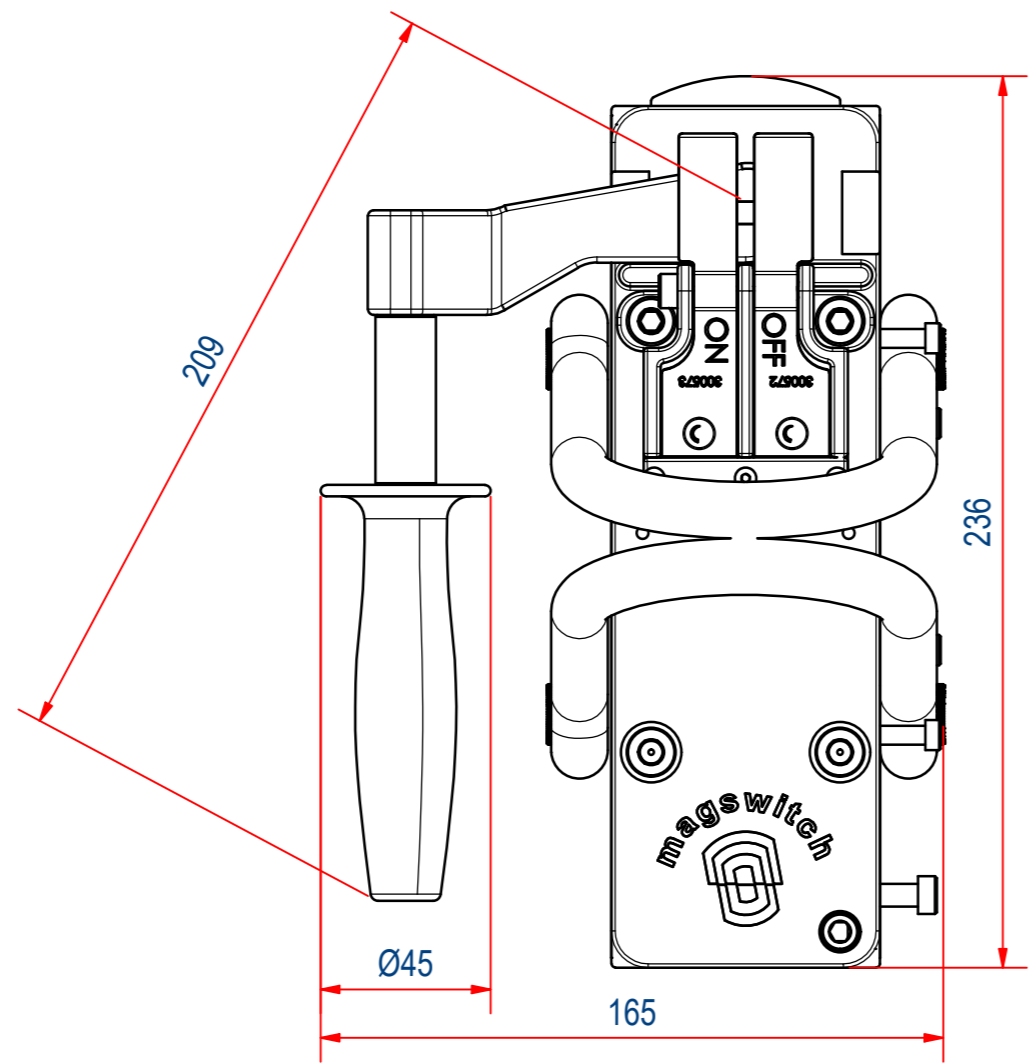

RAW MAT.	1	Quantity	Material Number	Material Description	Length (mm)	Width (mm)
⊕	Sheet:	A2	Extra info:	General tolerance:	ISO 2768- mK	
Drawn:	AVD	Weight (kg):	8,2	Drawn according:	ISO268; ISO1101; ISO2553	
Date:	5-7-2012	Status:	Standard	Customer reference number:		
Spare part:	False	Source:		Document number:	MS-8100364	Doc.Rev: A
Quick search:	MS050X4			Part number:	MS-8100364	Rev: A
Description:	HMS-MLAY600x4 LIFT MAGNET-50MM					