

REV	DATE	BY	DESCRIPTION
-	12-12-2013	BS	ORIGINAL DRAWING
A	12-2-2020	JVe	MODEL UPDATED TO LATEST VERSION

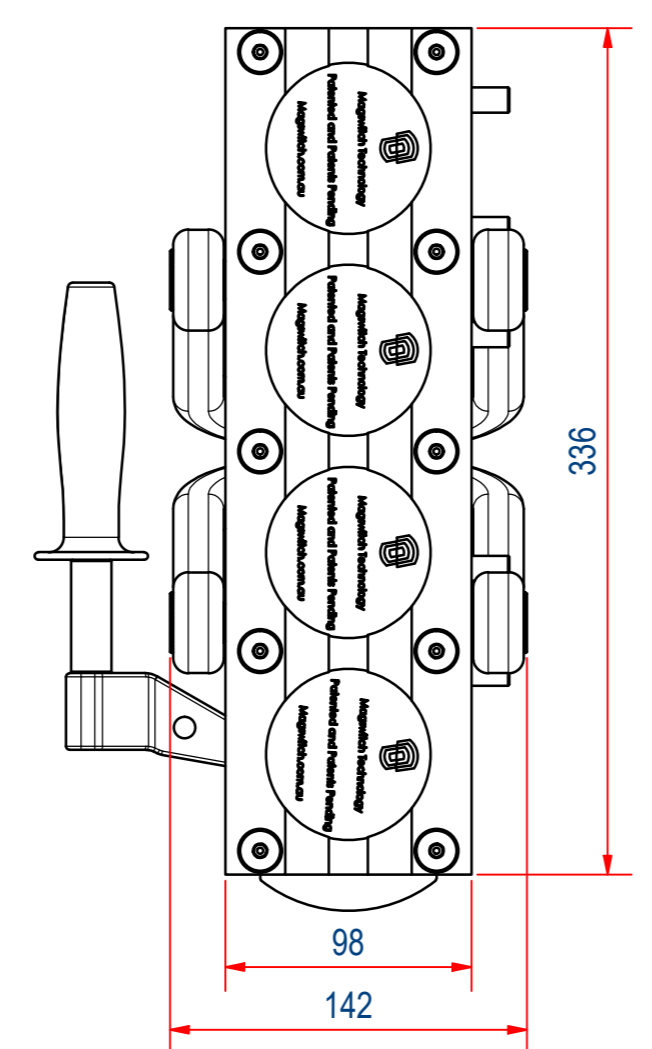
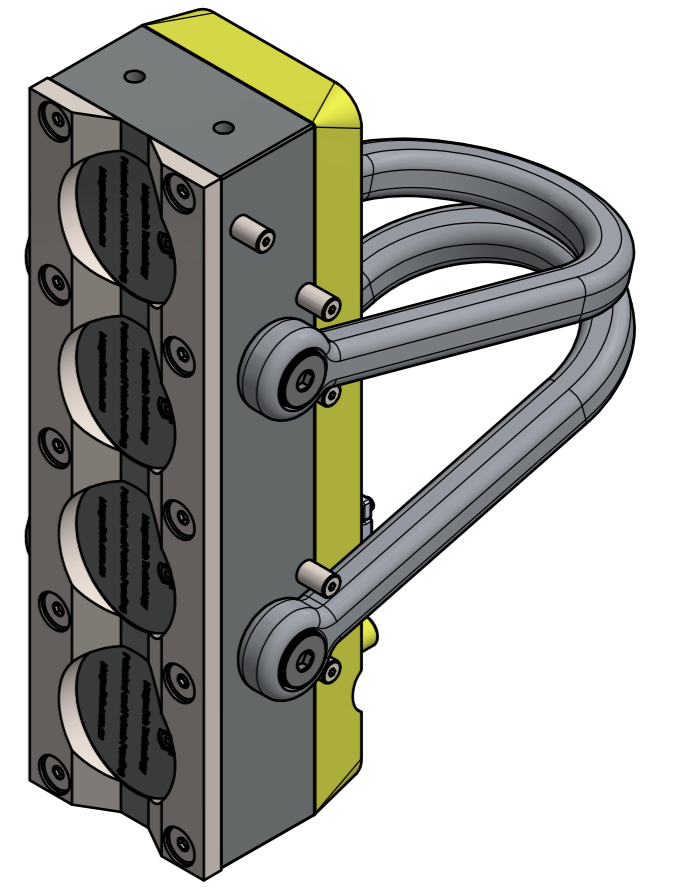
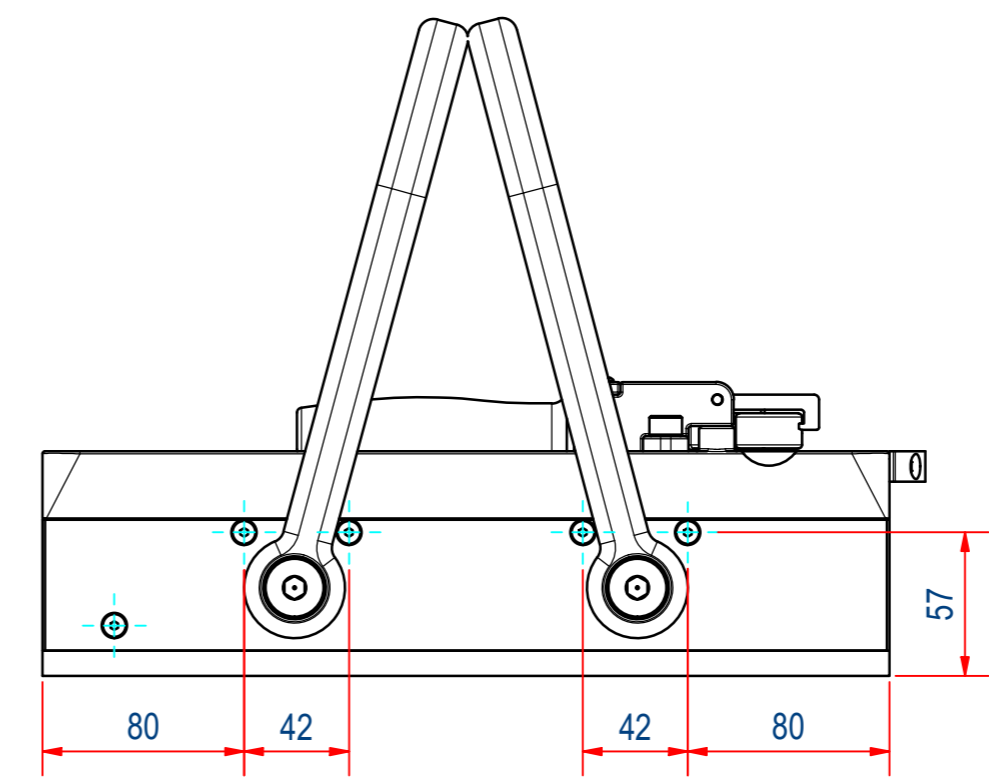
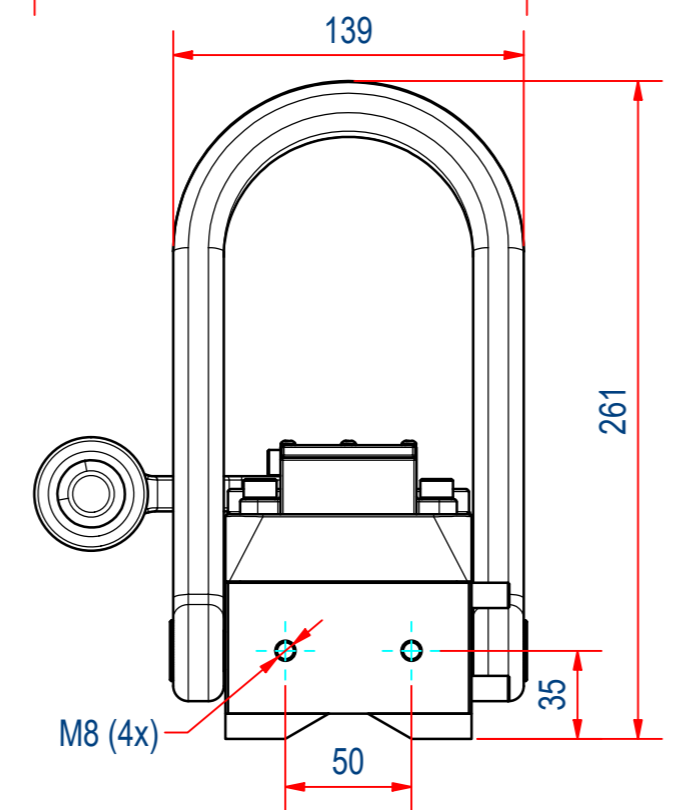
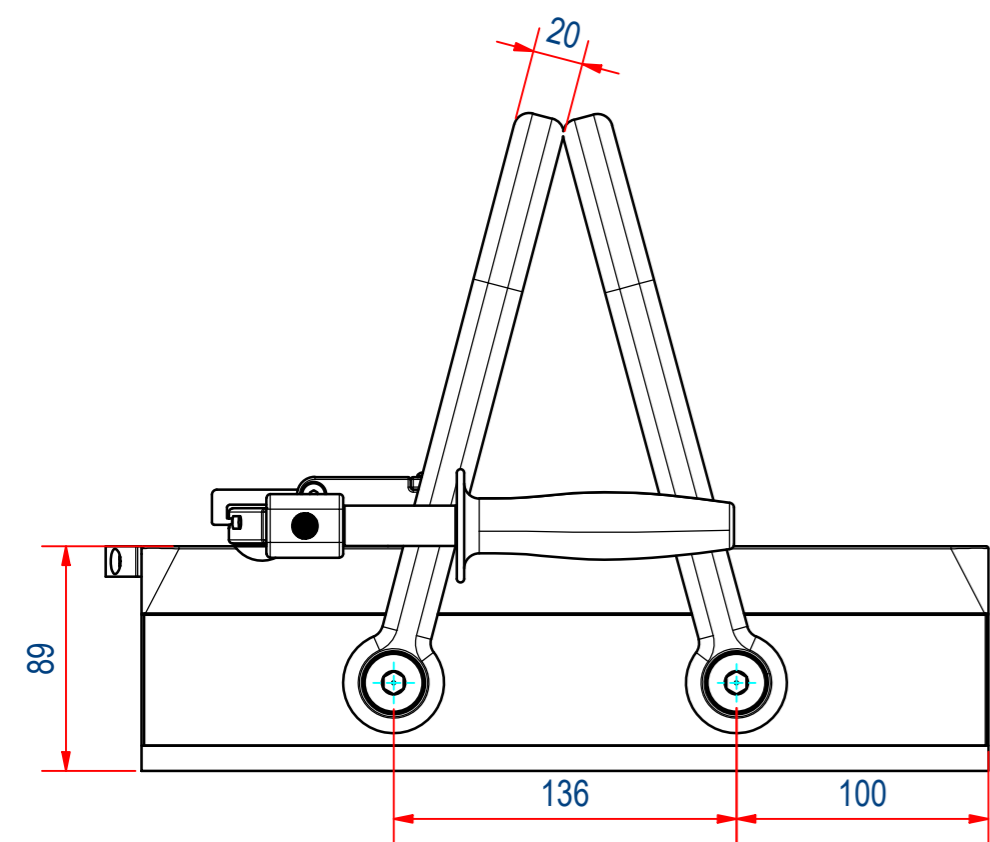
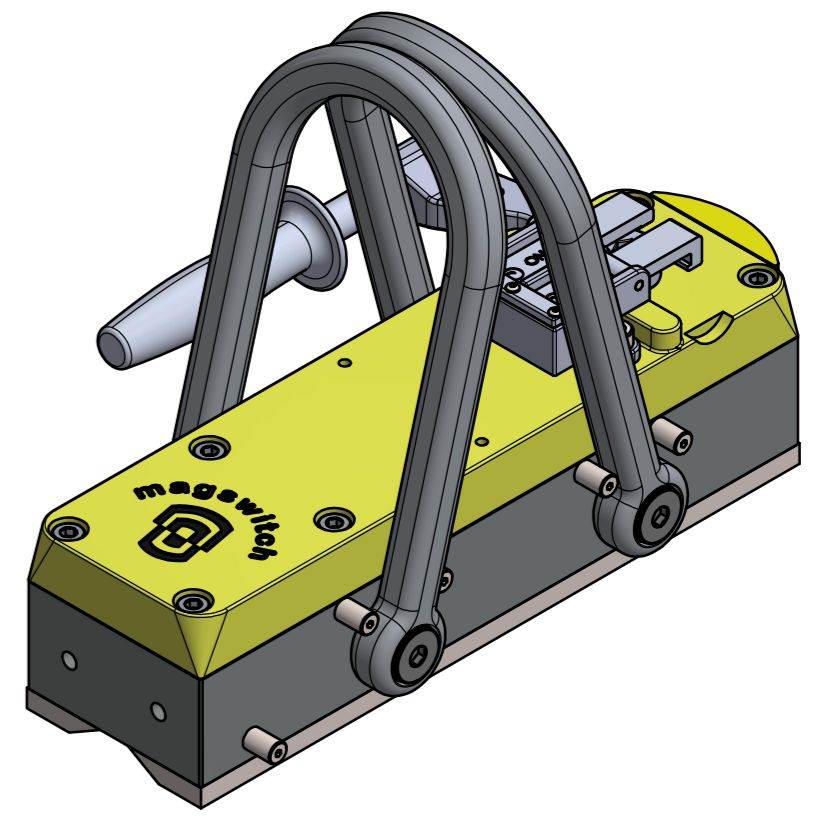
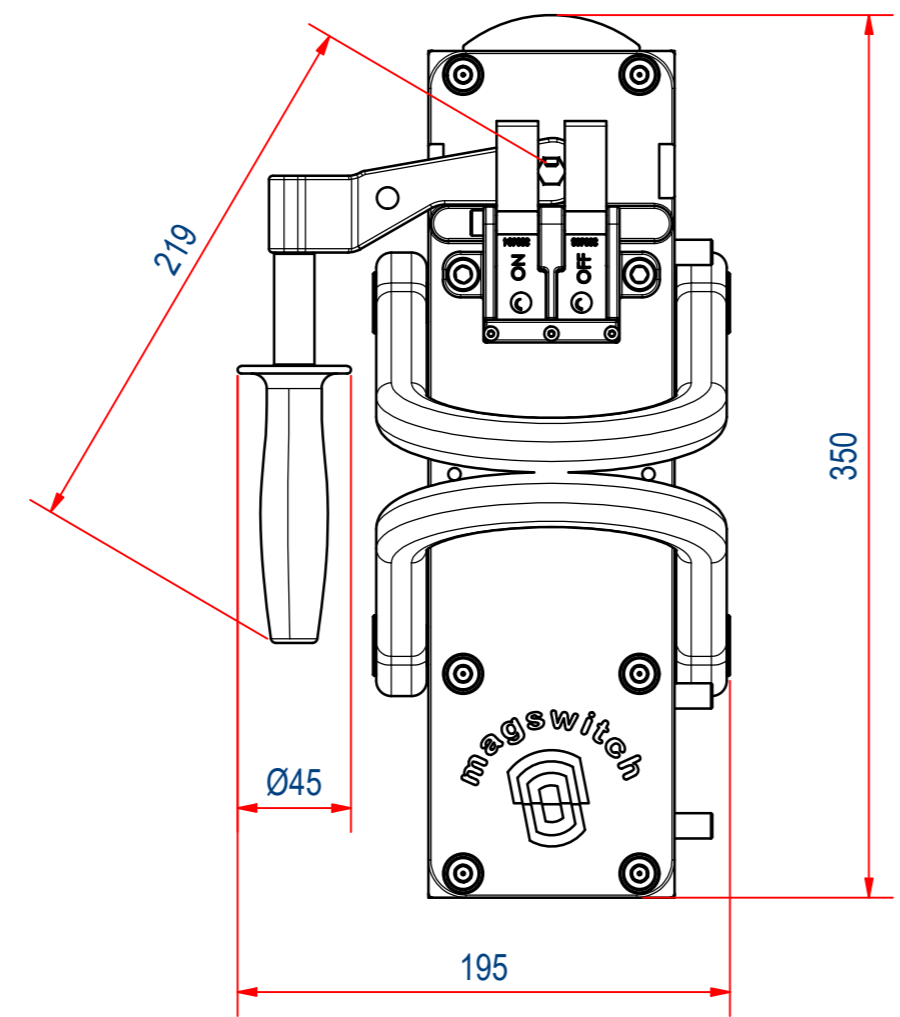

RAW MAT.	1	Quantity	Material Number	Material Description	Length (mm)	Width (mm)
Drawn:	AVD	Sheet:	A2	Extra info:	General tolerance: ISO 2768 - mK	
Date:	5-7-2012	Weight (kg):	20		Drawn according: ISO268; ISO1101; ISO2553	
Spare part:	False	Source:			Status: Standard	
Quick search:	MS070X4	Description:		HMS-MLAY1000x4 LIFT MAGNET-70	Document number:	MS-8100418
				Part number:		MS-8100418
				Doc.Rev:		A
				Rev:		A