

3	2	1		
DOC.NR.	REV	DATE	BY	DESCRIPTION
MS-81401167	-	20-2-2020	JVe	ORIGINAL DRAWING

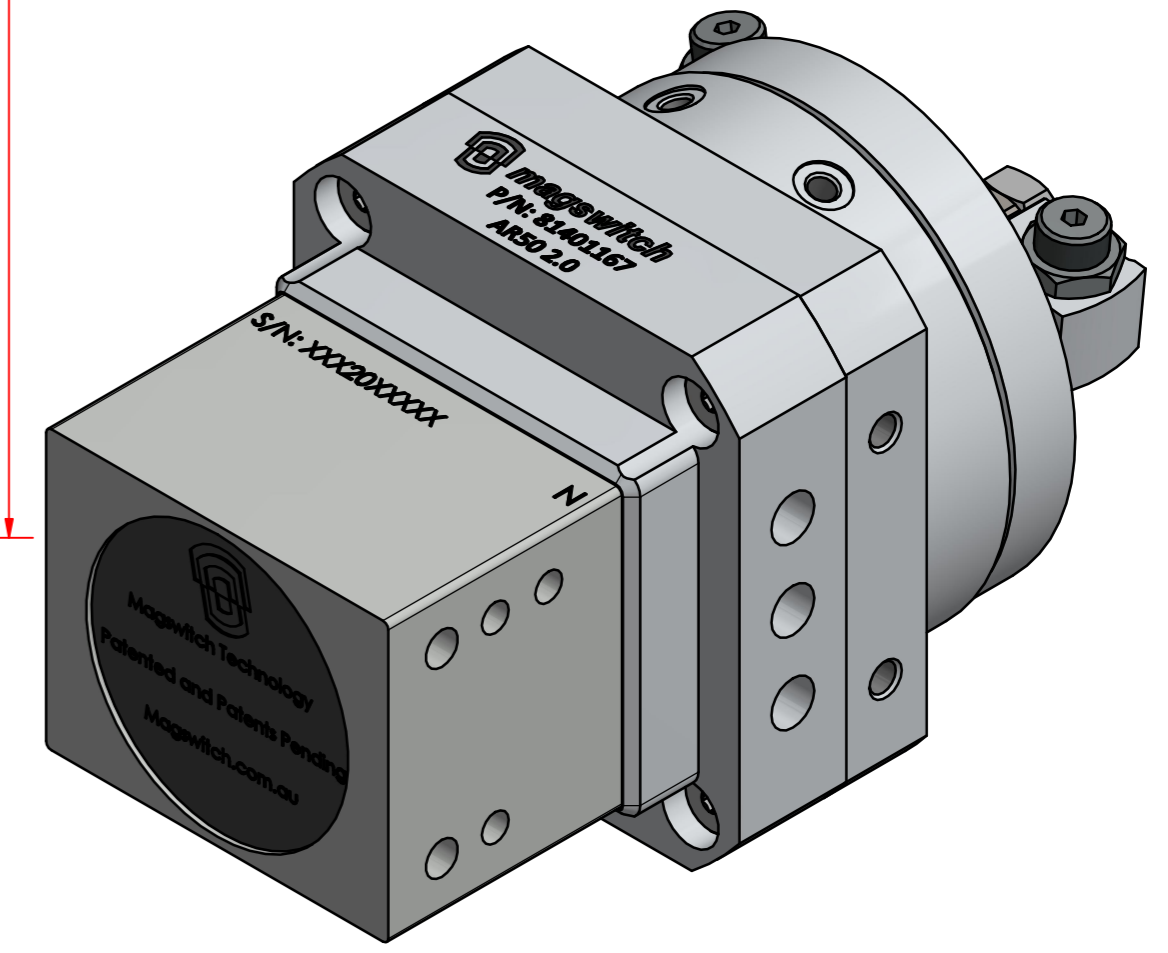
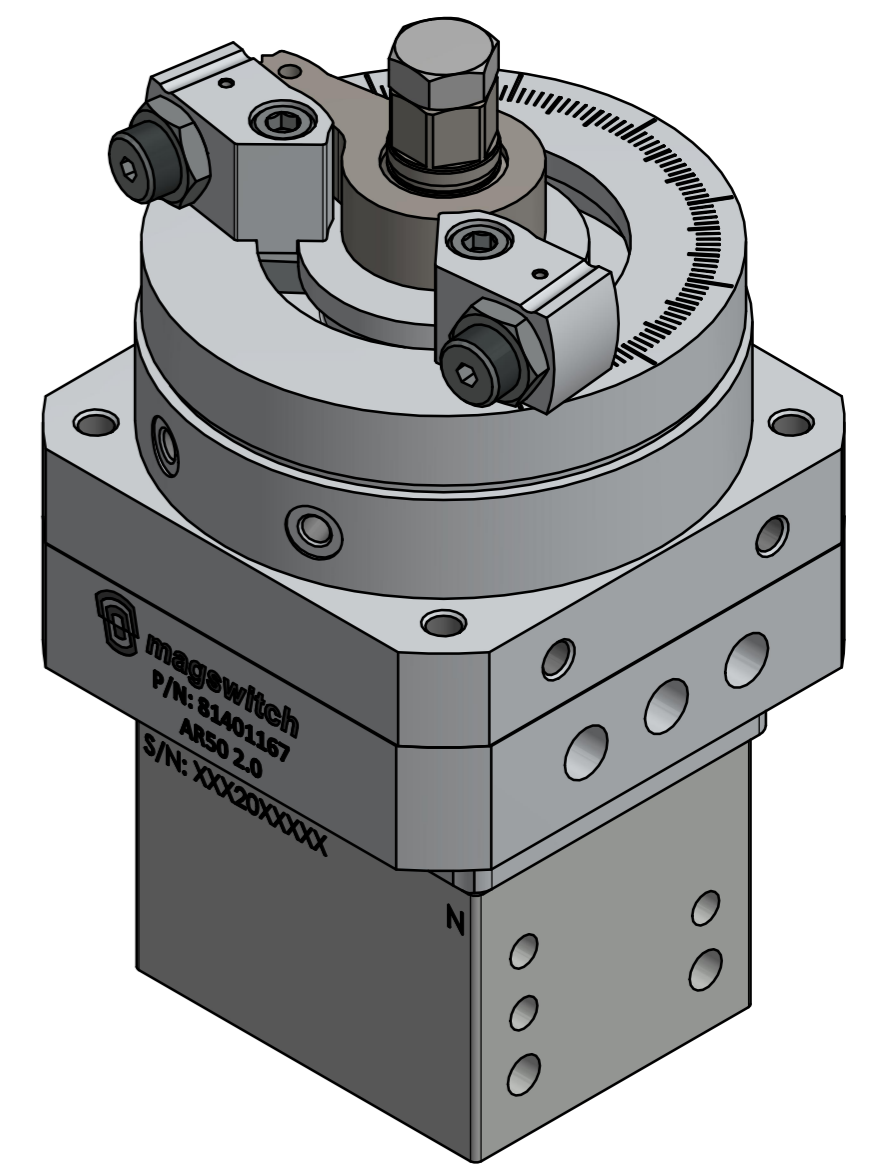
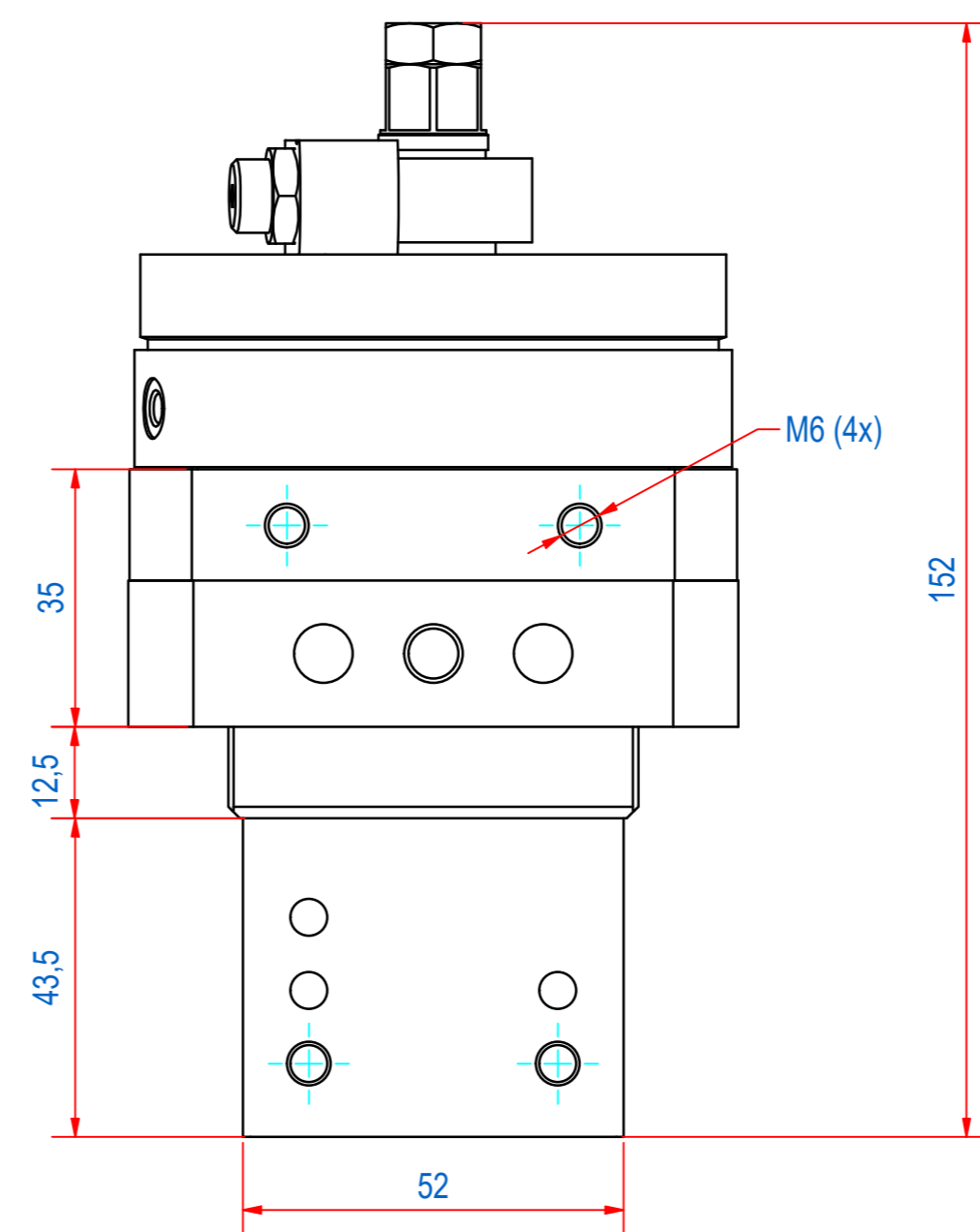
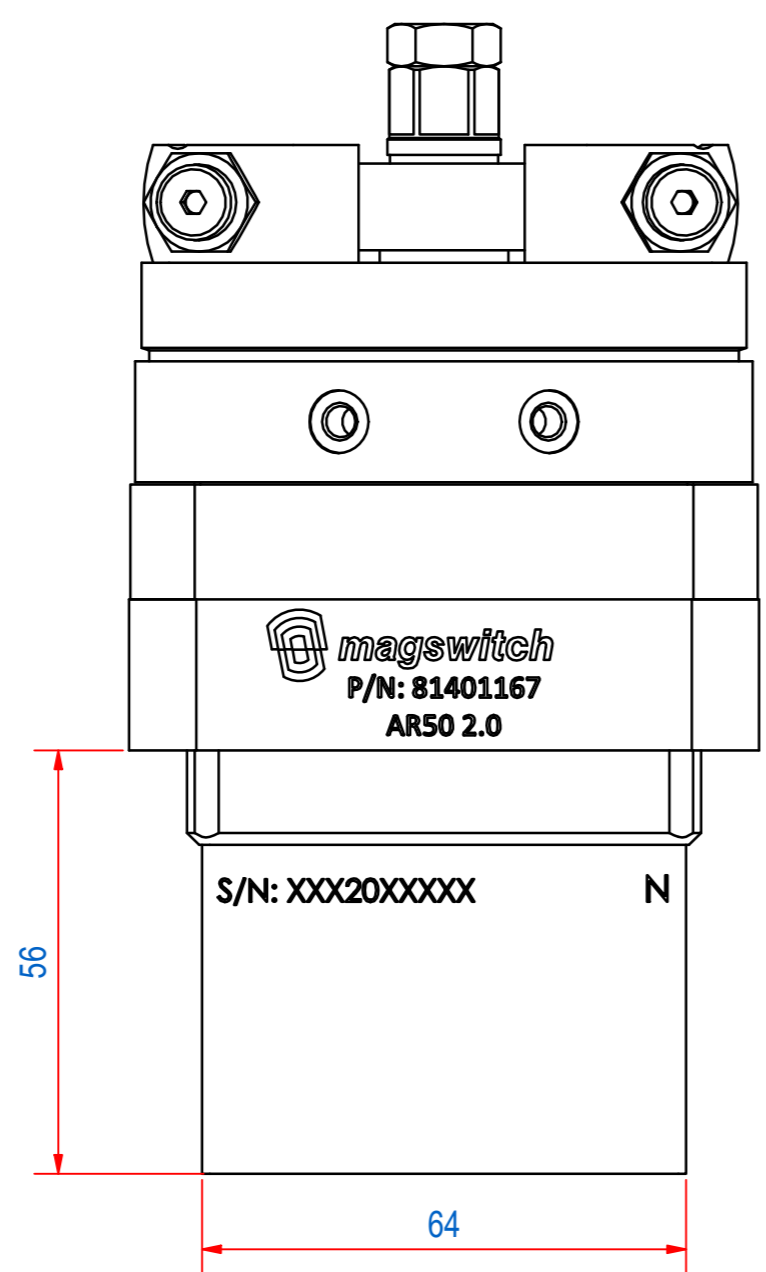
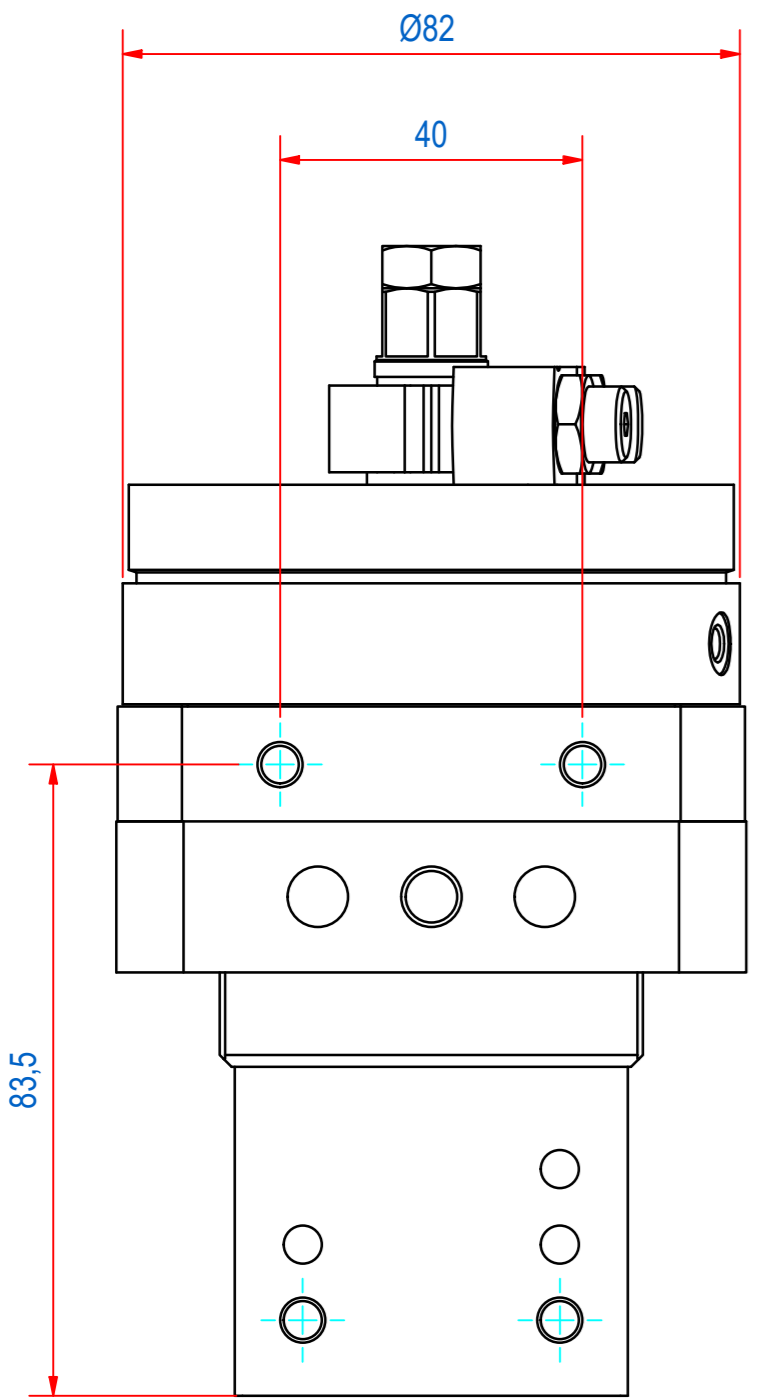
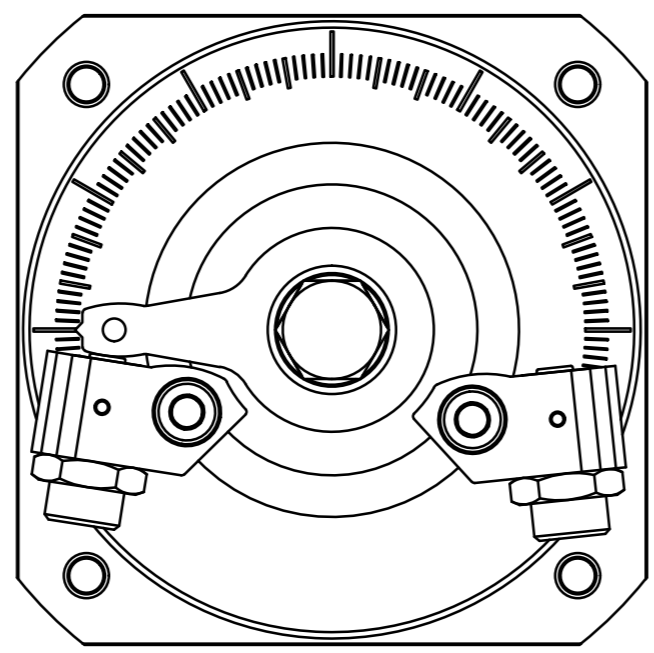

RAW MAT.	1				
Quantity	Material Number	Material Description	Length (mm)	Width (mm)	
Quantity	Sheet: A2	Extra info:	General tolerance: ISO 2768 - mK		
Drawn: JVe	Weight (kg): 3,3		Drawn according: ISO286; ISO1101; ISO2553		
Date: 17-2-2020	Source: MC-C	GOUDSMIT MAGNETICS	Status: Standard		
Spare part: False	Quick search: MS050X1		Customer reference number:		
Description: HMS-AR50 HDC-50MM		© All rights reserved. Reproduction is not permitted without written permission of GOUDSMIT Magnetic Systems BV		Document number: MS-81401167	Doc.Rev: -
			Part number: MS-81401167	Rev: -	