

REV	DATE	BY	DESCRIPTION
A	22.02.2013	PH	ORIGINAL DRAWING
B	9.11.2016	PH	NEW STANDARD LENGHT (1050mm)

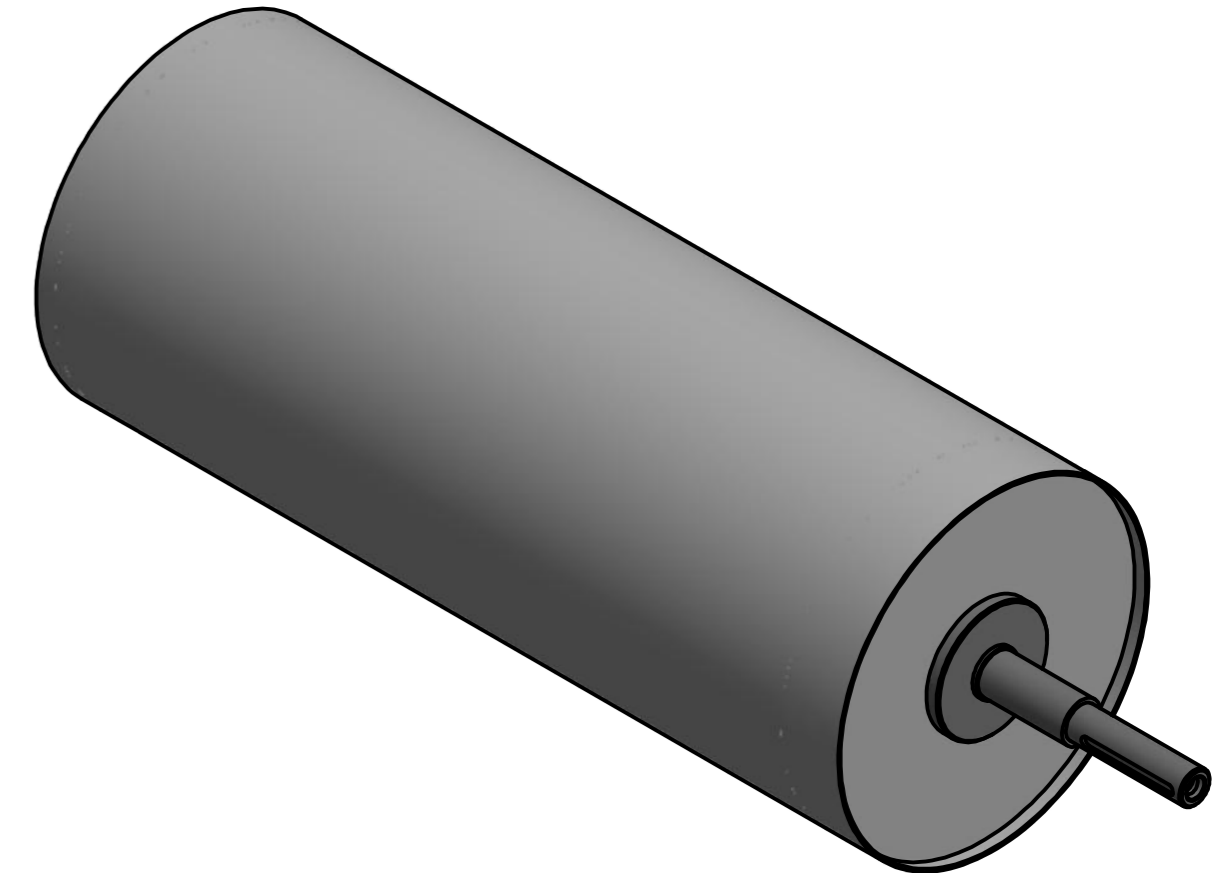
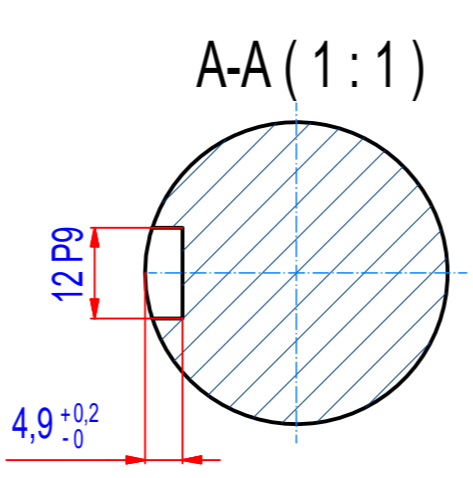
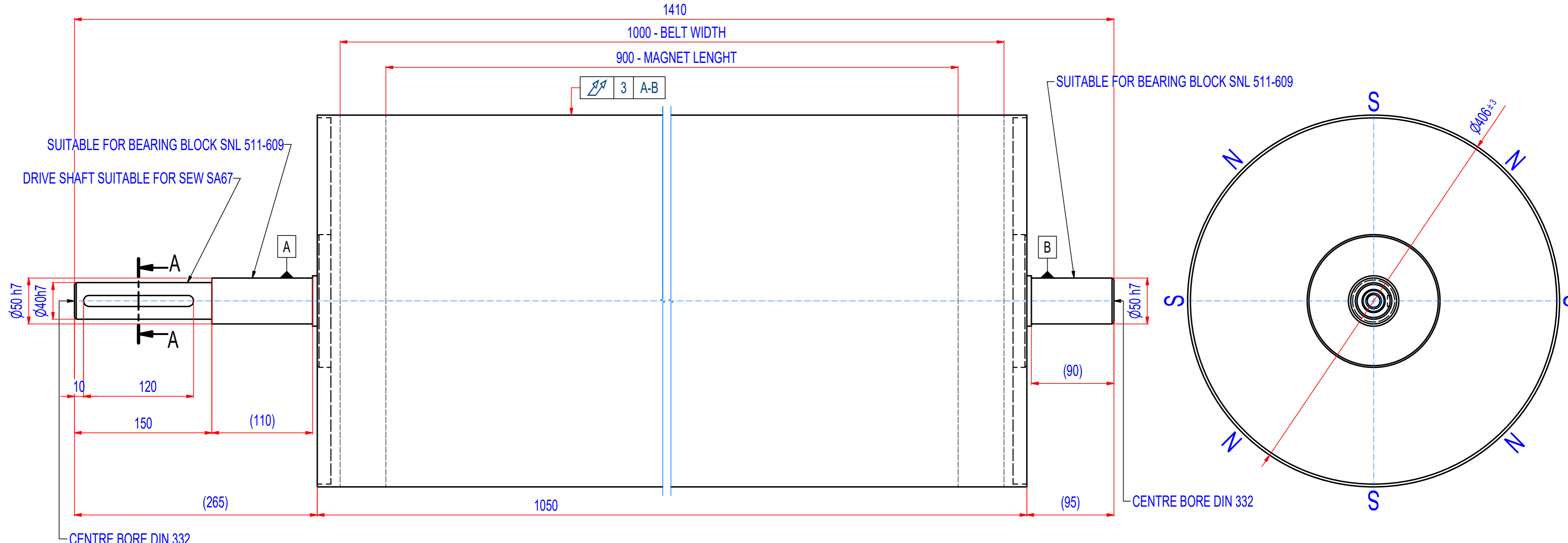

SPECIFICATIONS

- SUITABLE FOR BELT WIDTH: 1000 mm
- MAGNET TYPE: Ferrite
- NUMBER OF POLES: 8
- SURFACE MAG. INTENSITY: 1800 Gauss
- SHAFT TYPE: REMOVABLE,EQUIPPED WITH CLAMP BUSHINGS
- OVERALL WEIGHT: 504 kg
- CROWNING: NO
- RUBBER LAYER: NO

IF NOT SPECIFIED ON DRAWING, LINEAR DIMENSION TOLERANCES PER ISO 2768-1 CLASS C , GEOMETRICAL TOLERANCES PER ISO 2768-1 CLASS L

Sheet: A2	Extra info:	General tolerance: ISO 2768 - cL
Drawn: PH	Weight (kg): 504	Drawn according: ISO268; ISO1101; ISO2553
Date: 22.02.2019		Status:
Predecessor:		Customer reference number:
Quick search: XRHR D406	<p>© All rights reserved. Reproduction is not permitted without written permission of GOUDSMIT Magnetic Systems BV</p>	Product key: RHP-F406A08-100-RSD-BA
Description: Magnetic headroller, Ferrite, D406 - W1050		Part number: RHAF40100000