

REV	BY	DATE	DESCRIPTION
-	PH	28.11.2016	ORIGINAL DRAWING

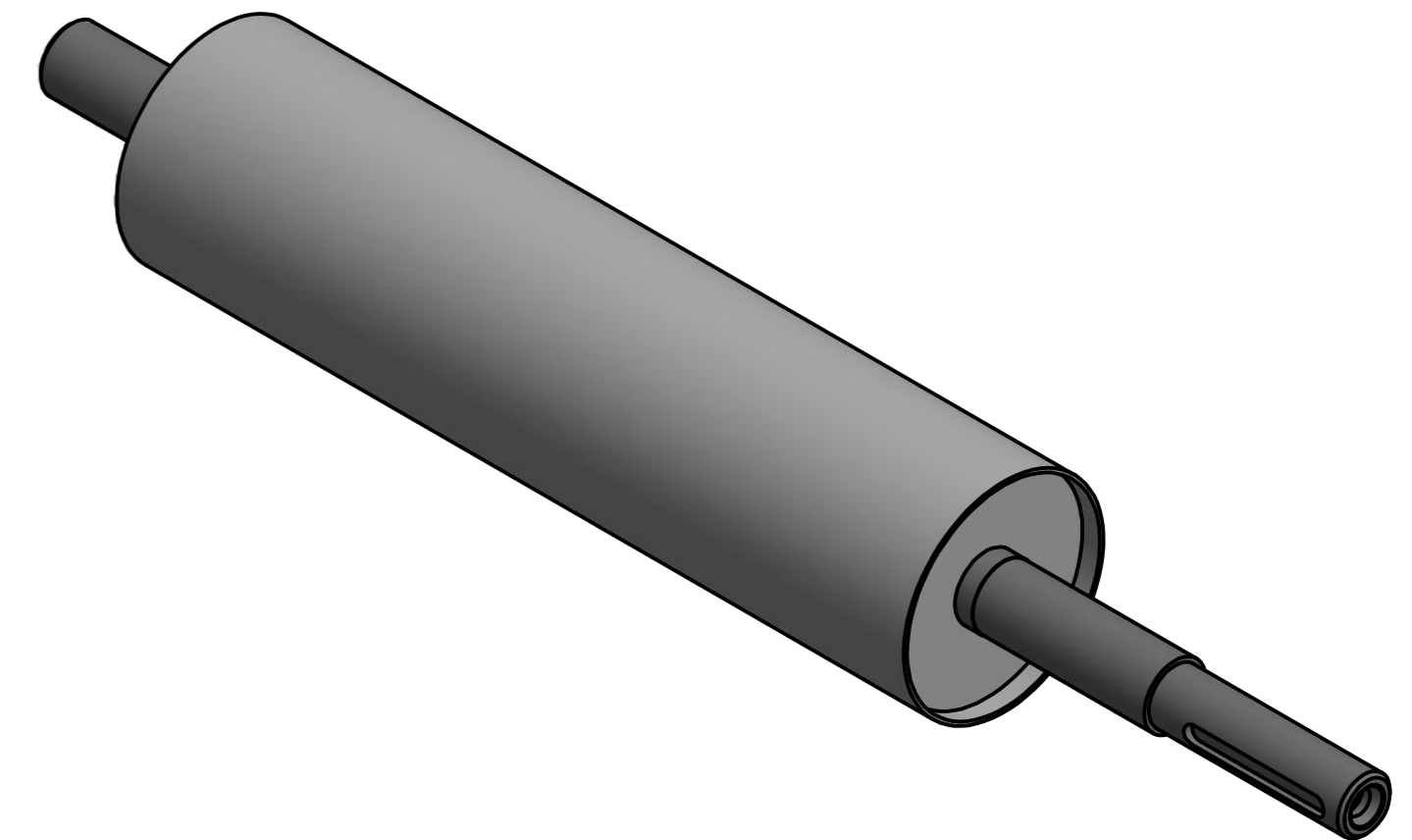
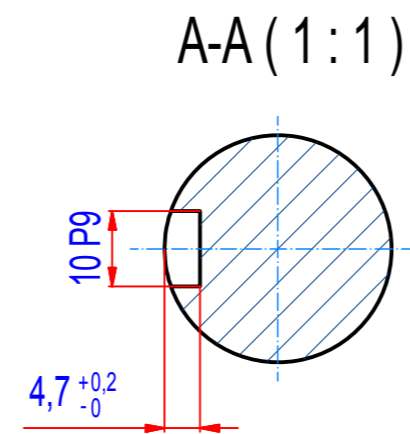
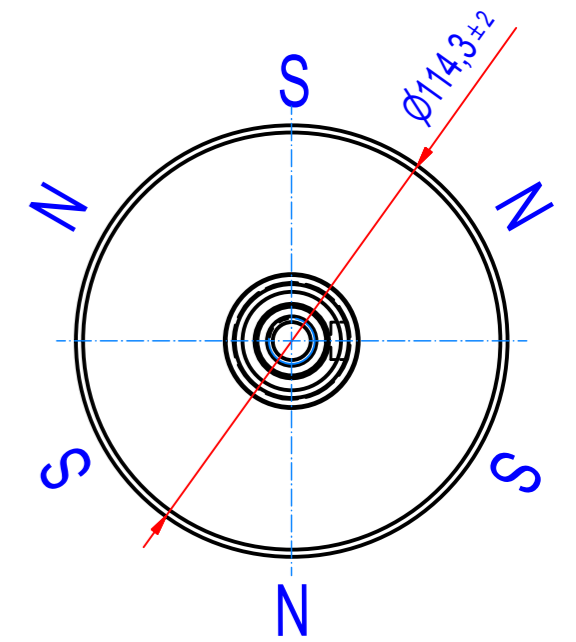
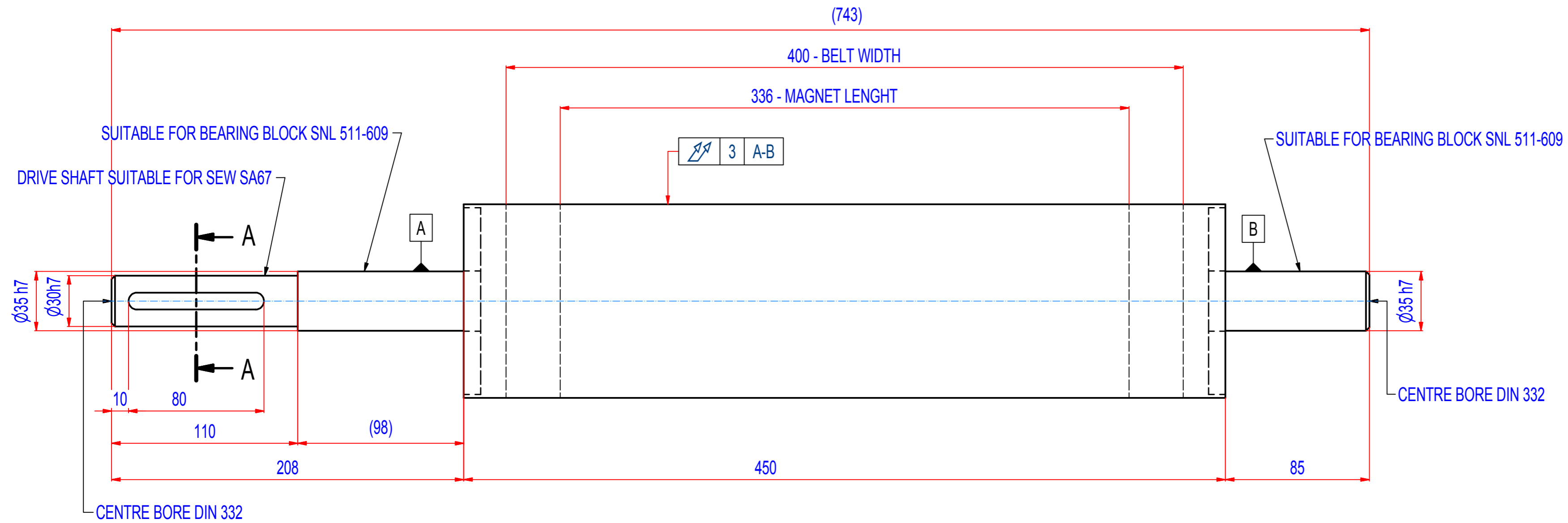

SPECIFICATIONS

- SUITABLE FOR BELT WIDTH: 400 mm
- MAGNET TYPE: NdFeB
- NUMBER OF POLES: 6
- SURFACE MAG. INTENSITY: 3700 Gauss
- SHAFT TYPE: NON REMOVABLE
- OVERALL WEIGHT: 23,1 kg
- CROWNING: NO
- RUBBER LAYER: NO

IF NOT SPECIFIED ON DRAWING, LINEAR DIMENSION TOLERANCES PER ISO 2768-1 CLASS C, GEOMETRICAL TOLERANCES PER ISO 2768-1 CLASS L

Sheet: A2	Extra info:	General tolerance: ISO 2768 - cL
Drawn: PH	Weight (kg): 23,1 kg	Drawn according: ISO268; ISO1101; ISO2553
Date: 28.11.2016		Status:
Scale: 1:2		Customer reference number:
Quick search: XRHR	© All rights reserved. Reproduction is not permitted without written permission of GOUDSMIT Magnetic Systems BV	Product key: RHP-B114A06-040-FSD-BA
Description: HEADROLLER NdFeB - D114 - W450		Part number: RHAN11040000