

REV	BY	DATE	DESCRIPTION
A	JDL	22.2.2013	ORIGINAL DRAWING
B	PH	21.11.2016	CHANGE LENGHT - NEW STANDARD(450mm)

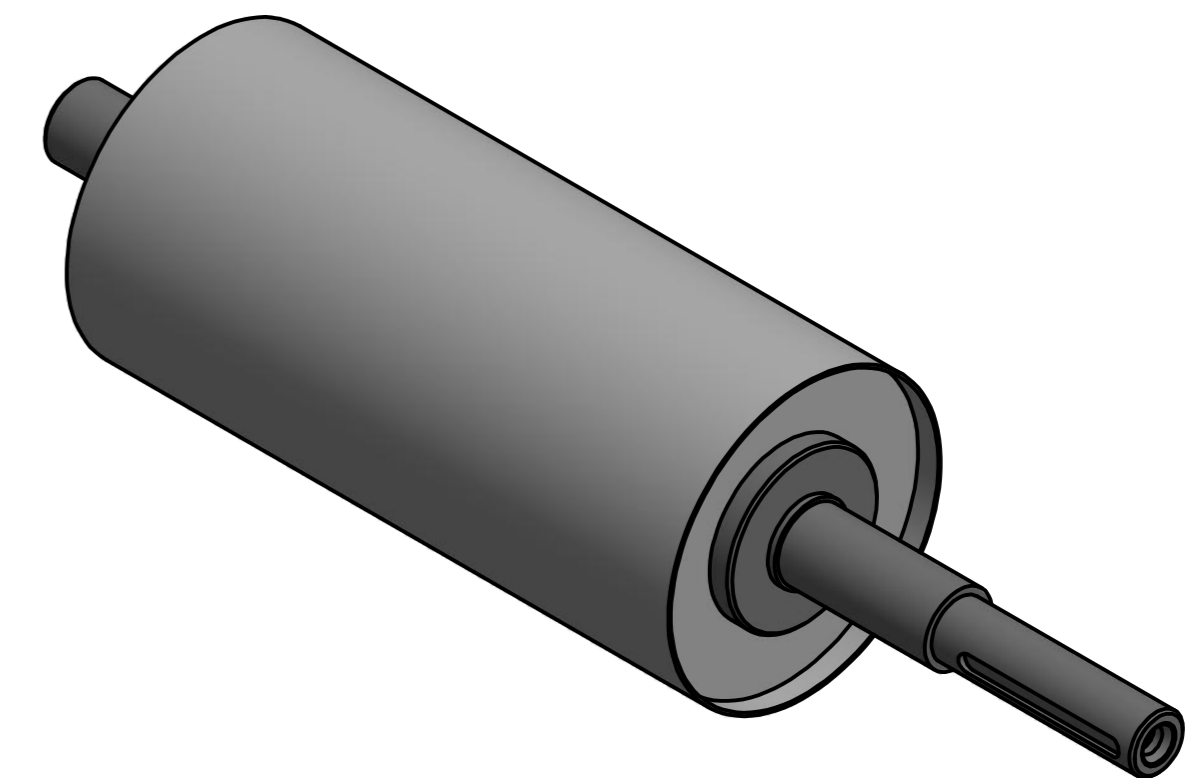
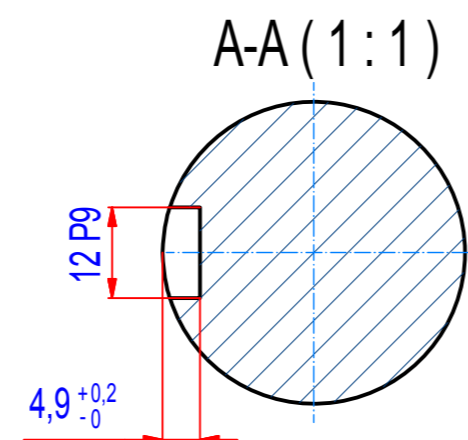
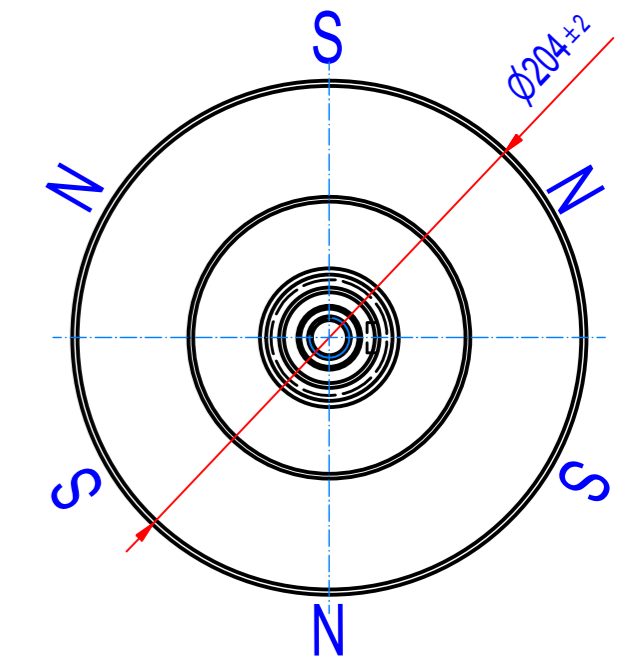
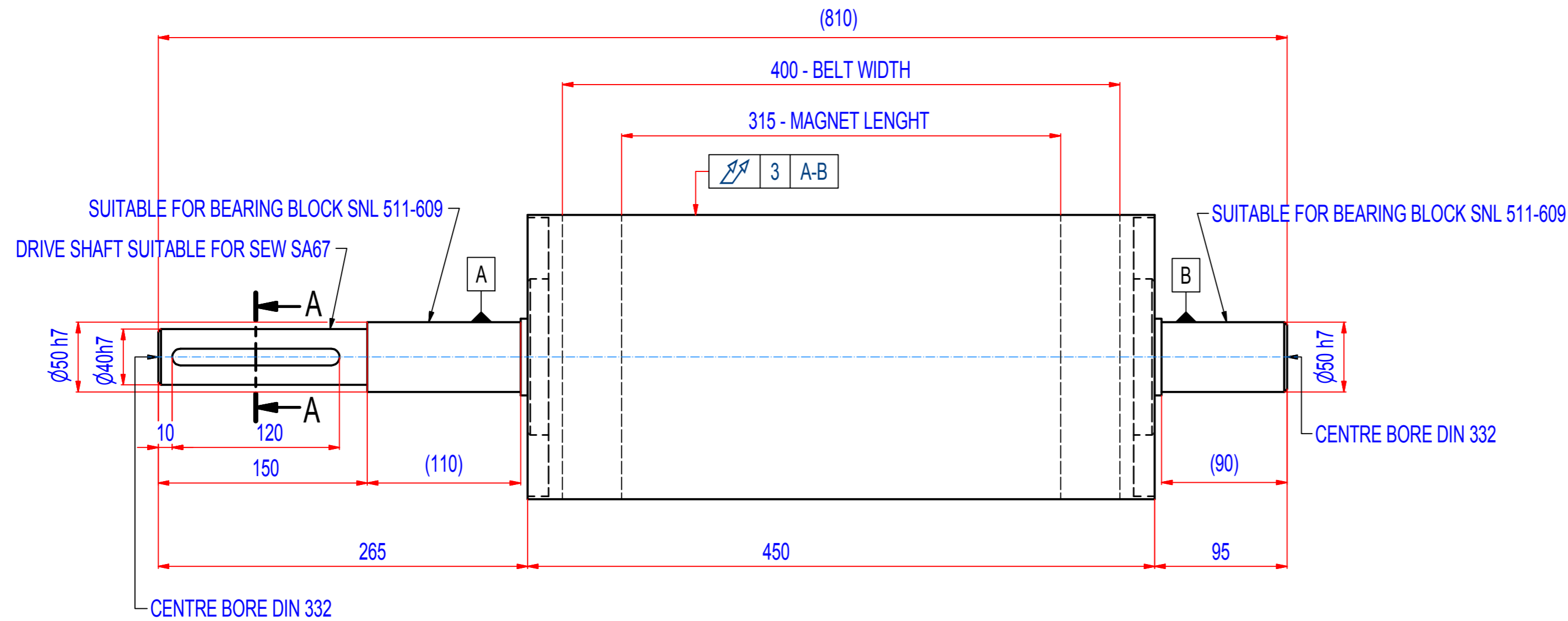

## SPECIFICATIONS

SUITABLE FOR BELT WIDTH: 400 mm

MAGNET TYPE: NdFeB

NUMBER OF POLES: 6

SURFACE MAG. INTENSITY: 3000 Gauss

SHAFT TYPE: REMOVABLE, EQUIPPED WITH CLAMP BUSHINGS

OVERALL WEIGHT: 64 kg

CROWNING: NO

RUBBER LAYER: NO

IF NOT SPECIFIED ON DRAWING, LINEAR DIMENSION TOLERANCES PER ISO 2768-1 CLASS C, GEOMETRICAL TOLERANCES PER ISO 2768-1 CLASS L

Sheet: A2	Extra info:	General tolerance: ISO 2768 - cL
Drawn: PH	Weight (kg): 64,0 kg	Drawn according: ISO268; ISO1101; ISO2553
Date: 21.11.2016	<p>© All rights reserved. Reproduction is not permitted without written permission of GOUDSMIT Magnetic Systems BV</p>	Status:
Scale: 1:3		Customer reference number:
Quick search: XRHR	Description: HEADROLLER NdFeb - D204 - W450	Product key: RHP-B204A06-040-RSD-BA
		Part number: RHAN20040000
		Rev: B