

REV	BY	DATE	DESCRIPTION
-	LF	31.01.2018	NEW VAULT - OLD.REFERENCE: ROFC065340_B
A	LF	21.09.2022	BELTS CLEATS 50mm (WAS100), MOTOR IP55 (WAS IP54)

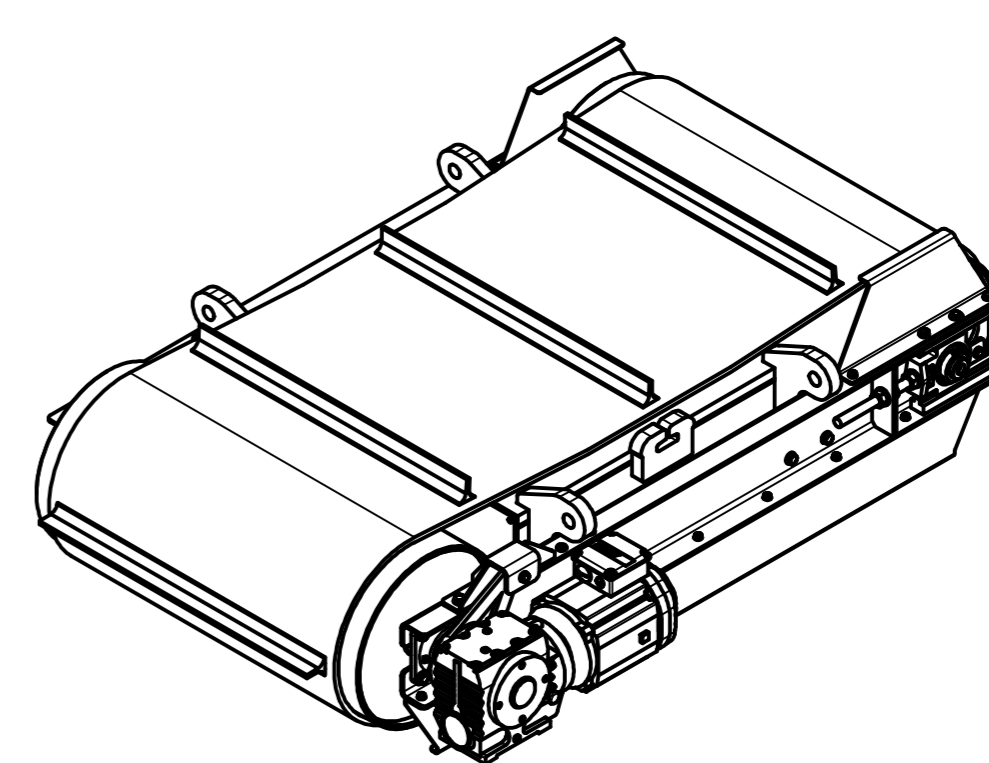
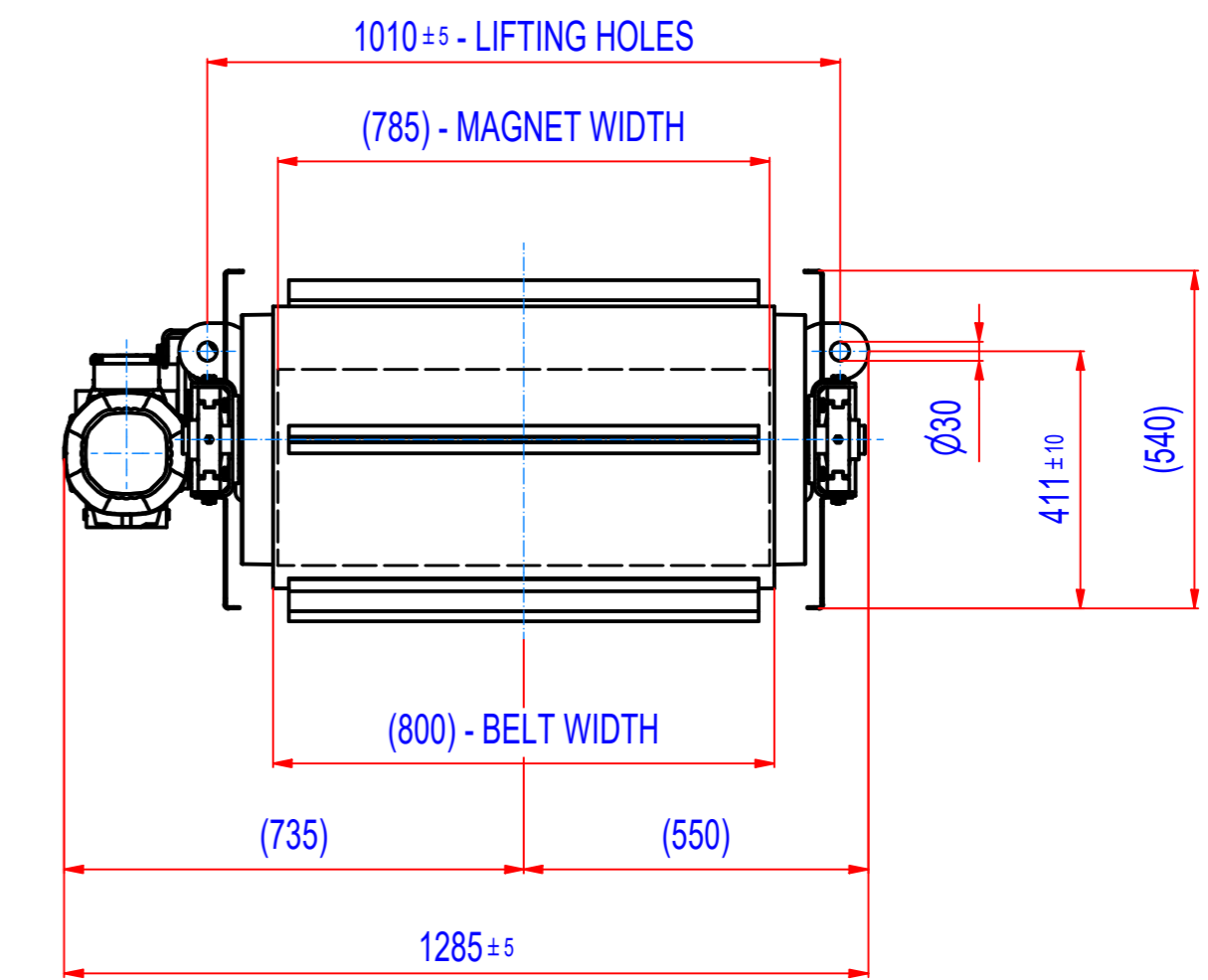
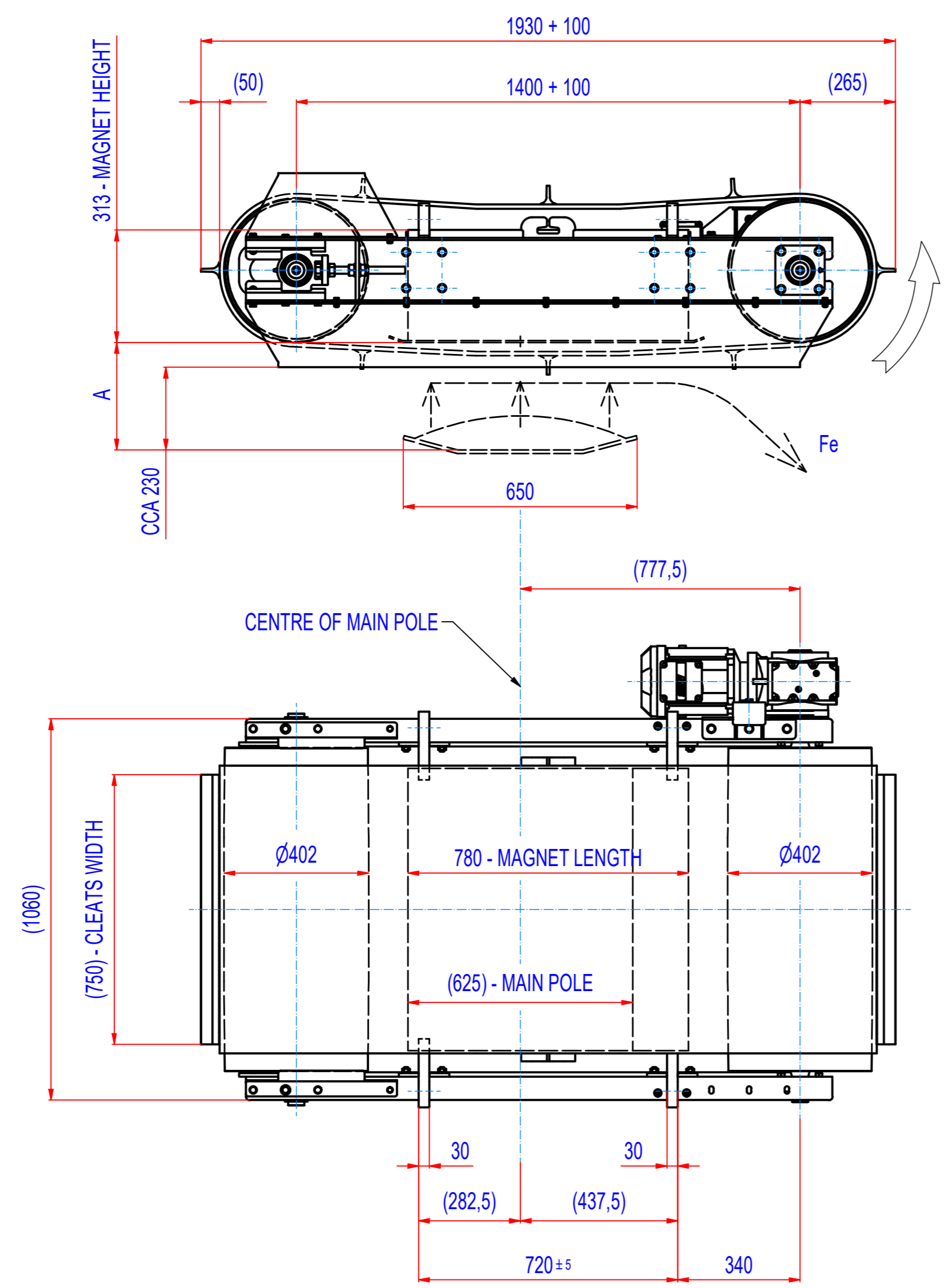

A = 380 mm - max. catch distance for rod Ø15, L=75 mm (VDE)
A = 300 mm - 400 Gs

Sheet: A2	Extra info:	General tolerance: ISO 2768 - cL
Drawn: LF	Weight (kg): 1231,6 kg	Drawn according: ISO268; ISO1101; ISO2553
Date: 31.1.2018	<p>© All rights reserved. Reproduction is not permitted without written permission of GOUDSMIT Magnetic Systems BV</p>	Status:
Predecessor: SEPB065034		Customer reference number:
Quick search: XSPB 4	Description: Overband separator, Ferrite, Size 4, W0650, Cross	Product key: ROP-F4-C-065-W-G-L-B-B-NA
		Part number: ROFC065340
		Rev: A