

REV	DATE	BY	DESCRIPTION
-	22.05.2017	LF	ORIGINAL DRAWING, REPLACES SEPB080033
A	24.06.2021	PW	MOTOR IP55 (WAS IP54)
B	08.09.2022	LF	DRIVE 2,2kW (WAS 1,5kW)

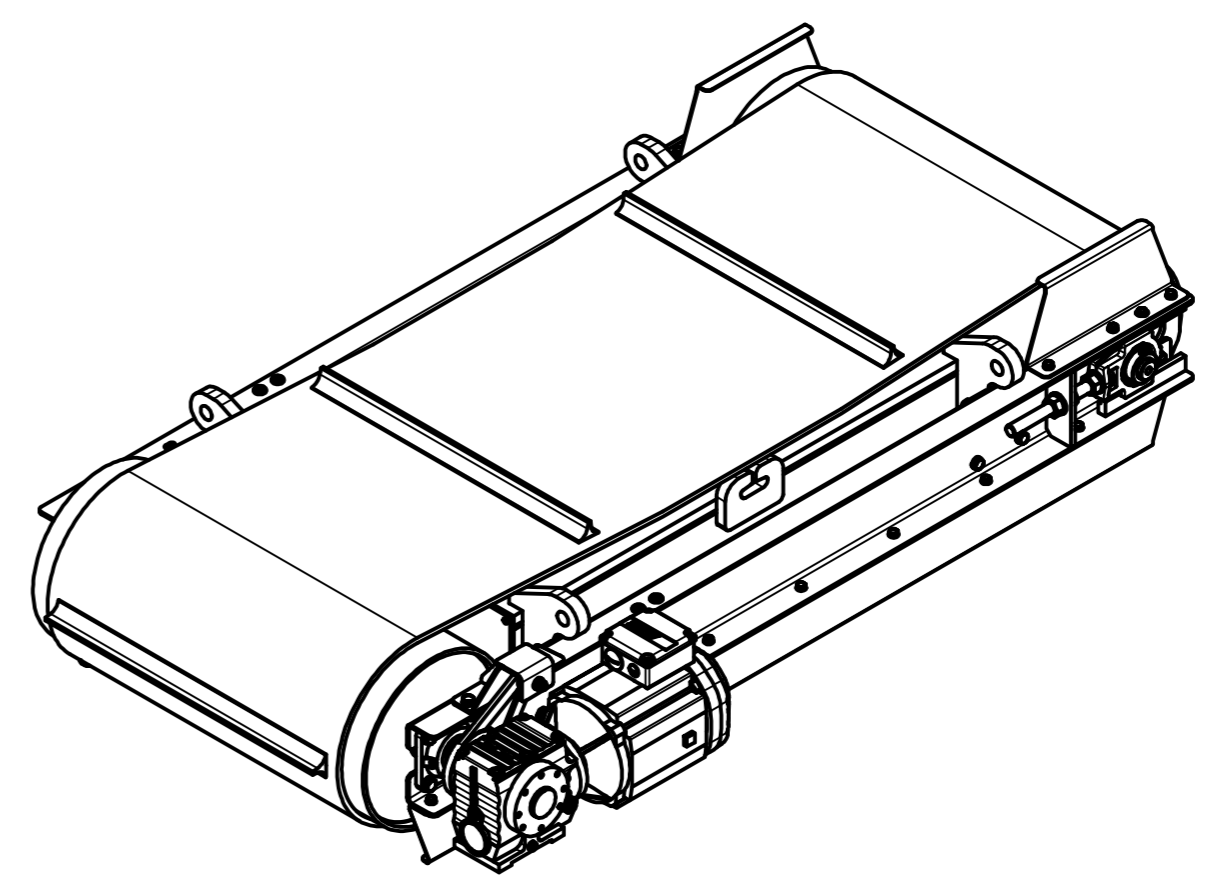
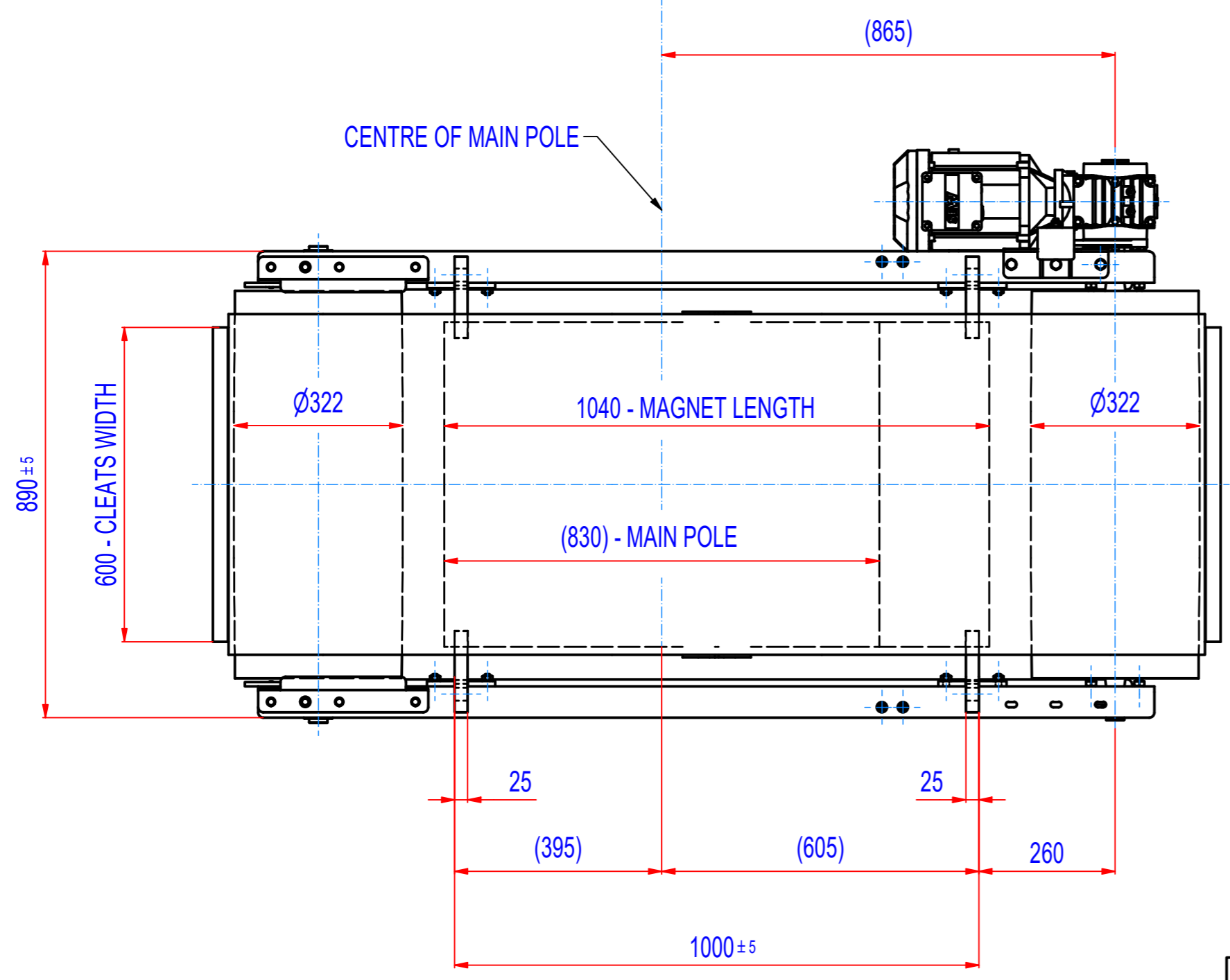
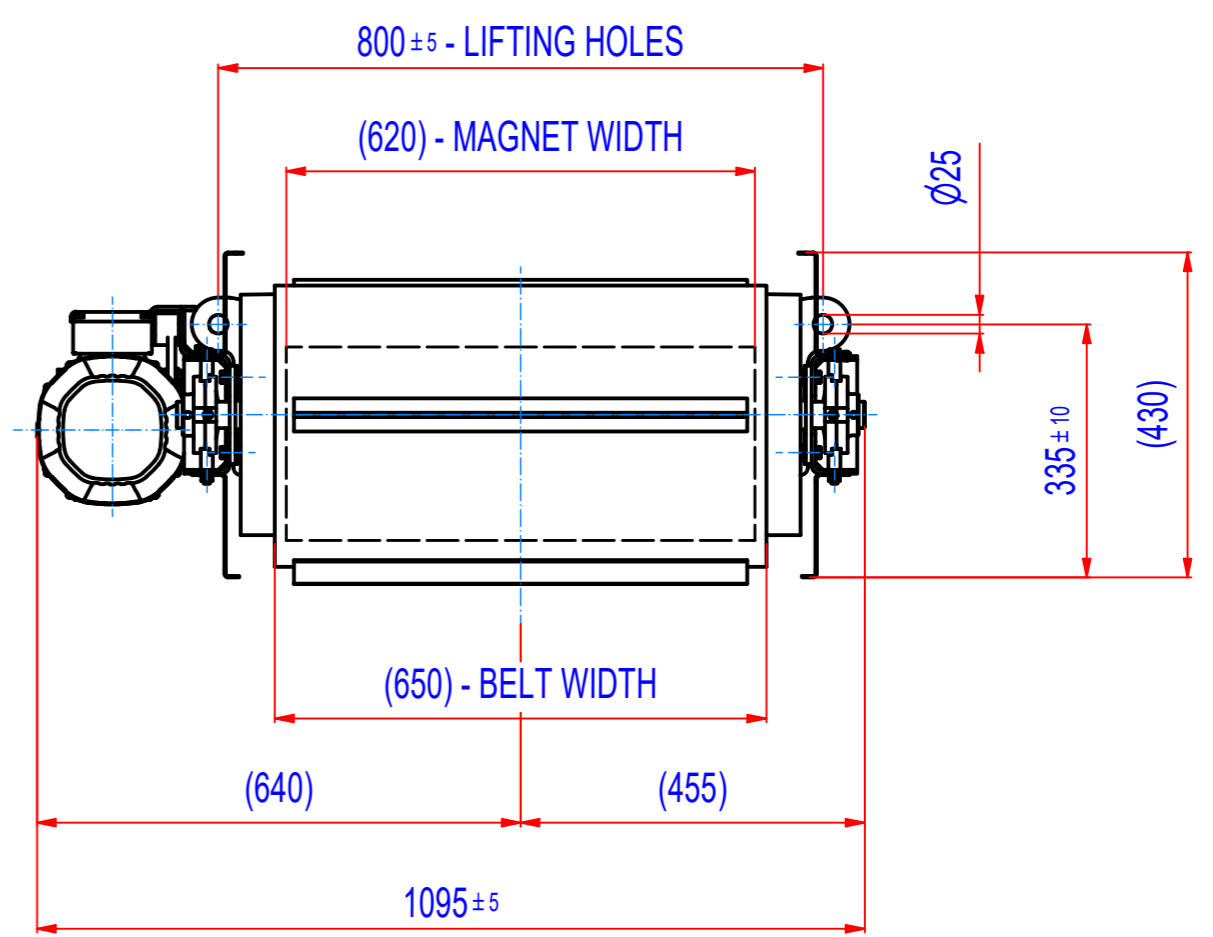
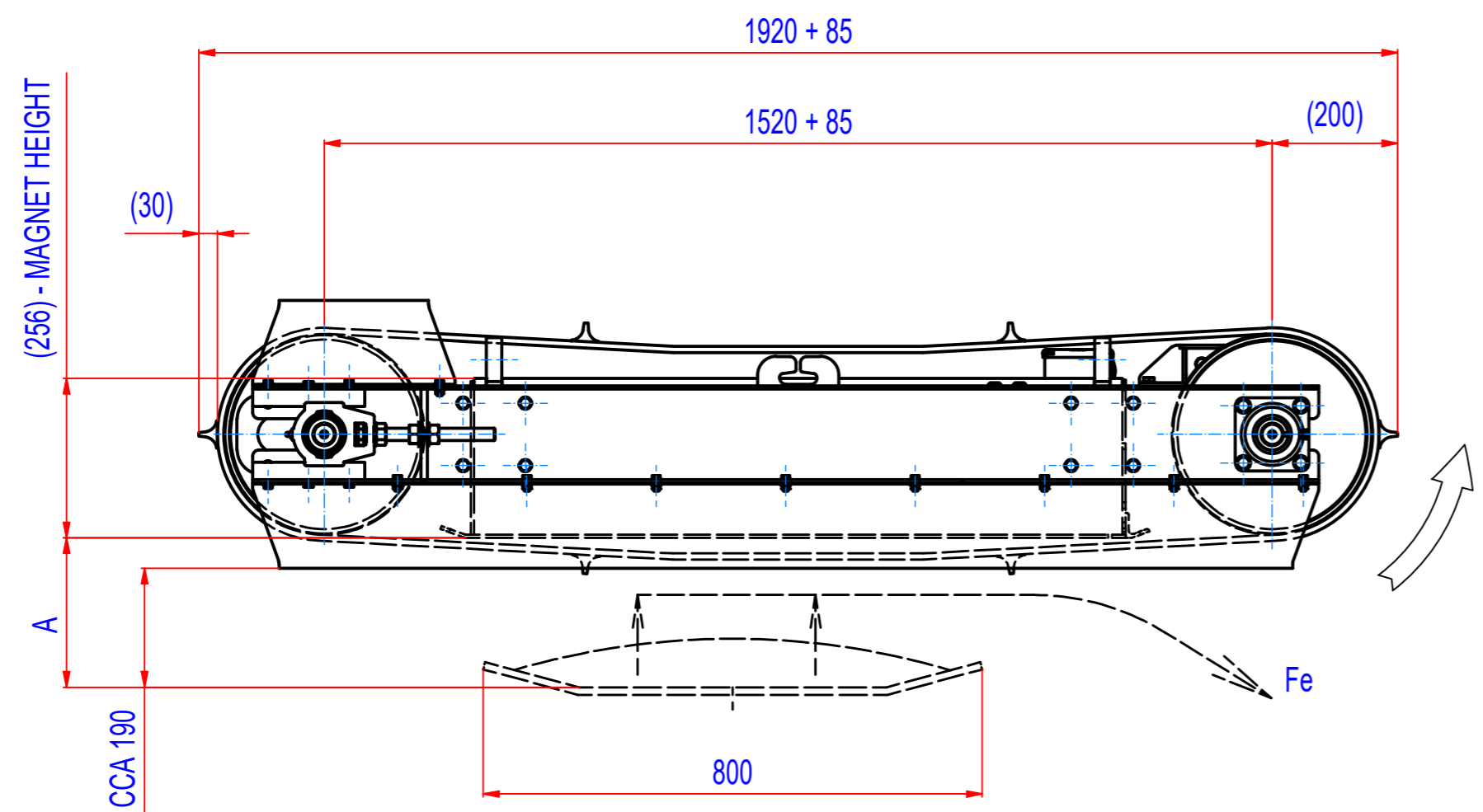

A = 320 mm - max. catch distance for rod Ø15, L=75 mm (VDE)  
A = 240 mm - 400 Gs

- GEARED BOX SEW SA57/TDRN100LS4, i=14,24 (102RPM), MOTOR 230/400V, 2,2kW, 50Hz, IP55
- DRUM SPEED 102/min
- BELT EP400/3 4+2, WIDTH 650, LENGTH 4090, 6 CLEATS T30/10, WIDTH 600
- BELT SPEED 1,7m/s

Sheet: A2	Extra info:	General tolerance: ISO 2768 - cL
Drawn: LF	Weight (kg): 872	Drawn according: ISO268; ISO1101; ISO2553
Date: 31.10.2022	<p>© All rights reserved. Reproduction is not permitted without written permission of GOUDSMIT Magnetic Systems BV</p>	Status:
Predecessor: SEPB080033		Customer reference number:
Quick search: XSPB 3		Product key: ROP-F3-C-080-W-G-L-B-B-NA
Description: Overband separator, Ferrite, Size 3, W0800, Cross	Part number: ROFC080330	Rev: B