

REV	BY	DATE	DESCRIPTION
-	PH	09.07.2017	NEW VAULT, OLD REFERENCE ROFC080340_B
A	LF	12.03.2023	BELT CLEATS 50mm (WAS 100), MOTOR IP55 (WAS IP54)

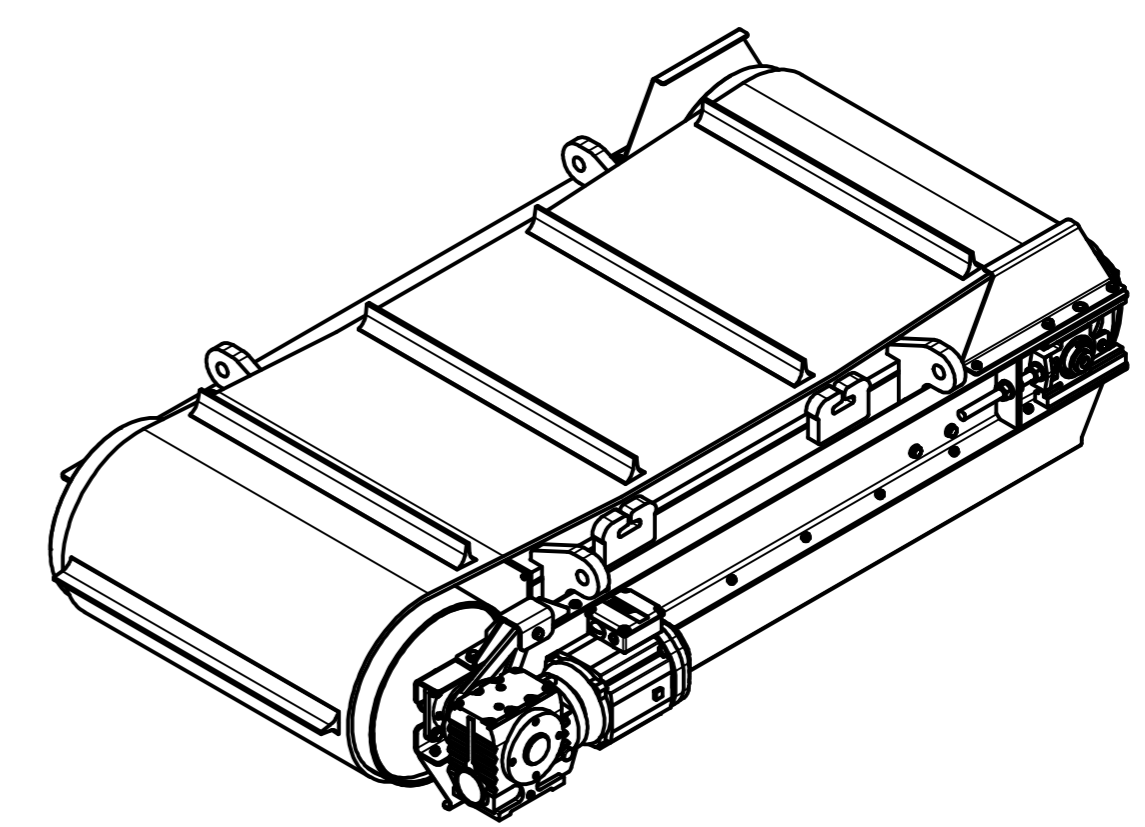
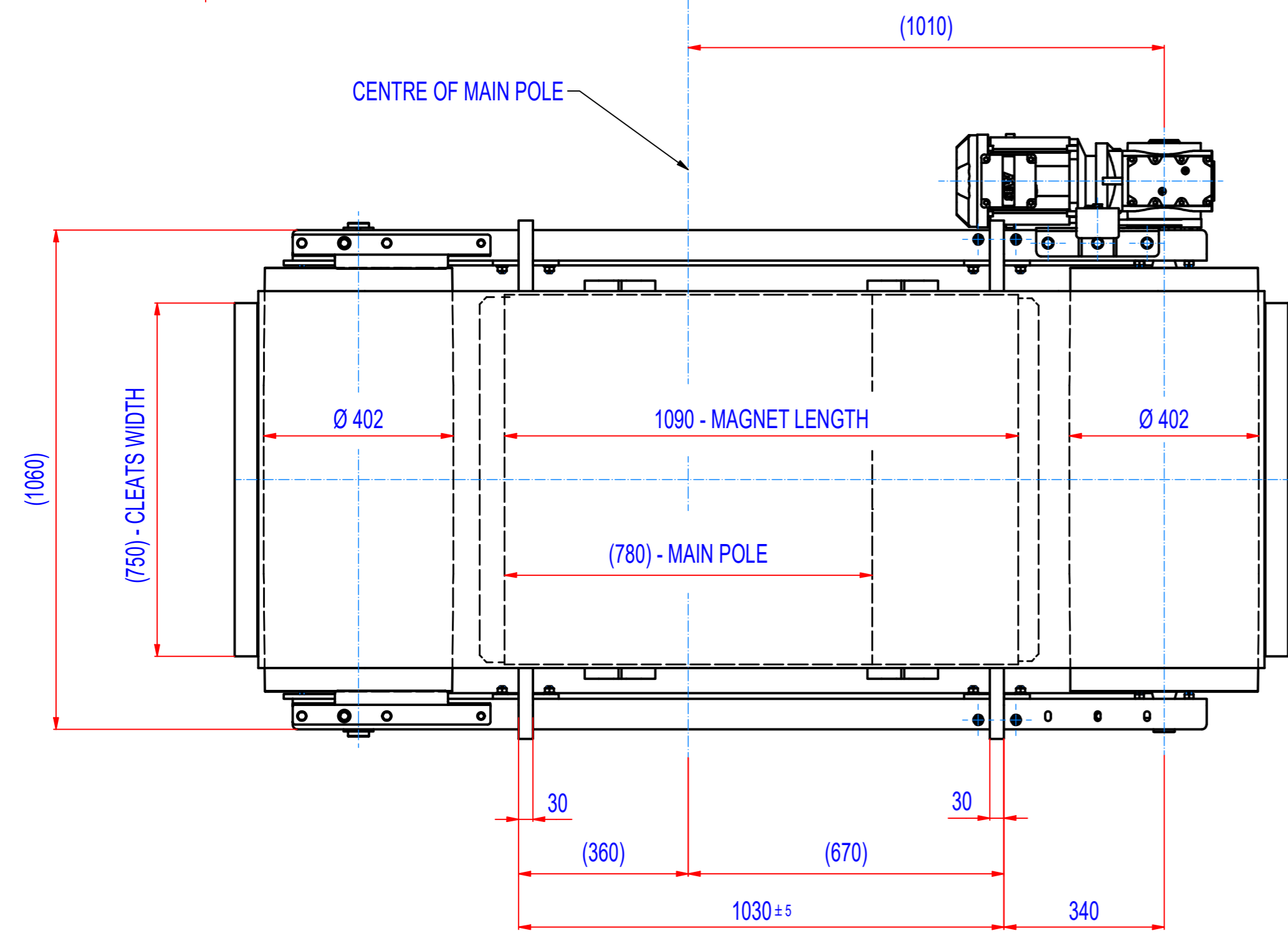
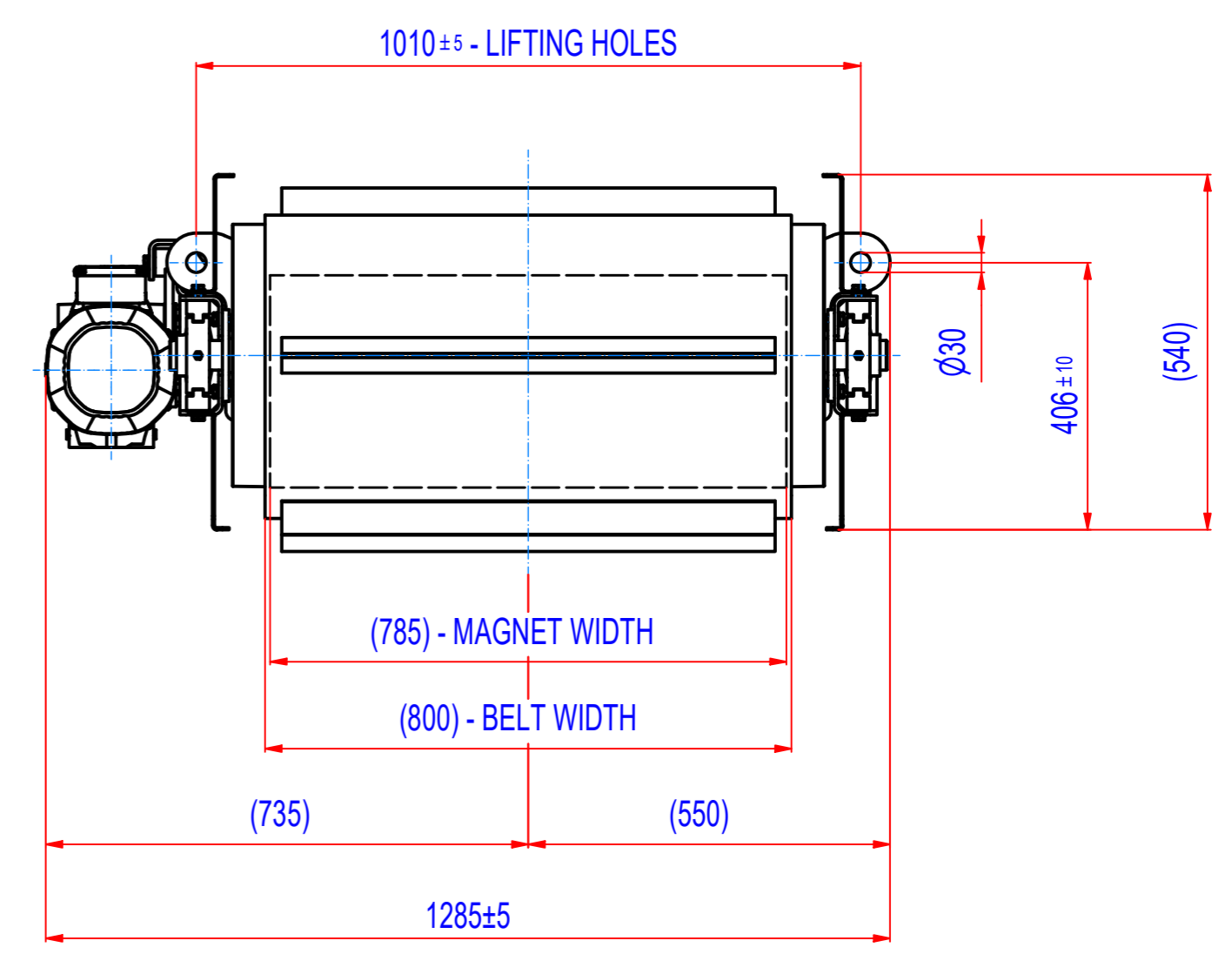
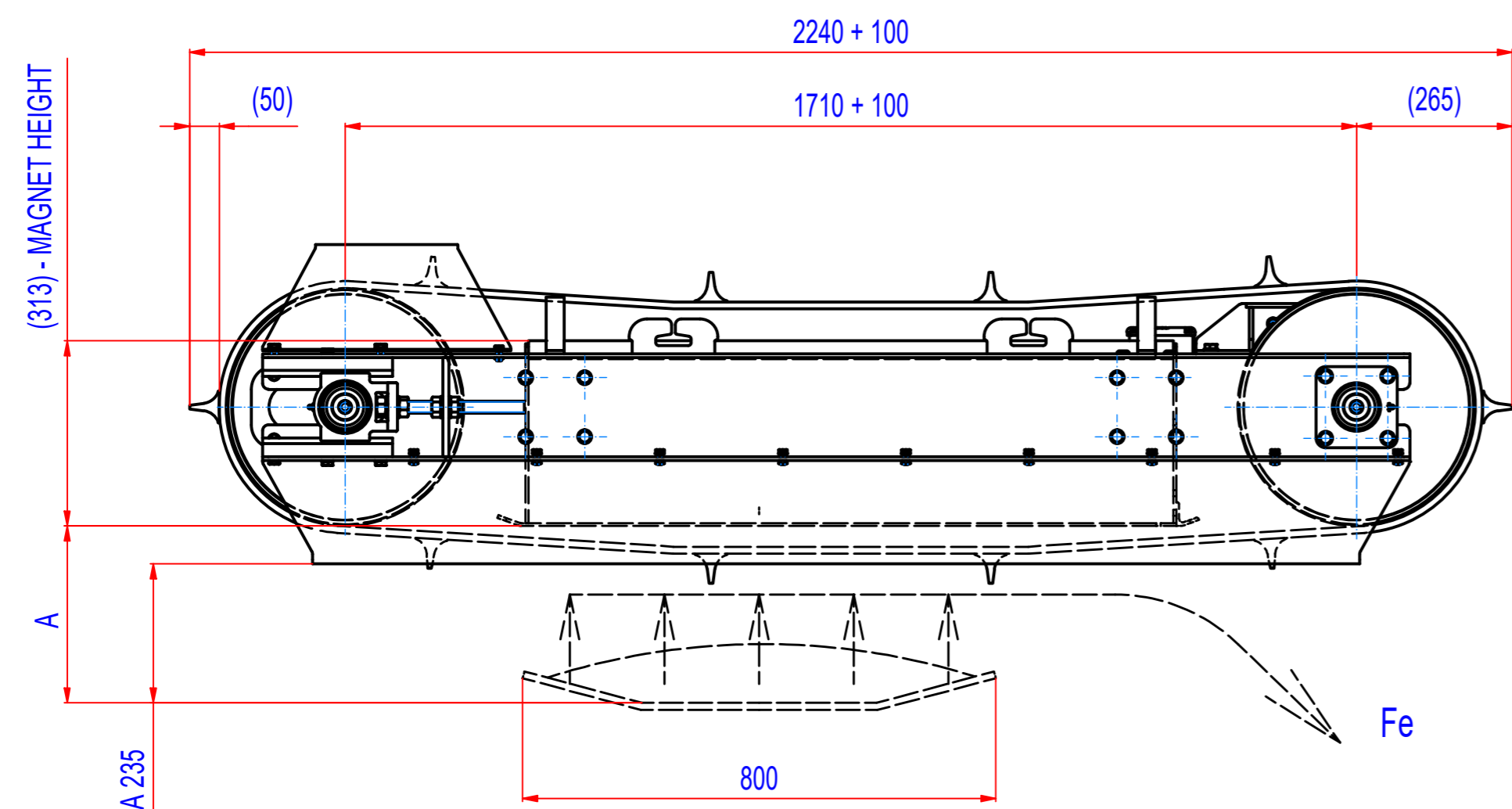

A = 380 mm - max. catch distance for rod Ø15, L=75 mm (VDE)  
A = 300 mm - 400 Gs

- GEARED BOX SEW SA67/TDRN100LS4, i=20,37 (71RPM), MOTOR 230/400V, 2,2kW, 50Hz, IP55
- DRUM SPEED: 71/min
- BELT SPEED: 1,5m/s
- BELT EP500, LENGTH 4730, WIDTH 800, 10 CLEATS T50/10, WIDTH 750

Sheet: A2	Extra info:	General tolerance: ISO 2768 - cL
Drawn: PH	Weight (kg): 1534,7 kg	Drawn according: ISO268; ISO1101; ISO2553
Date: 30.6.2017	Predecessor: SEPB080034	Status:
Quick search: XSPB 4	Description: Overband separator, Ferrite, Size 4, W0800, Cross	Customer reference number:
<p>© All rights reserved. Reproduction is not permitted without written permission of GOUDSMIT Magnetic Systems BV</p>		Product key: ROP-F4-C-080-W-G-L-B-B-NA
		Part number: ROFC080340 Rev: A