

REV	BY	DATE	DESCRIPTION
-	LF	21.06.2018	ORIGINAL DRAWING
A	LF	12.03.2023	BELT CLEATS 50mm (WAS 100), MOTOR IP55 (WAS IP54) REDUCTION IN THE NUMBER OF SPARE PARTS

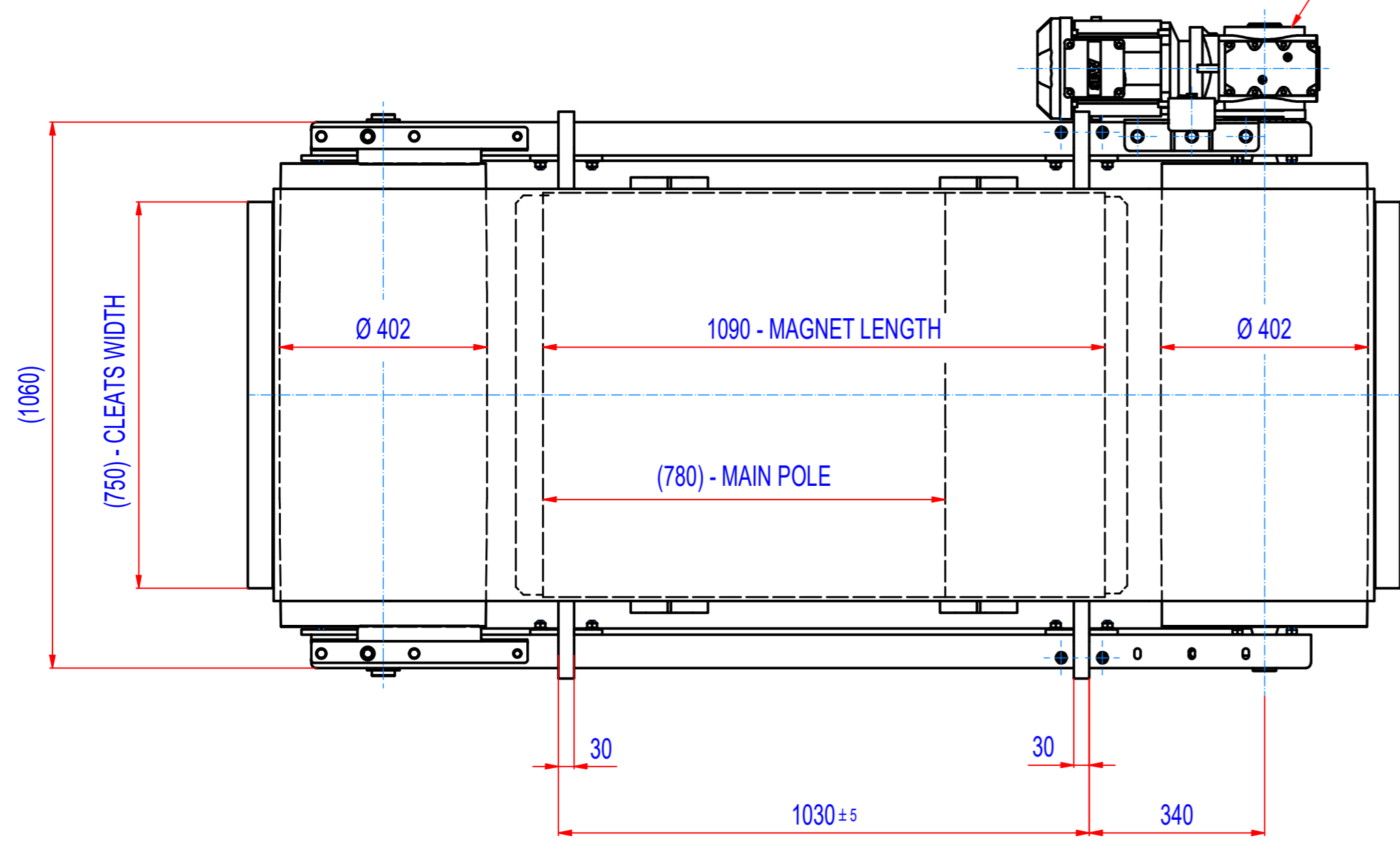
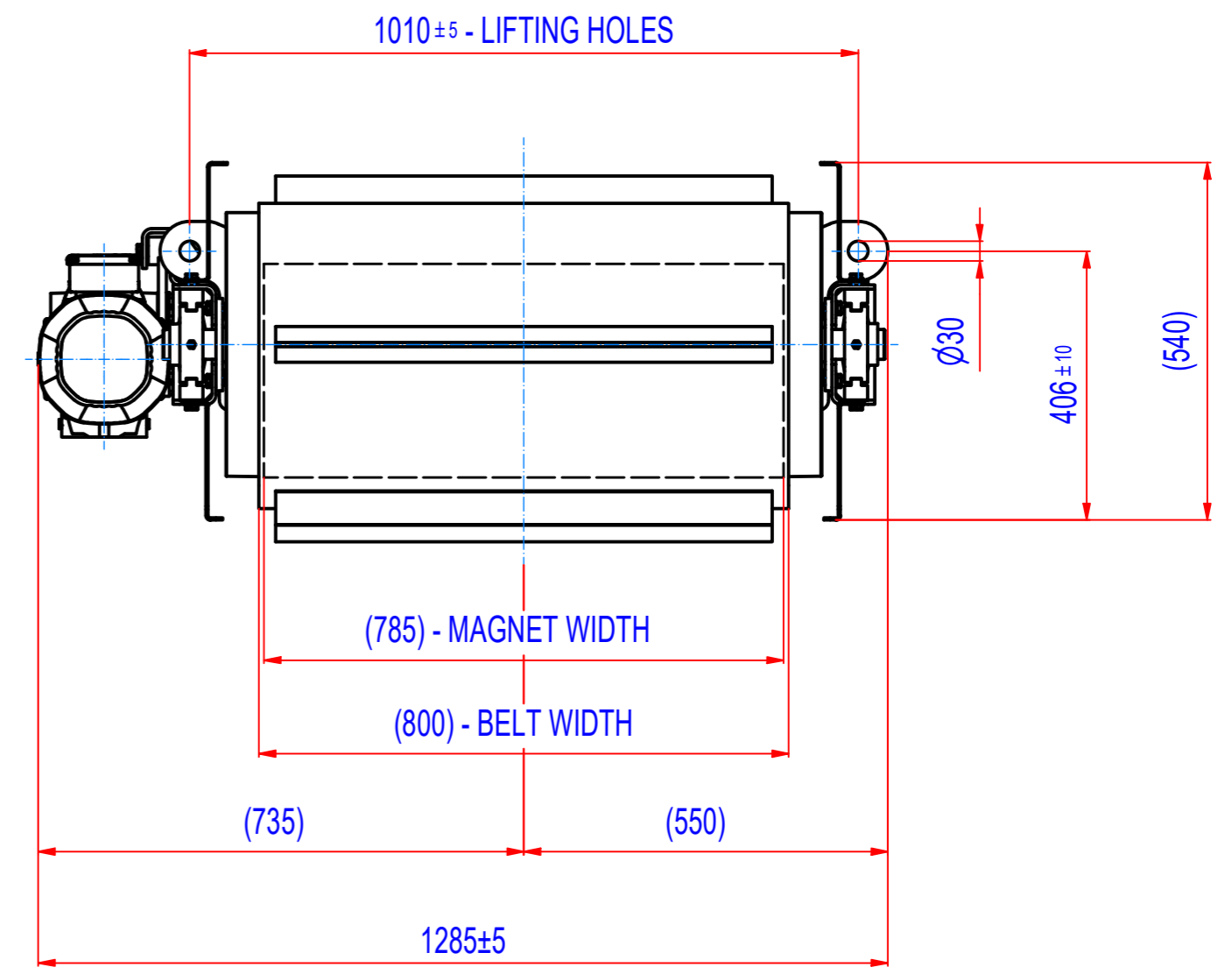
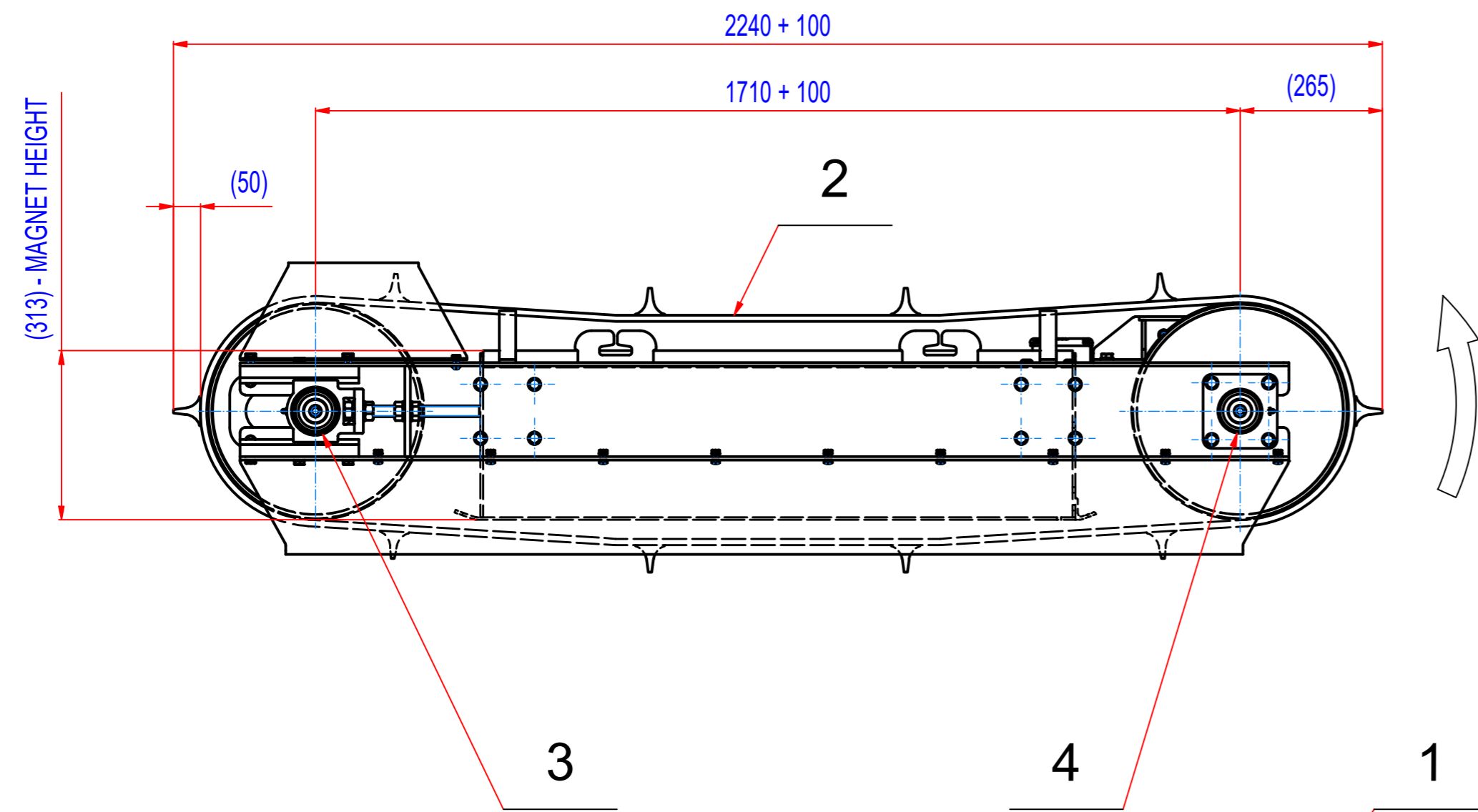

- GEARED BOX SEW SA67/TDRN100LS4, i=20,37 (71RPM),
MOTOR 230/400V, 2,2kW, 50Hz, IP55
- DRUM SPEED: 71/min
- BELT SPEED: 1,5m/s
- BELT EP500, LENGTH 4730, WIDTH 800,
10 CLEATS T50/10, WIDTH 750

POZ.	Č. SOUČÁSTI	POPIS	MATERIÁL	HMOT.	MN.
4	15_8700045	BEARINGS ASSEMBLY INA PCJ 45		2,5	2
3	15_8600045	BEARINGS ASSEMBLY INA PTUE 45		2,7	2
2	45_4080037	BELT EP500/4 5+2, W=800, L=4730	RUBBER	58	1
1	M022007132	SEW SA67/TDRN100LS4, 2,2kW, i=20,37 (71RPM)		59,2	1

Sheet: A2 Drawn: LF Date: 21.06.2018 Predecessor: SEPB080034 Quick search: XSPB 4 Description: SPARE PARTS FOR ROFC080340	Extra info: © All rights reserved. Reproduction is not permitted without written permission of GOUDSMIT Magnetic Systems BV	General tolerance: ISO 2768 - cL Drawn according: ISO268; ISO1101; ISO2553 Status: Customer reference number: Product key: ROP-F4-C-080-W-G-L-B-B-NA Part number: ROFC080340_SP Rev: A
--	--	---