

REV	DATE	BY	DESCRIPTION
-	12.04.2018	EN	New Vault, old revision was B
A	16.12.2019	PW	MOTOR IP55 (WAS IP54)
B	19.03.2023	LF	ADDED DIMENSION "A"

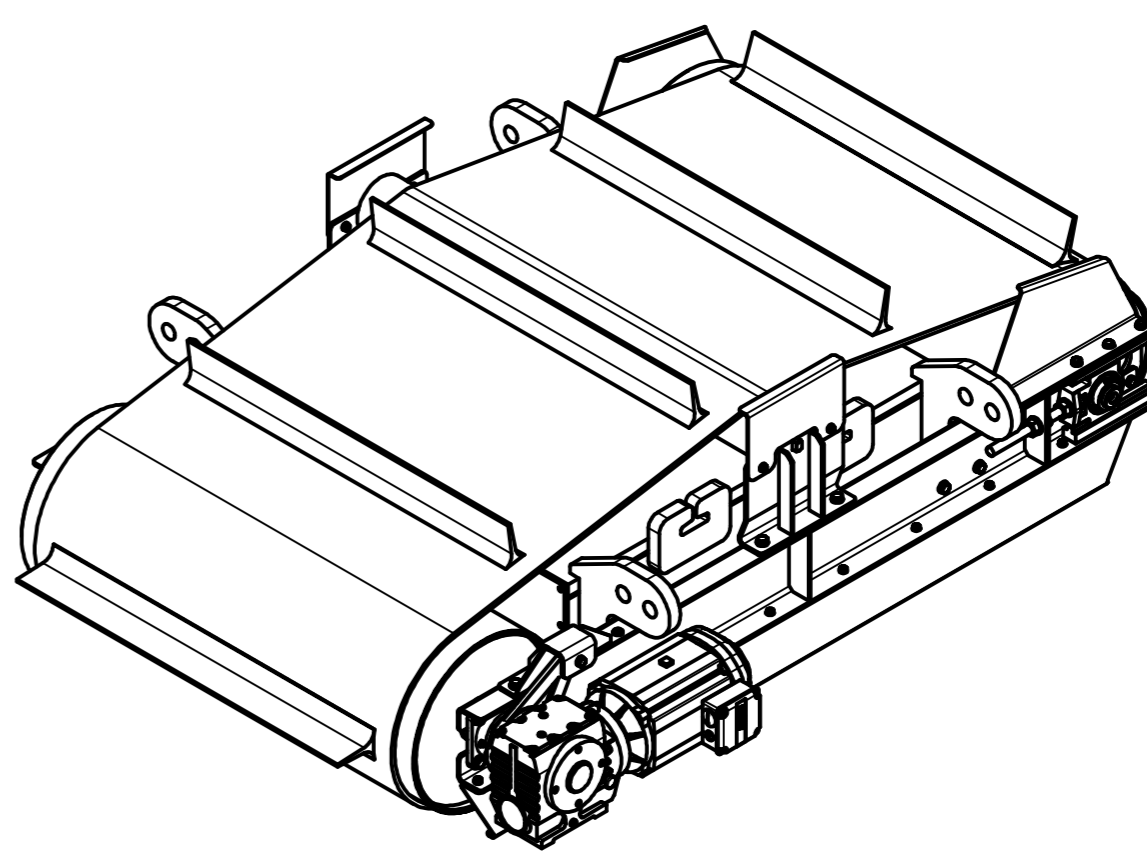
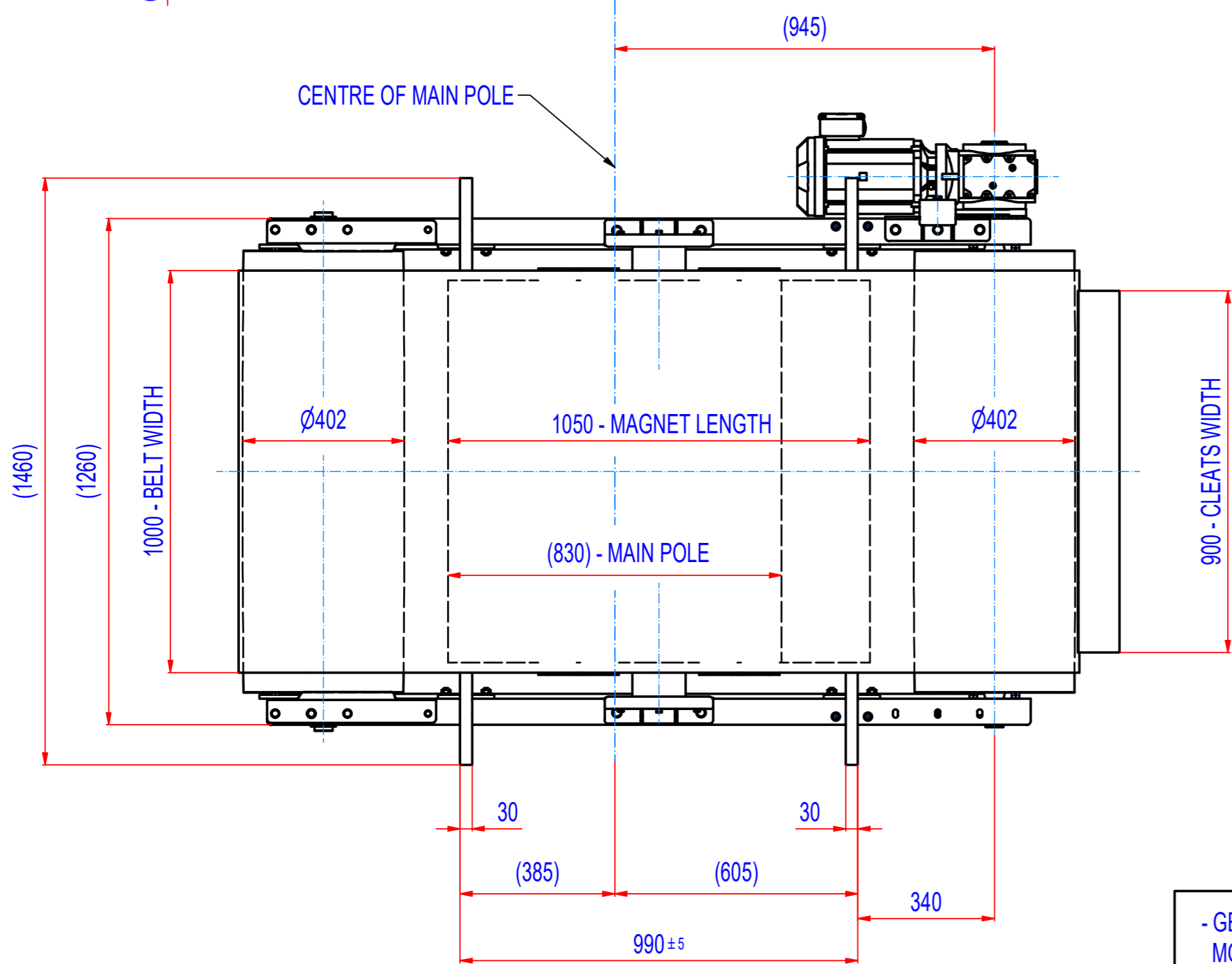
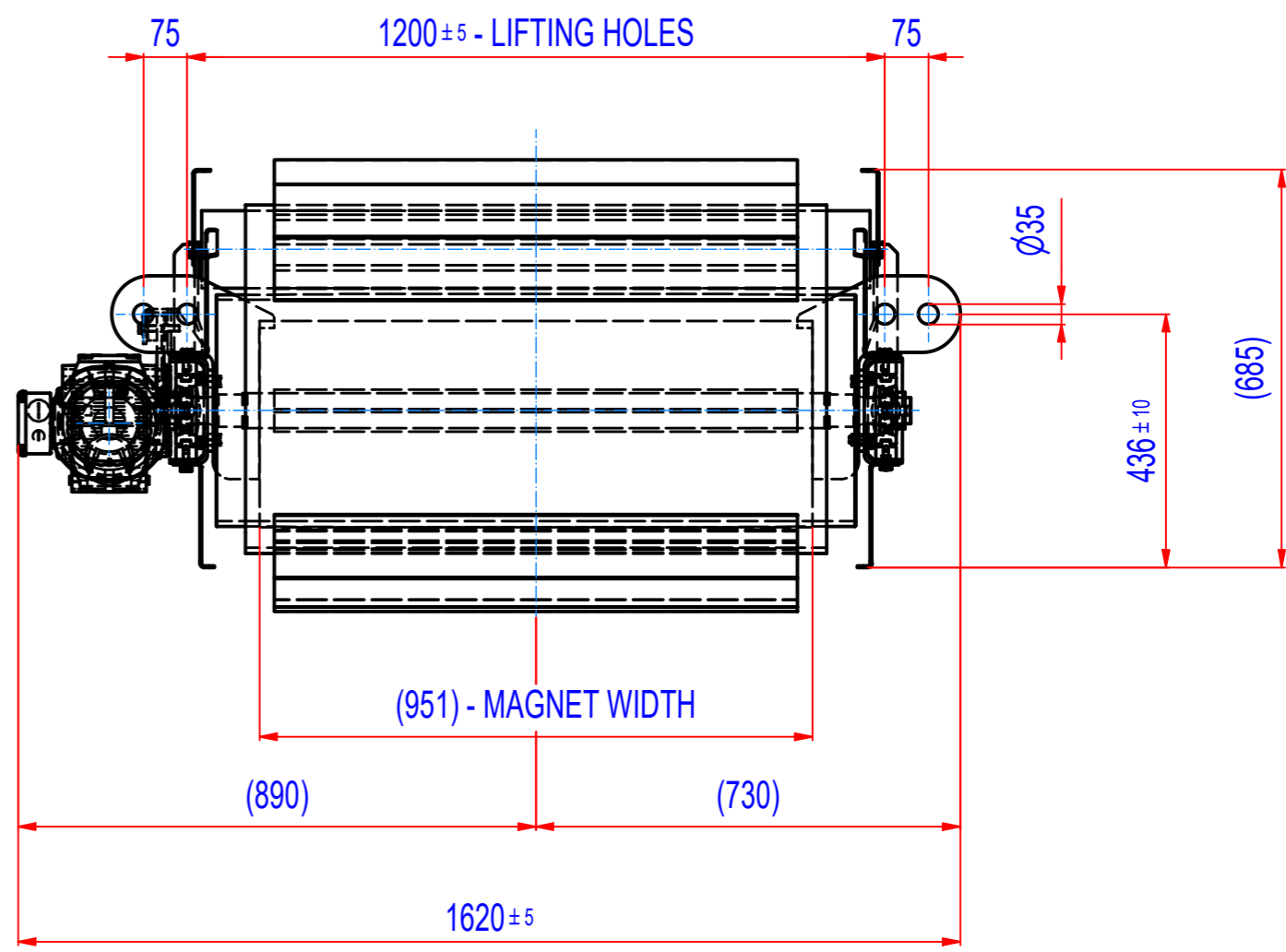
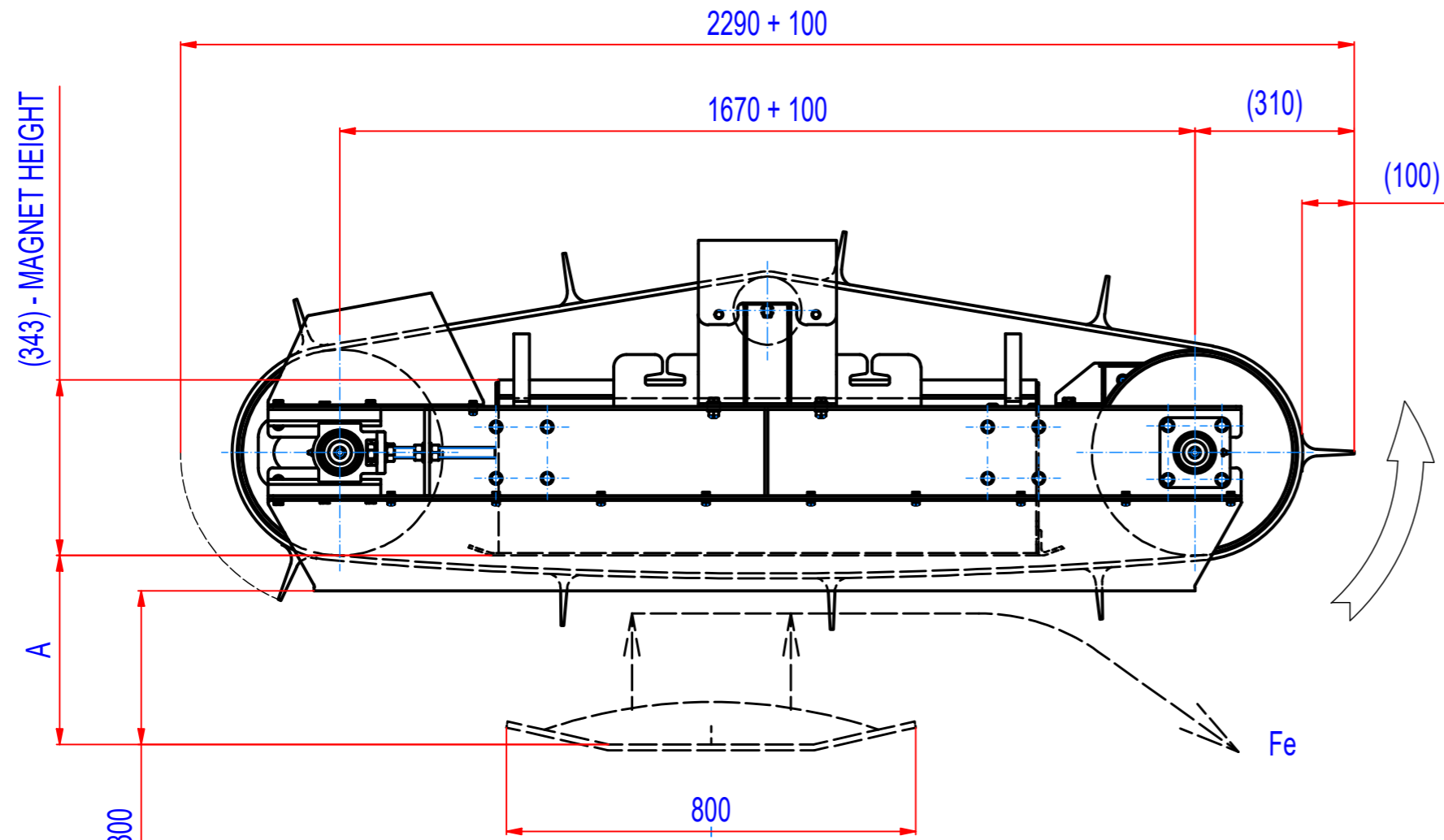

A = 430 mm - max. catch distance for rod Ø15, L=75 mm (VDE)
A = 370 mm - 400 Gs

- GEARED BOX SEW SA67/TDRN100L4, i=20,37 (71RPM),
MOTOR 230/400V, 3kW, 50Hz, IP55
- DRUM SPEED 71/min
- BELT SPEED 1,5m/s
- BELT EP500/4 5+2, LENGTH 4650, WIDTH 1000,
9 CLEATS T100/10, WIDTH 900

Sheet: A2	Extra info:	General tolerance: ISO 2768 - cL
Drawn: EN	Weight (kg): 1936,9 kg	Drawn according: ISO268; ISO1101; ISO2553
Date: 12.4.2018		Status:
Predecessor: SEPB080035		Customer reference number:
Quick search: XSPB 5	© All rights reserved. Reproduction is not permitted without written permission of GOUDSMIT Magnetic Systems BV	Product key: ROP-F5-C-080-W-G-L-B-B-NA
Description: Overband separator, Ferrite, Size 5, W0800, Cross		Part number: ROFC080350
		Rev: B