

REV	BY	DATE	DESCRIPTION
	EN	11.05.2017	ORIGINAL DRAWING
A	LF	28.06.2022	BELT CLEATS 50mm (WAS 100), MOTOR IP55 (WAS IP54) 13.03.2023 - REDUCTION IN THE NUMBER OF SPARE PARTS

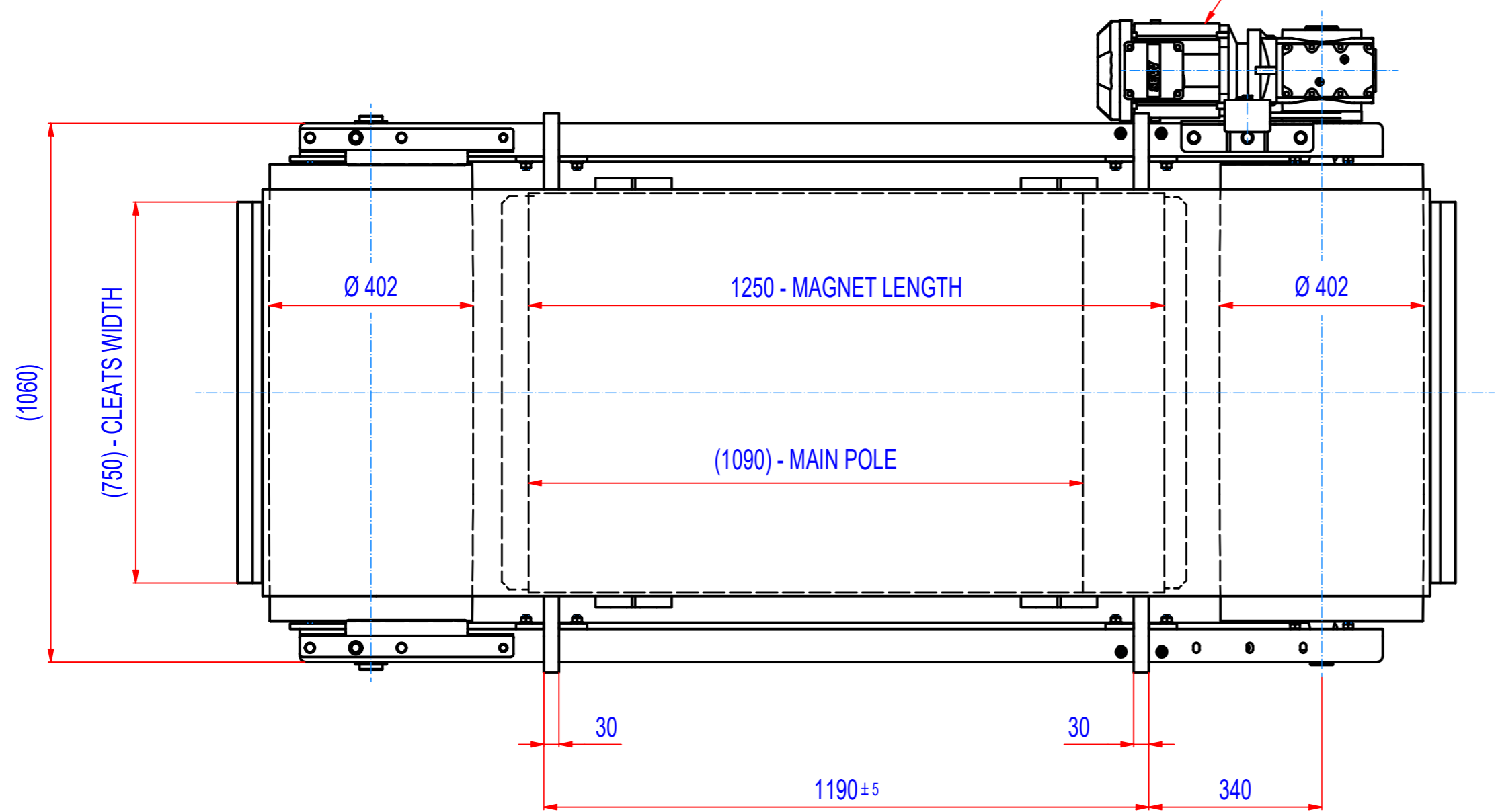
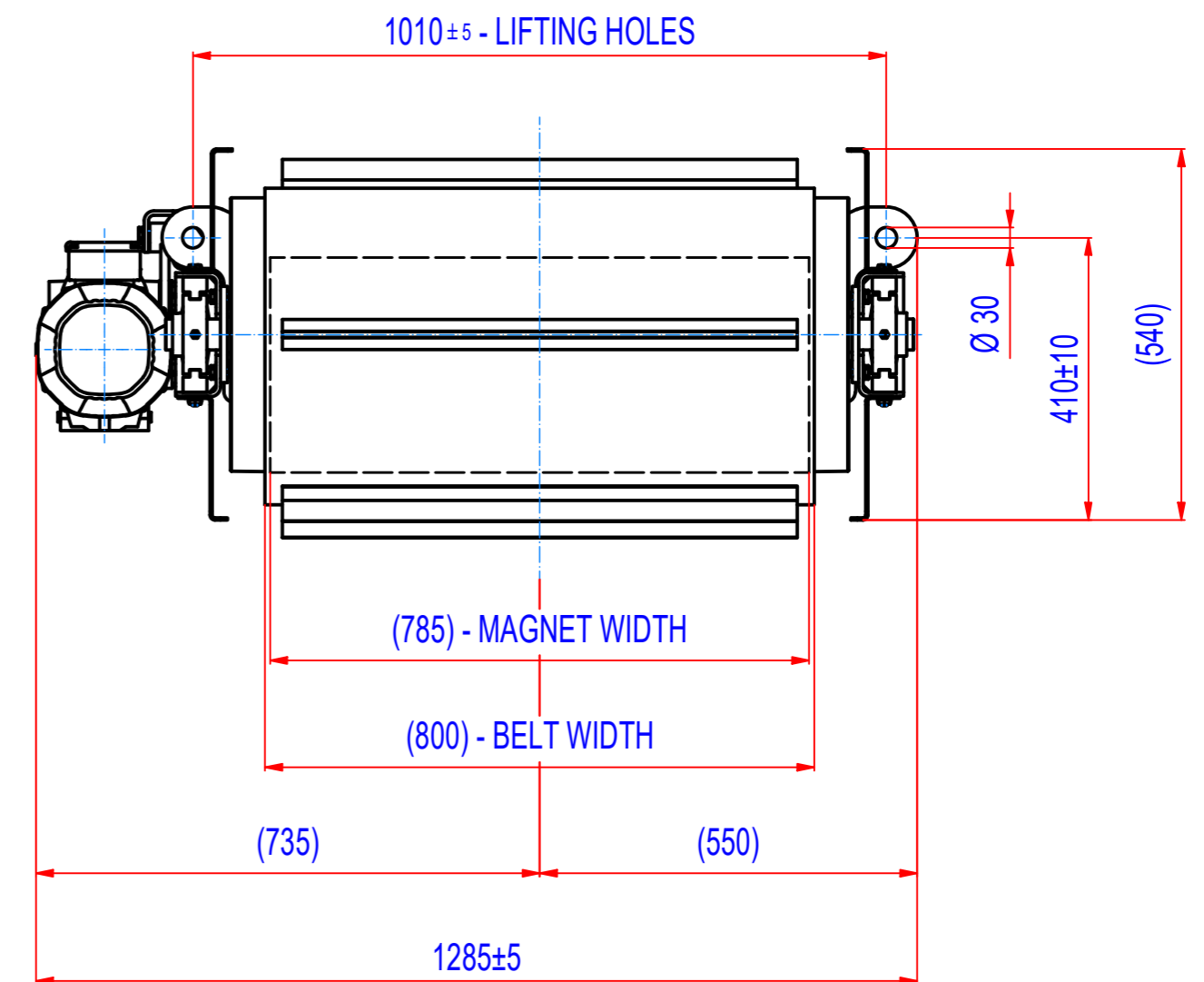
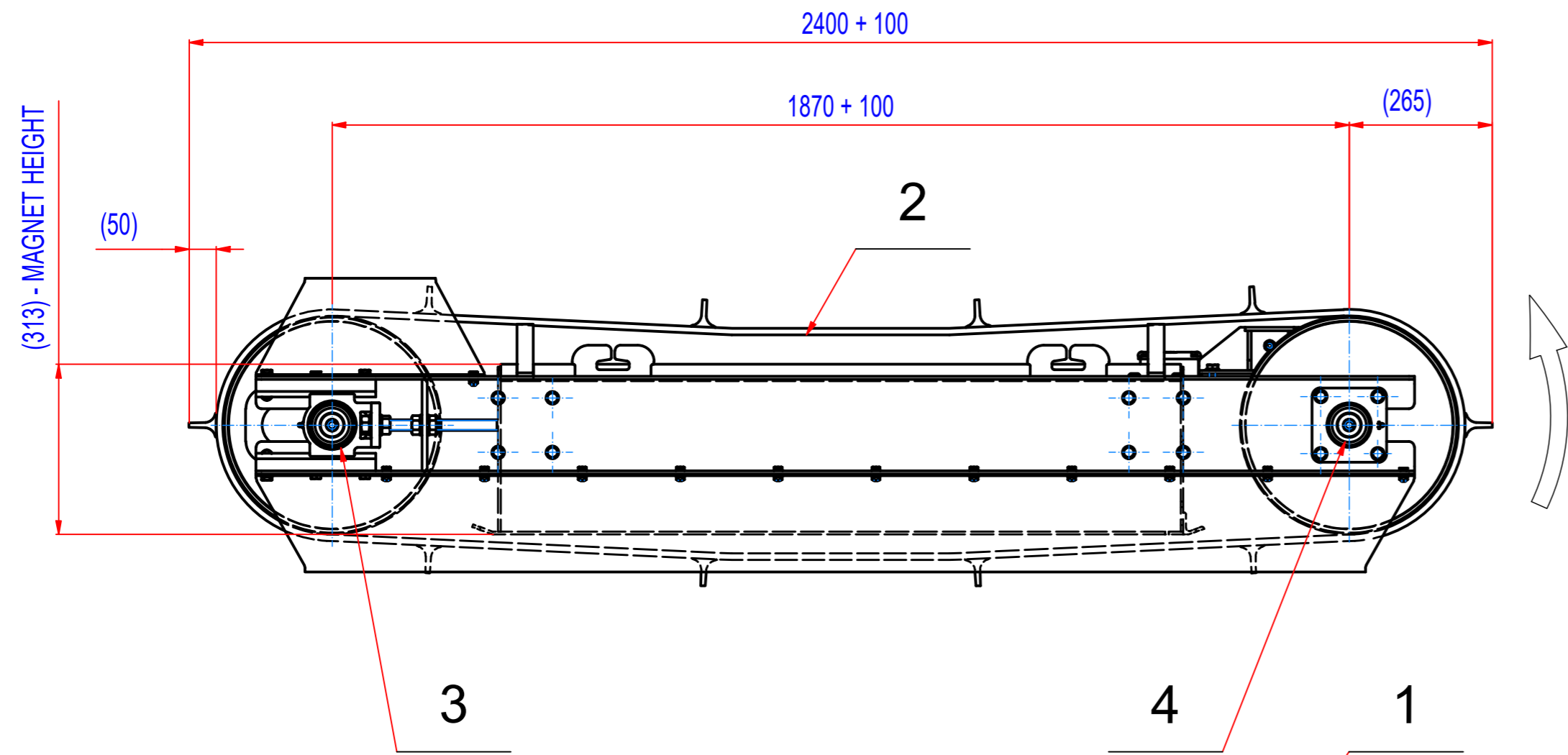

- GEARED BOX SEW SA67/TDRN100LS4, i=20,37 (71RPM),
MOTOR 230/400V, 2,2kW, 50Hz, IP55
- DRUM SPEED 71/min
- BELT SPEED 1,5m/s
- BELT EP500/4 5+2, LENGTH 5050, WIDTH 800,
10 CLEATS T50/10, WIDTH 750

POZ.	Č. SOUČÁSTI	POPIS	MATERIÁL	HMOT. MN.
4	15_8700045	BEARINGS ASSEMBLY INA PCJ 45		2,5 2
3	15_8600045	BEARINGS ASSEMBLY INA PTUE 45		2,7 2
2	45_4080060	BELT EP 500/4 5+2, W=800, L=5050	RUBBER	59 1
1	M022007132	SEW SA67/TDRN100LS4, 2,2kW, i=20,37 (71RPM)		59,2 1

Sheet: A2 Drawn: EN Date: 11.5.2017 Predecessor: SEPB100034 Quick search: XSPB 4 Description: SPARE PARTS FOR ROFC100340	Extra info: <small>© All rights reserved. Reproduction is not permitted without written permission of GOUDSMIT Magnetic Systems BV</small>	General tolerance: ISO 2768 - cL Drawn according: ISO268; ISO1101; ISO2553 Status: Customer reference number: Product key: ROP-F4-C-100-W-G-L-B-B-NA Part number: ROFC100340_SP Rev: A
---	---	---