

REV	DATE	BY	DESCRIPTION
-	26.07.2017	LF	ORIGINAL DRAWING
A	25.11.2021	PW	MOTOR IP55 (WAS IP54)
			21.03.2023 - REDUCTION IN THE NUMBER OF SPARE PARTS

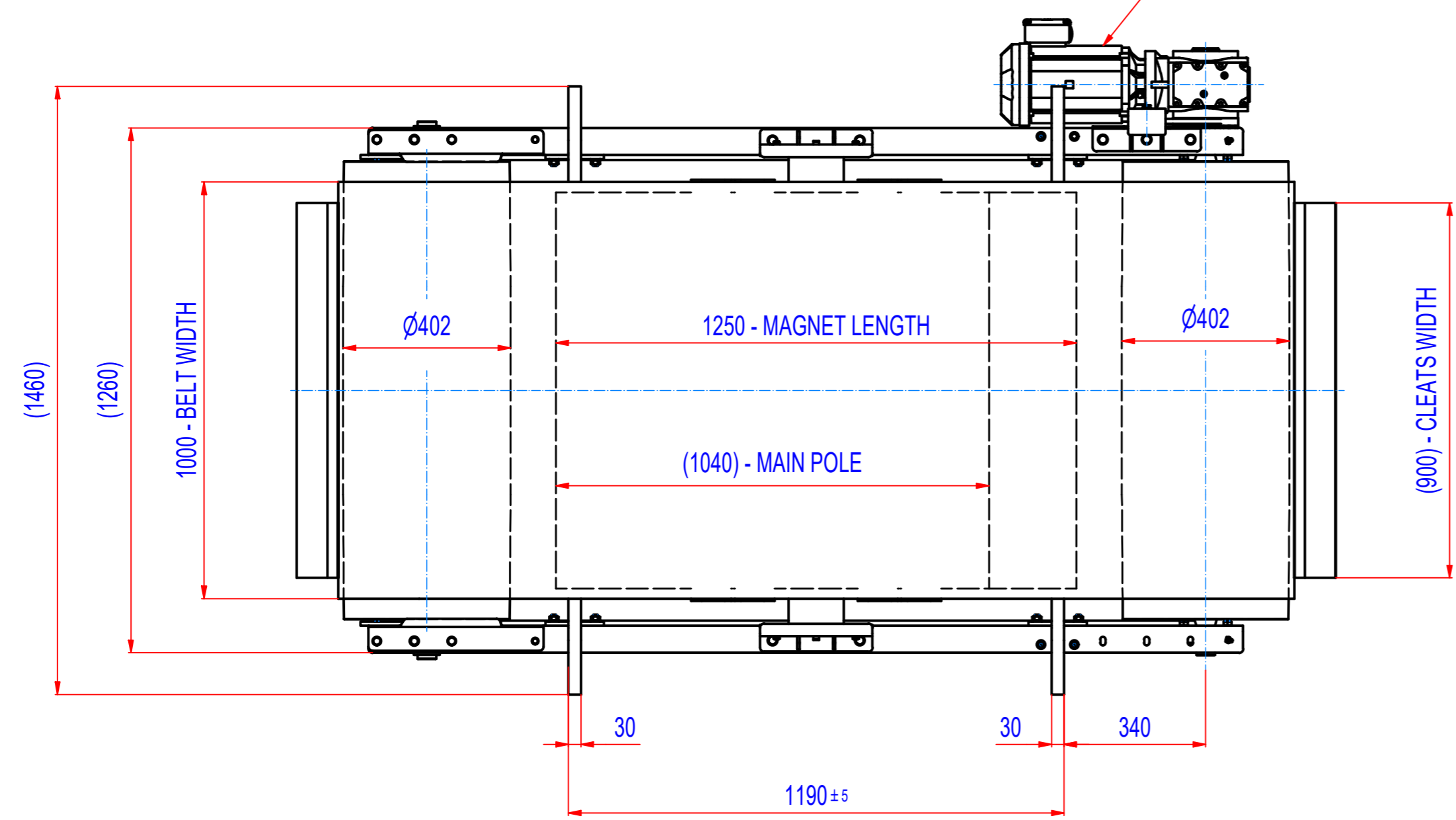
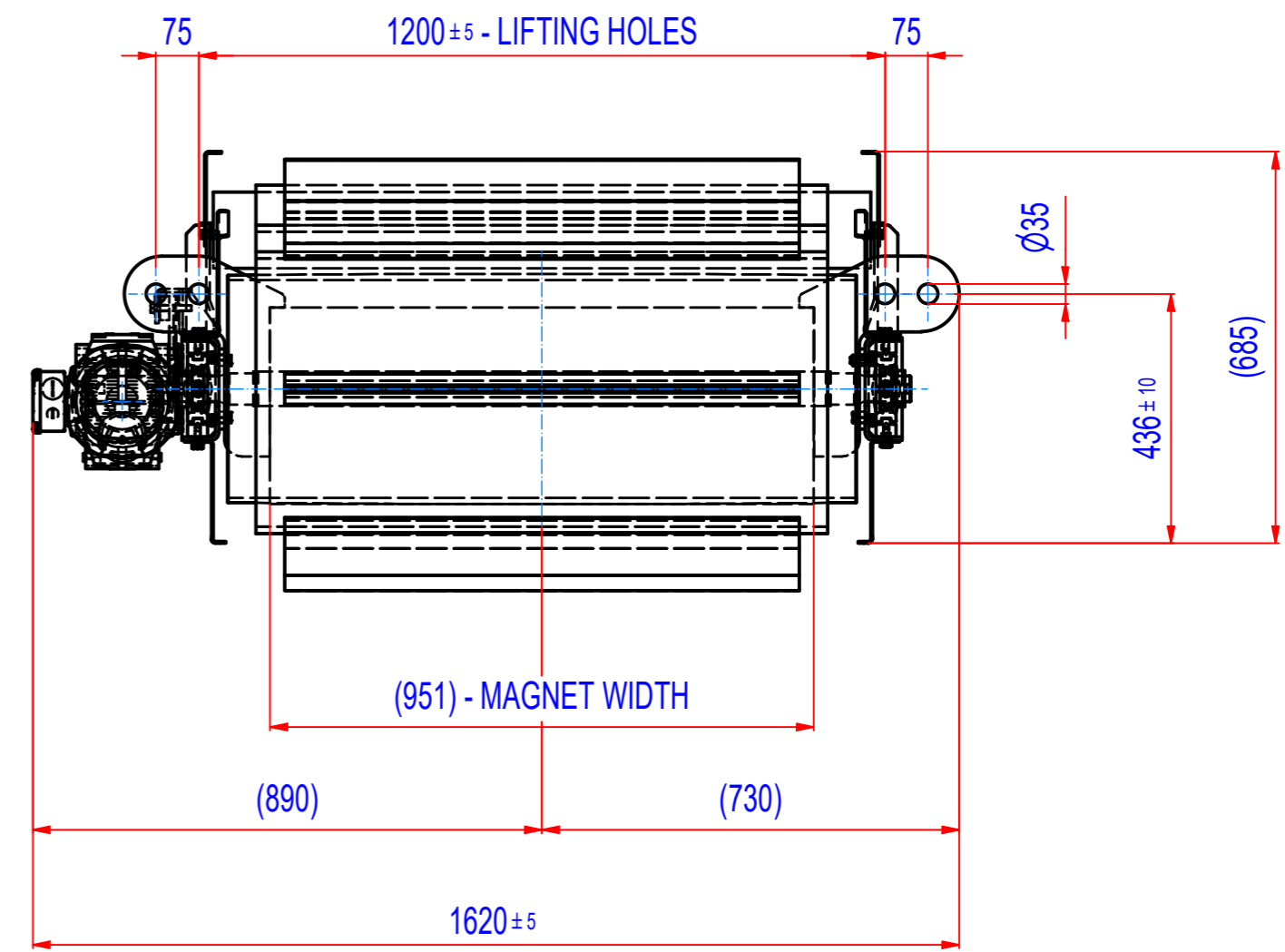
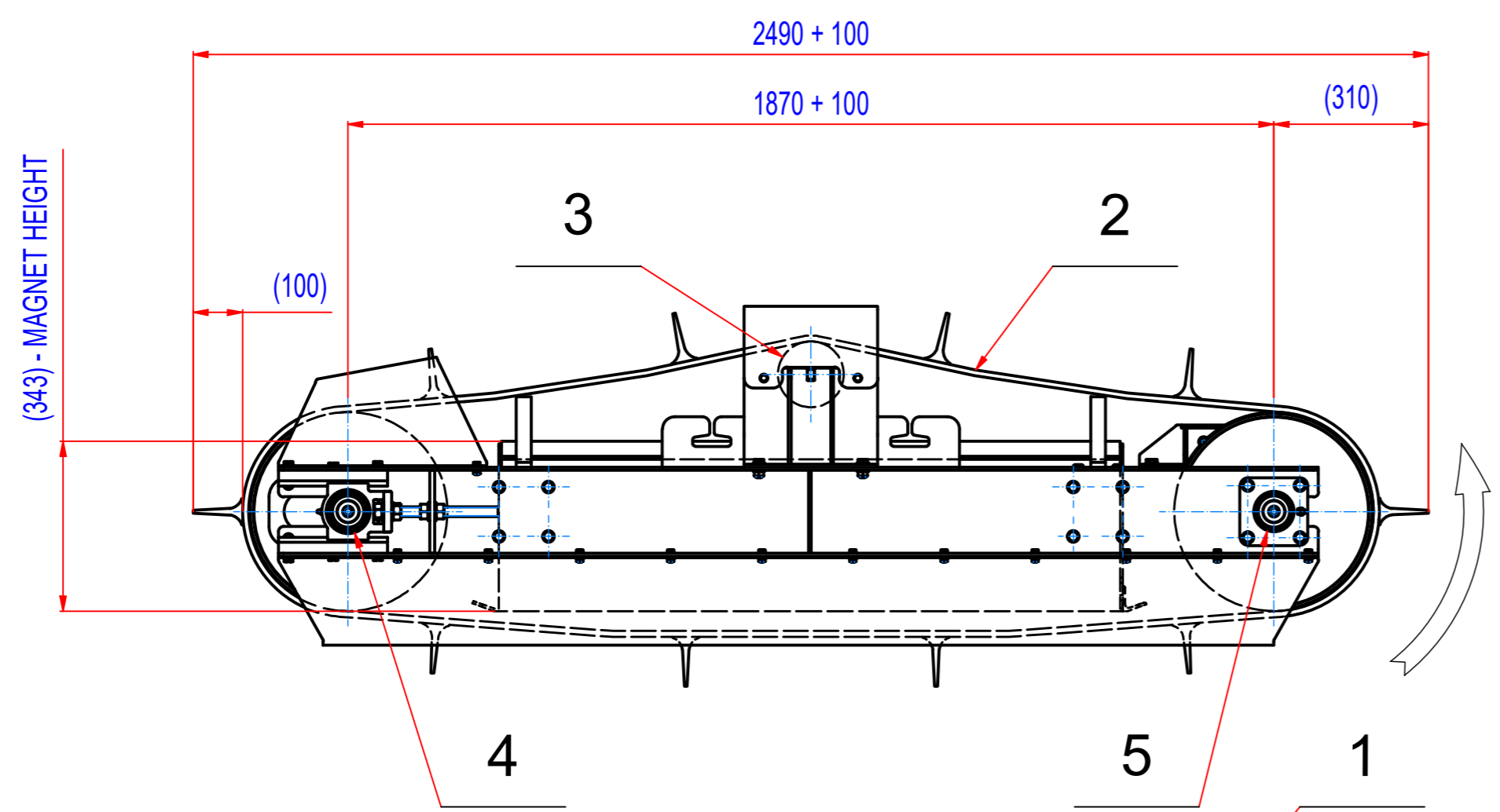

- GEARED BOX SEW SA67/TDRN100L4, i=20,37 (71RPM),  
MOTOR 230/400V, 3kW, 50Hz, IP55  
- DRUM SPEED 71/min  
- BELT SPEED 1,5m/s  
- BELT EP500/4 5+2, LENGTH 5080, WIDTH 1000,  
10 CLEATS T100/10, WIDTH 900

POZ.	Č. SOUČÁSTI	POPIS	MATERIÁL	HMOT.	MN.
5	15_8700045	BEARINGS ASSEMBLY INA PCJ 45		2,5	2
4	15_8600045	BEARINGS ASSEMBLY INA PTUE 45		2,7	2
3	1510_00009	PLAIN ROLLER 133x1150/6306		23,9	1
2	45_4100017	BELT EP500/4 5+2, W=1000, L=5080	RUBBER	85	1
1	MO30007116	SEW SA67/TDRN100L4, 3kW, i=20,37 (71 RPM)		64	1

Sheet: A2 Drawn: LF Date: 25.11.2021 Predecessor: SEPB100035 Quick search: XSPB 5 Description: SPARE PARTS FOR ROFC100350	Weight (kg): 2255.5  © All rights reserved. Reproduction is not permitted without written permission of GOUDSMIT Magnetic Systems BV	General tolerance: ISO 2768 - cL Drawn according: ISO268; ISO1101; ISO2553 Status: Customer reference number: Product key: ROP-F5-C-100-W-G-L-B-B-NA Part number: ROFC100350_SP Rev: -
--	--	--