

REV	BY	DATE	DESCRIPTION
-	LF	15.05.2019	ORIGINAL DRAWING
			24.03.2023 - REDUCTION IN THE NUMBER OF SPARE PARTS

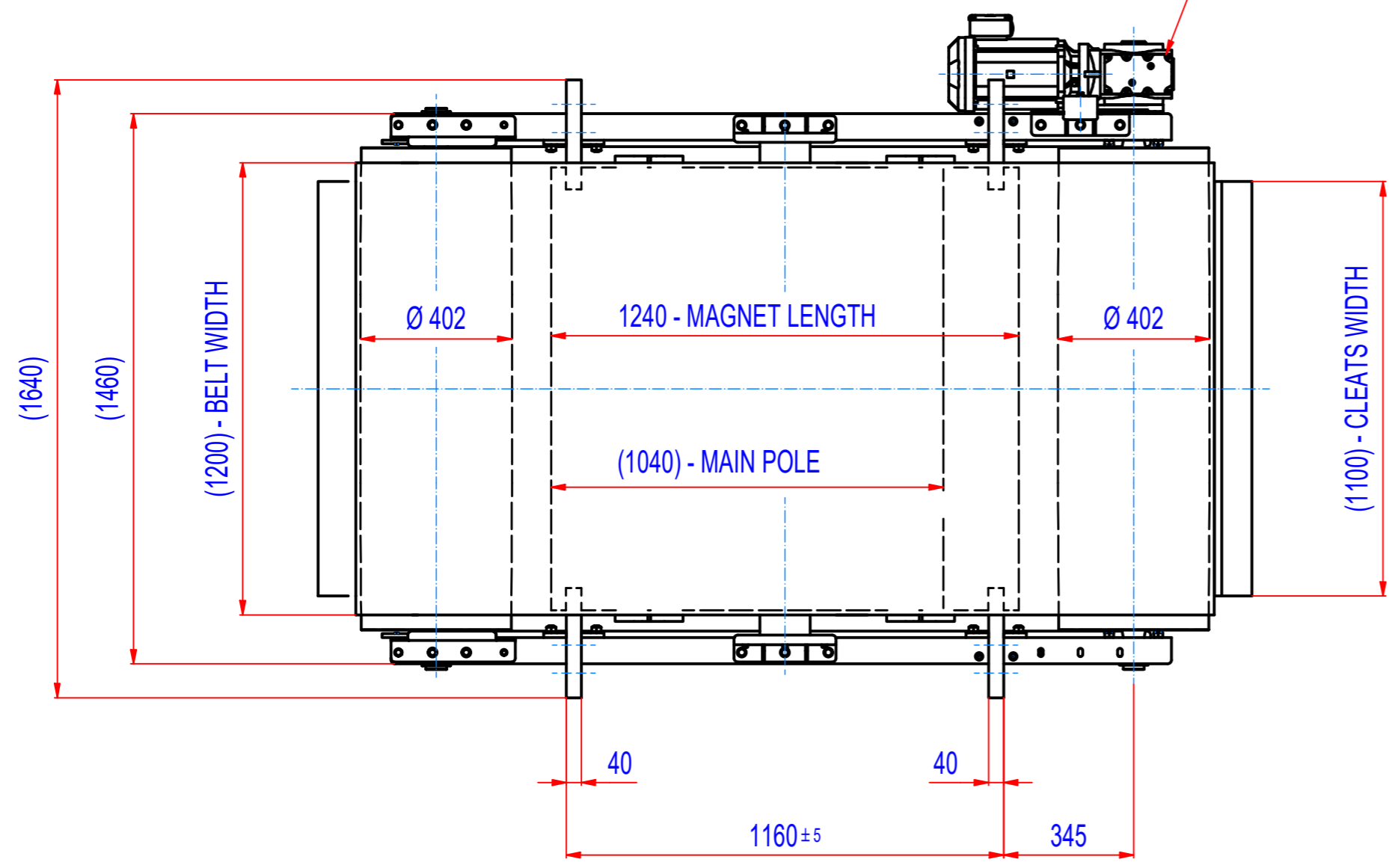
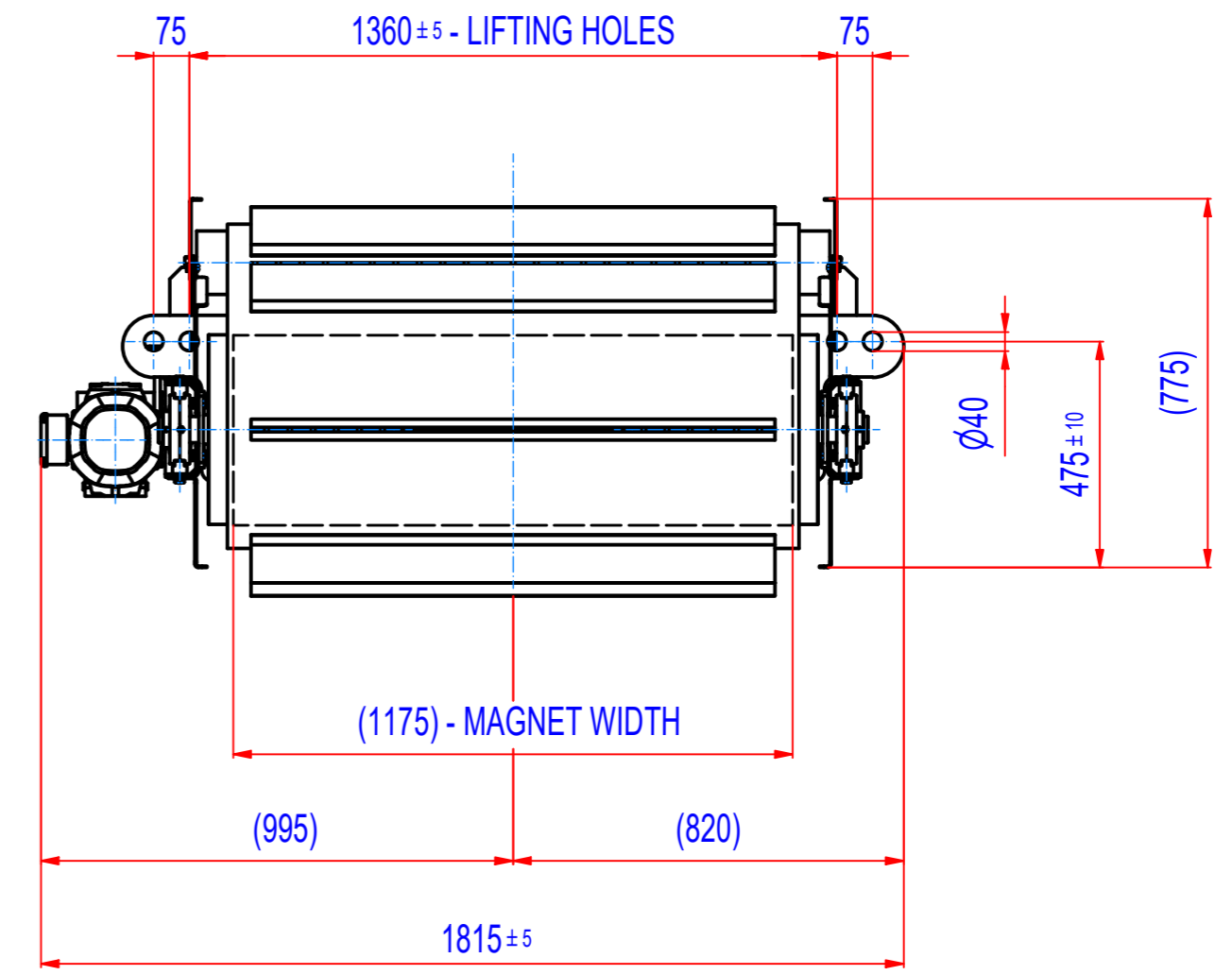
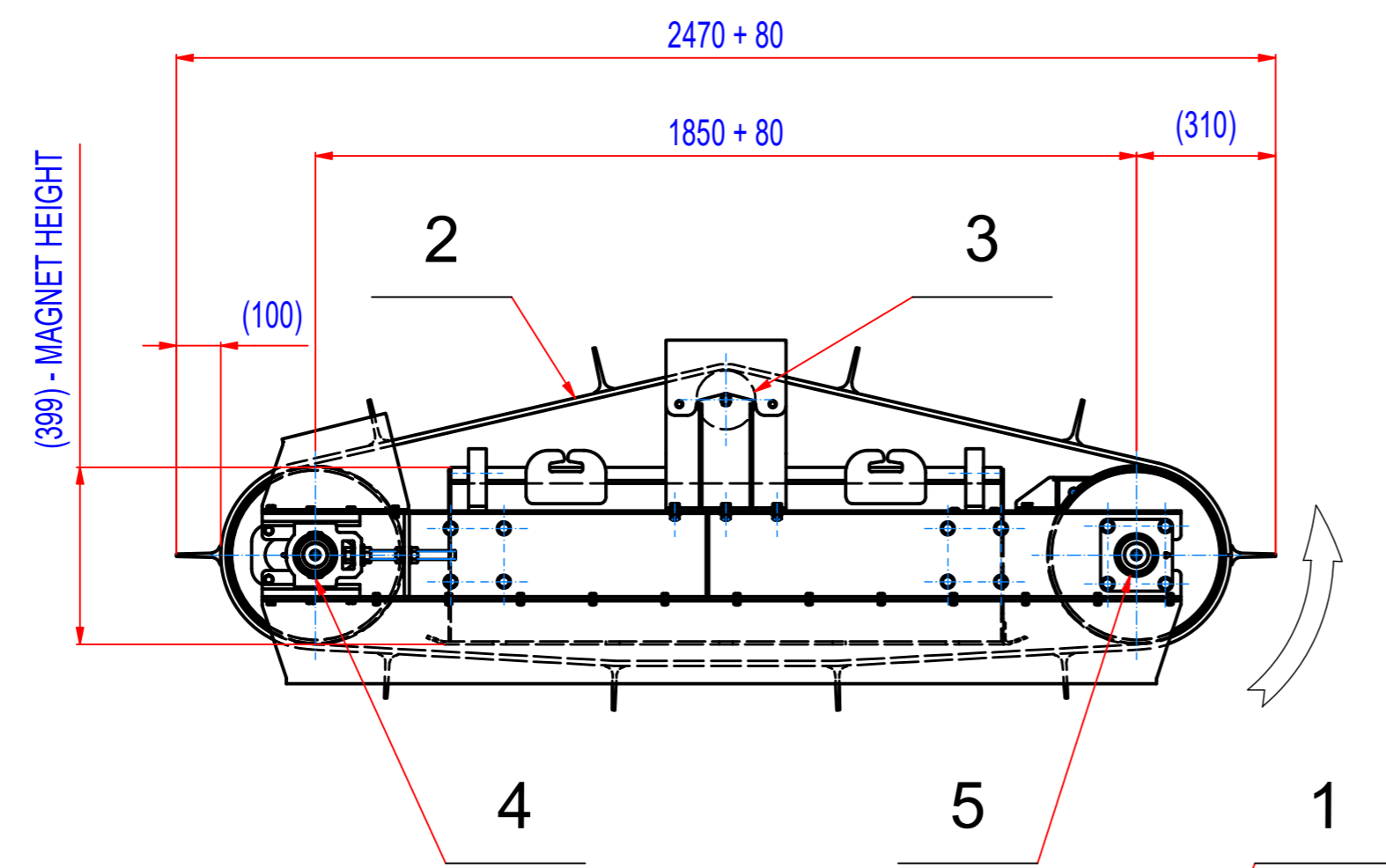

- GEARED BOX SEW SA67/T DRN100L4, i=20,37 (71RPM),  
 MOTOR 230/400V, 3kW, 50Hz, IP55  
 - DRUM SPEED 71/min  
 - BELT SPEED 1,5 m/s  
 - BELT EP500, LENGTH 5070, WIDTH 1200,  
 10 CLEATS T100/10, WIDTH 1100

POZ.	Č. SOUČÁSTI	POPIS	MATERIÁL	HMOT.	MN.
5	15_8700055	BEARINGS ASSEMBLY INA PCJ 55		3,5	2
4	15_8600057	BEARINGS ASSEMBLY INA PTUE 55		4	2
3	1510_00053	PLAIN ROLLER d=133, L=1330		27	1
2	45_4120018	BELT EP500/4 5+2, W=1200, L=5070	RUBBER	107	1
1	MO30007116	SEW SA67/TDRN100L4, 3kW, 9=20,7 (71 RPM)		64	1

Sheet: <b>A2</b> Drawn: <b>LF</b> Date: <b>15.5.2019</b> Predecessor: <b>SEPB100036</b> Quick search: <b>XSPB 6</b> Description: <b>SPARE PARTS FOR ROFC100360</b>	Extra info:  © All rights reserved. Reproduction is not permitted without written permission of GOUDSMIT Magnetic Systems BV	General tolerance: <b>ISO 2768 - cL</b> Drawn according: <b>ISO268; ISO1101; ISO2553</b> Status: Customer reference number: Product key: <b>ROP-F6-C-100-W-G-L-B-B-NA</b> Part number: <b>ROFC100360_SP</b> Rev: -
---	--	--