

REV	DATE	BY	DESCRIPTION
-	02.04.2019	PW	NEW VAULT, OLD REF. ROFC120330_SP_A
			06.03.2023 - REDUCTION IN THE NUMBER OF SPARE PARTS

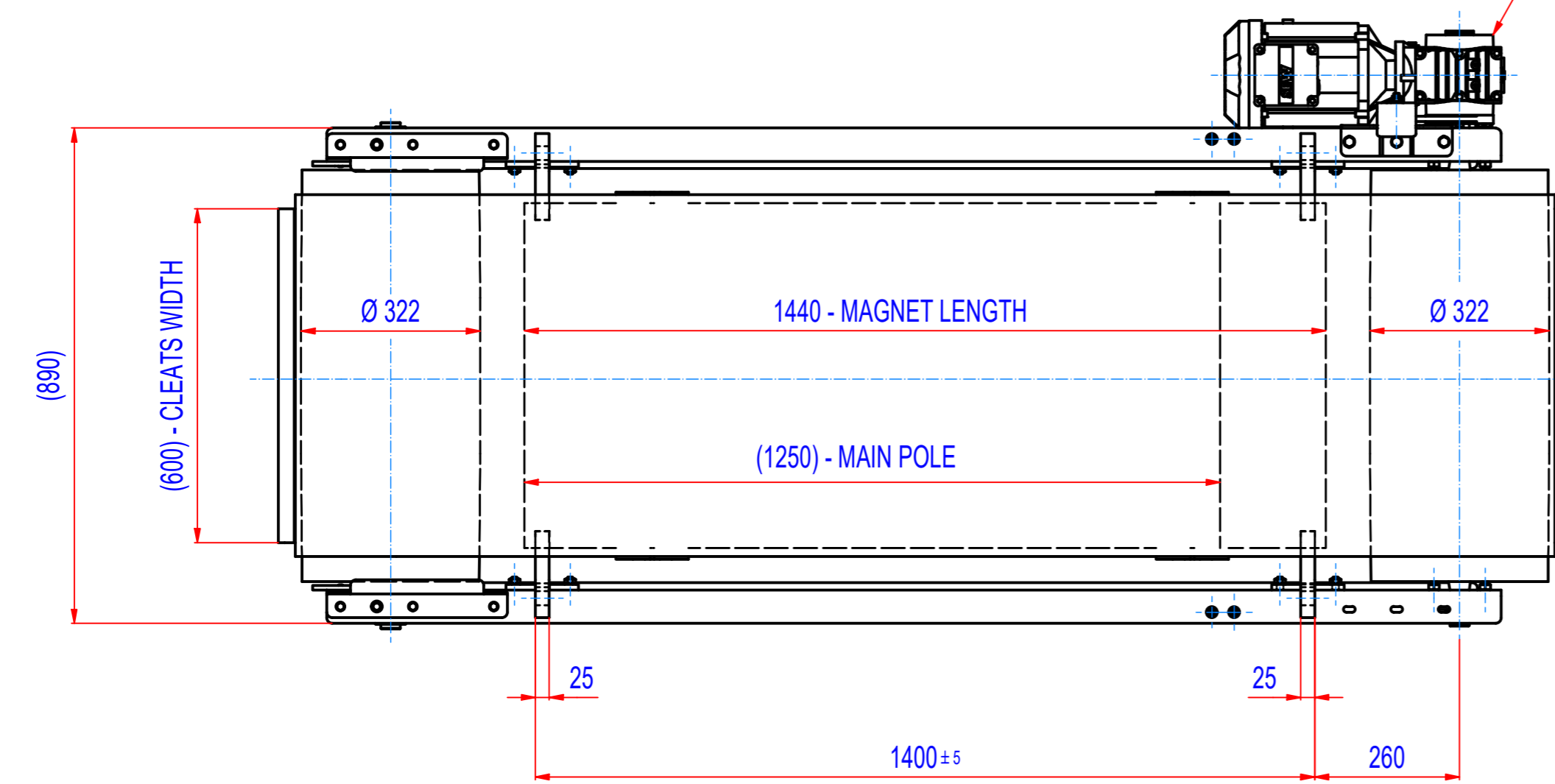
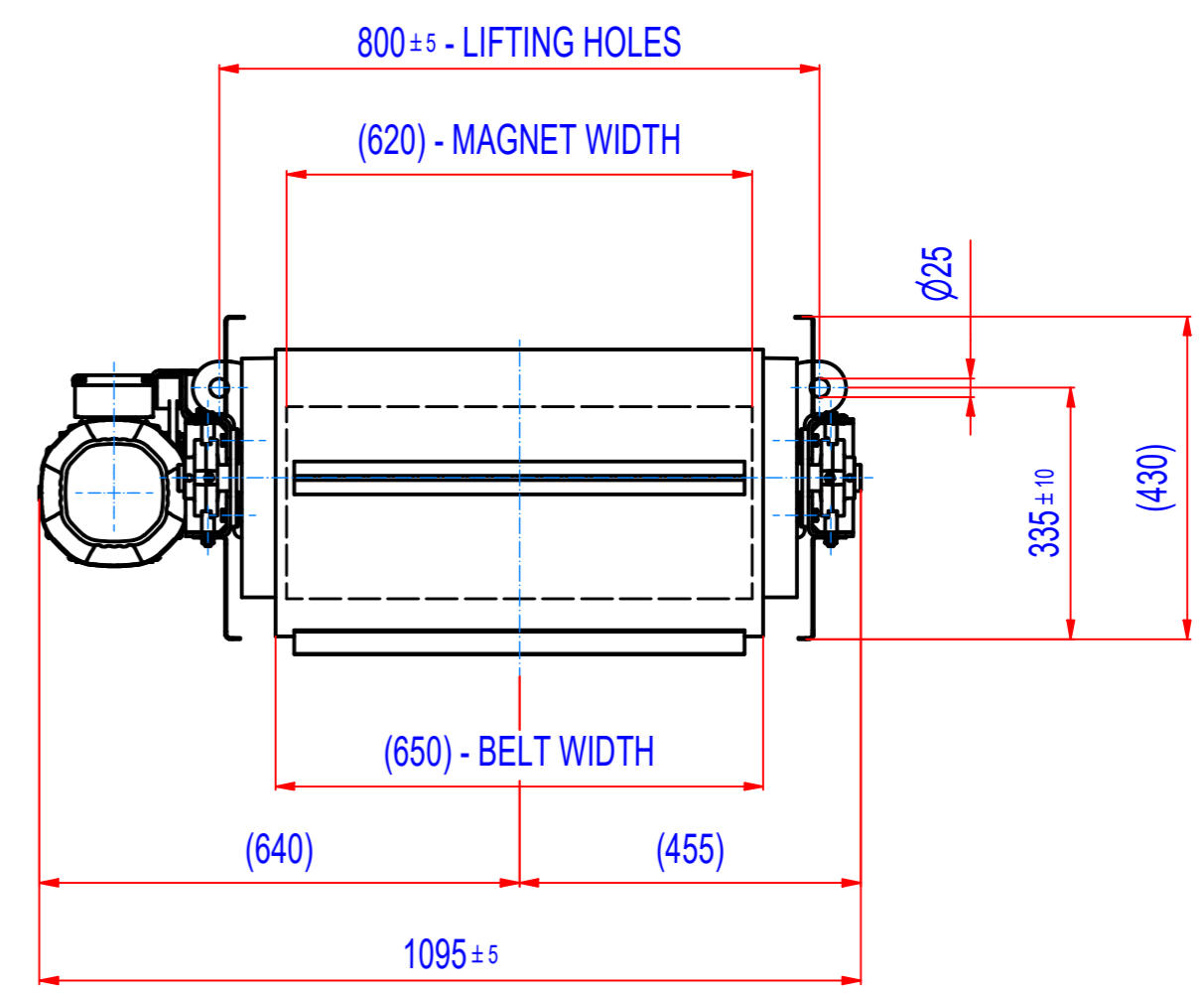
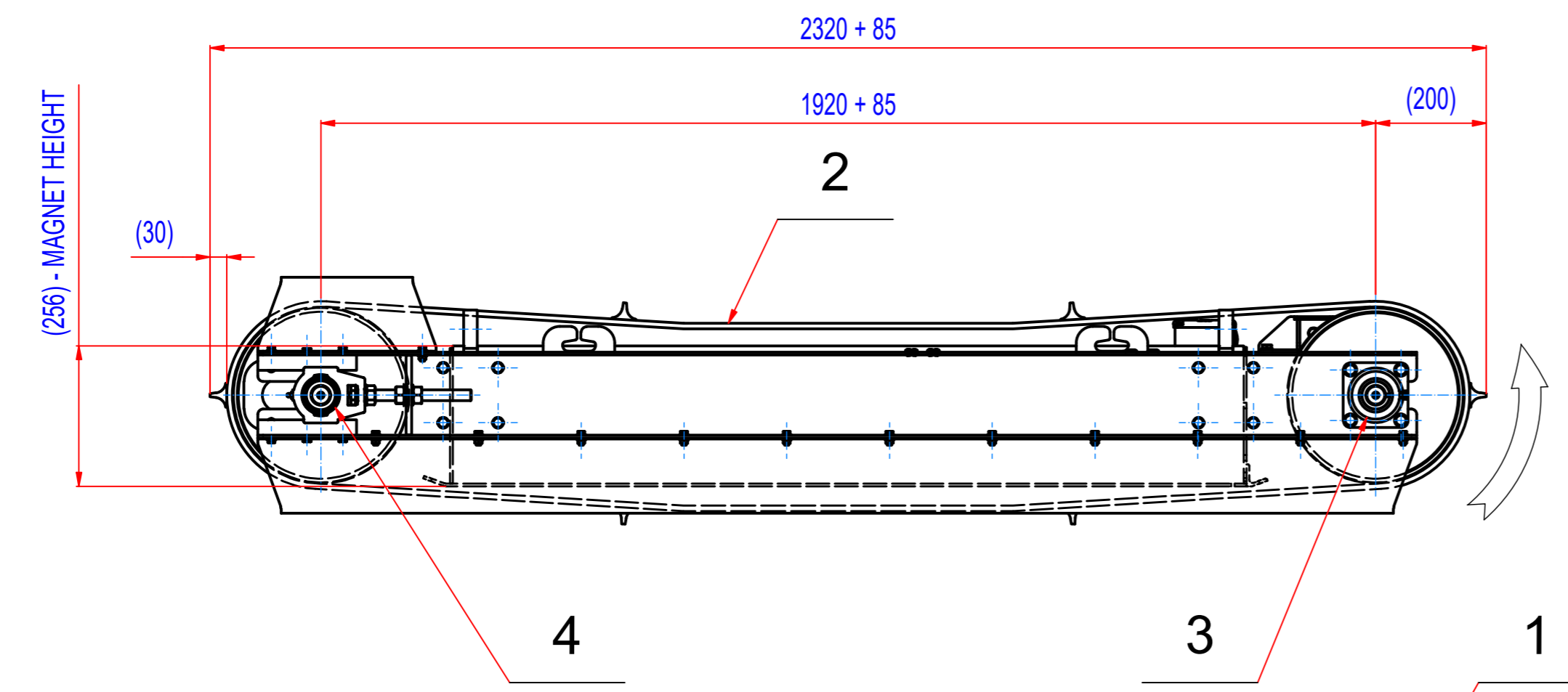

- GEARED BOX SEW SA57/TDRN100LS4, i=14,24 (102RPM), MOTOR 230/400V, 2,2kW, 50Hz, IP55  
 - DRUM SPEED 102/min  
 - BELT SPEED 1,7 m/s  
 - BELT EB400/3 4+2, WIDTH 650, LENGTH 4900, 6 CLEATS T30/10, WIDTH 600

POZ.	Č. SOUČÁSTI	POPIS	MATERIÁL	HMOT.	MN.
4	15_8600035	BEARINGS ASSEMBLY INA PTUE 35		1,7	2
3	15_8700035	BEARINGS ASSEMBLY INA PCJ 35		1,5	2
2	45_4065012	BELT EP 400/3 4+2, W=650, L=4900	RUBBER	38	1
1	M022010003	SEW SA57/TDRN100LS4, 2,2kW, i=14,24 (102RPM)		42	1

Sheet: A2 Drawn: PW Date: 2.4.2019 Predecessor: SEPB120033 Quick search: XSPB 3 Description: SPARE PARTS FOR ROFC120330	Weight (kg): 1156,4  <small>© All rights reserved. Reproduction is not permitted without written permission of GOUDSMIT Magnetic Systems BV</small>	Extra info: General tolerance: ISO 2768 - cL Drawn according: ISO268; ISO1101; ISO2553 Status: Customer reference number: Product key: ROP-F3-C-120-W-G-L-B-B-NA Part number: ROFC120330_SP Rev: -
--	---	---