

REV	DATE	BY	DESCRIPTION
-	02.01.2018	LF	ORIGINAL DRAWING
A	13.03.2023	LF	BELT CLEATS 50mm (WAS 100), MOTOR IP55 (WAS IP54)

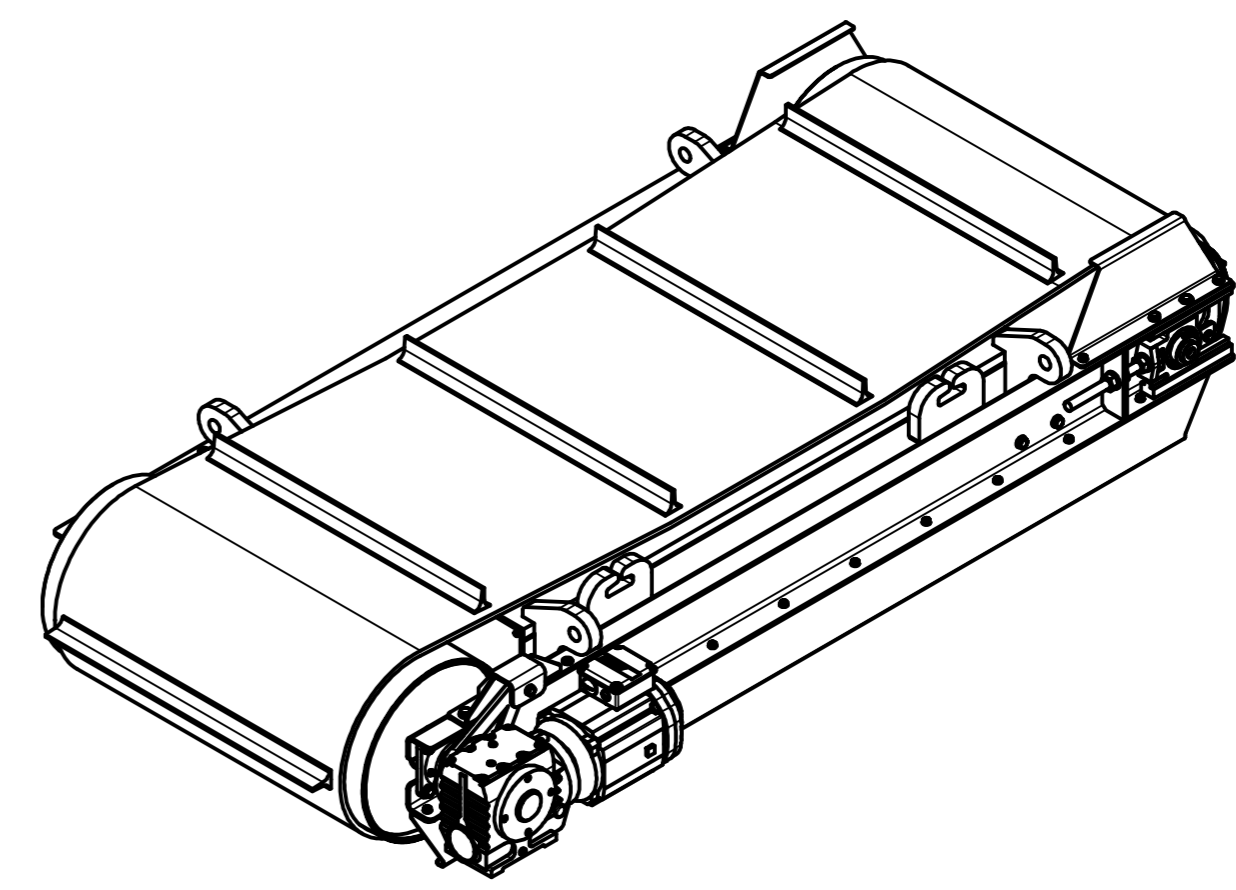
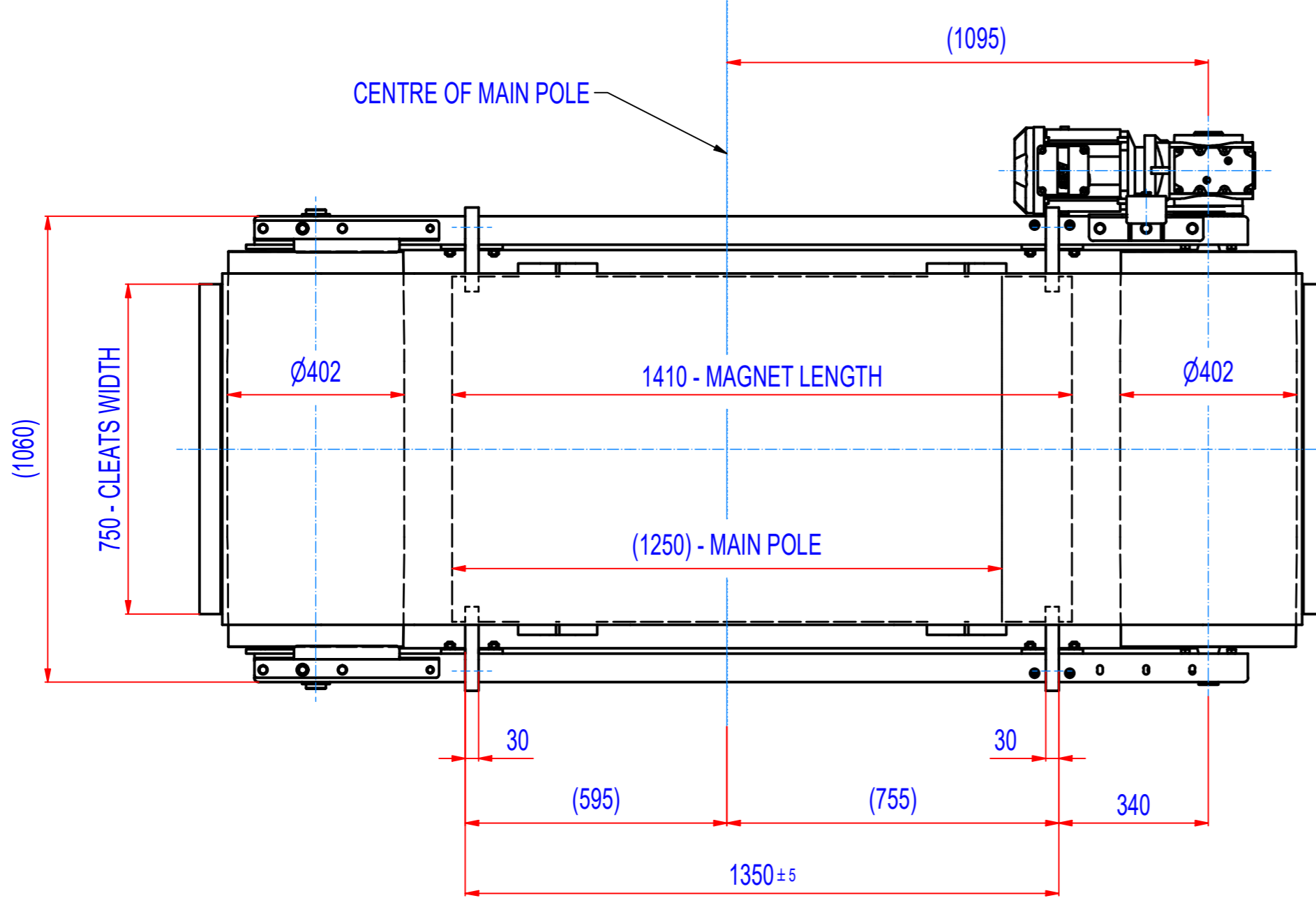
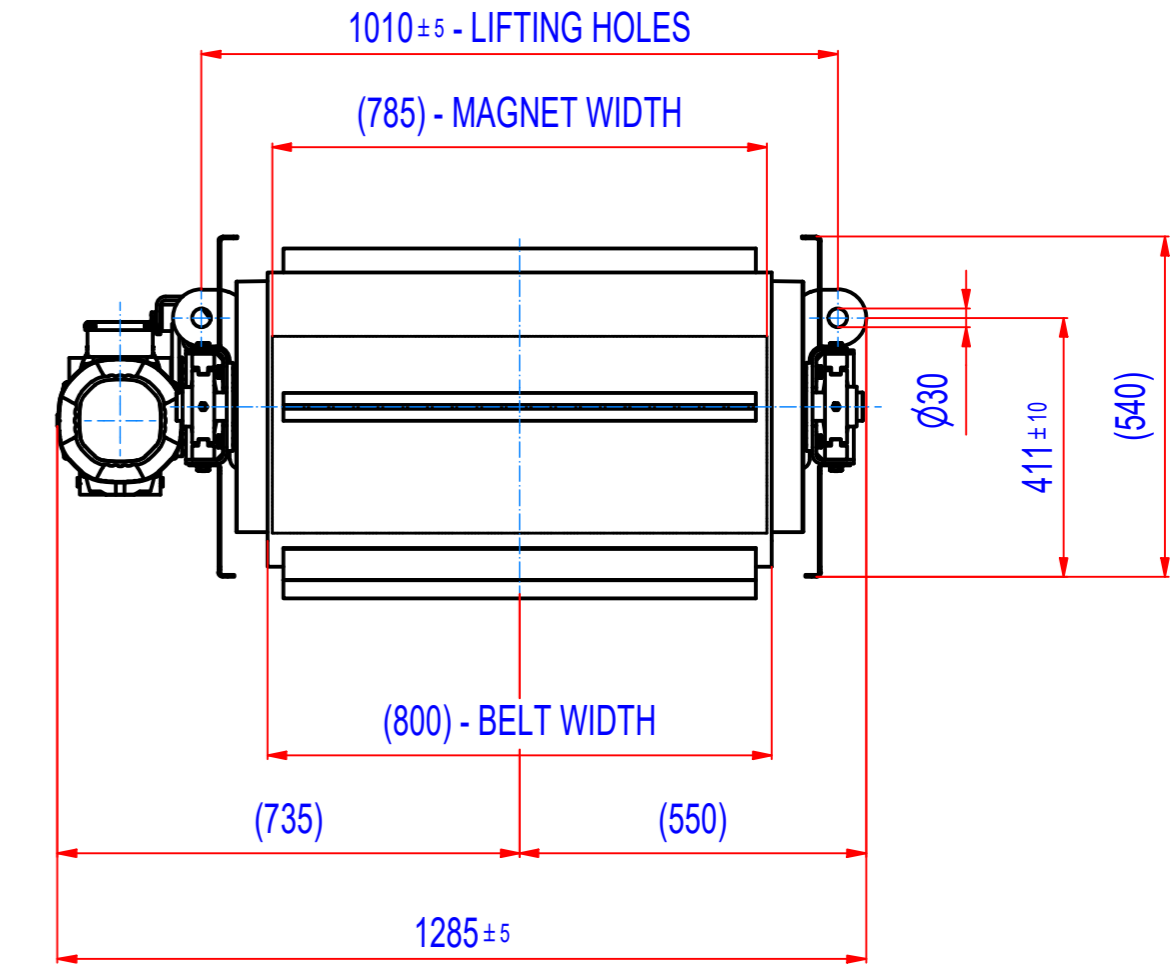
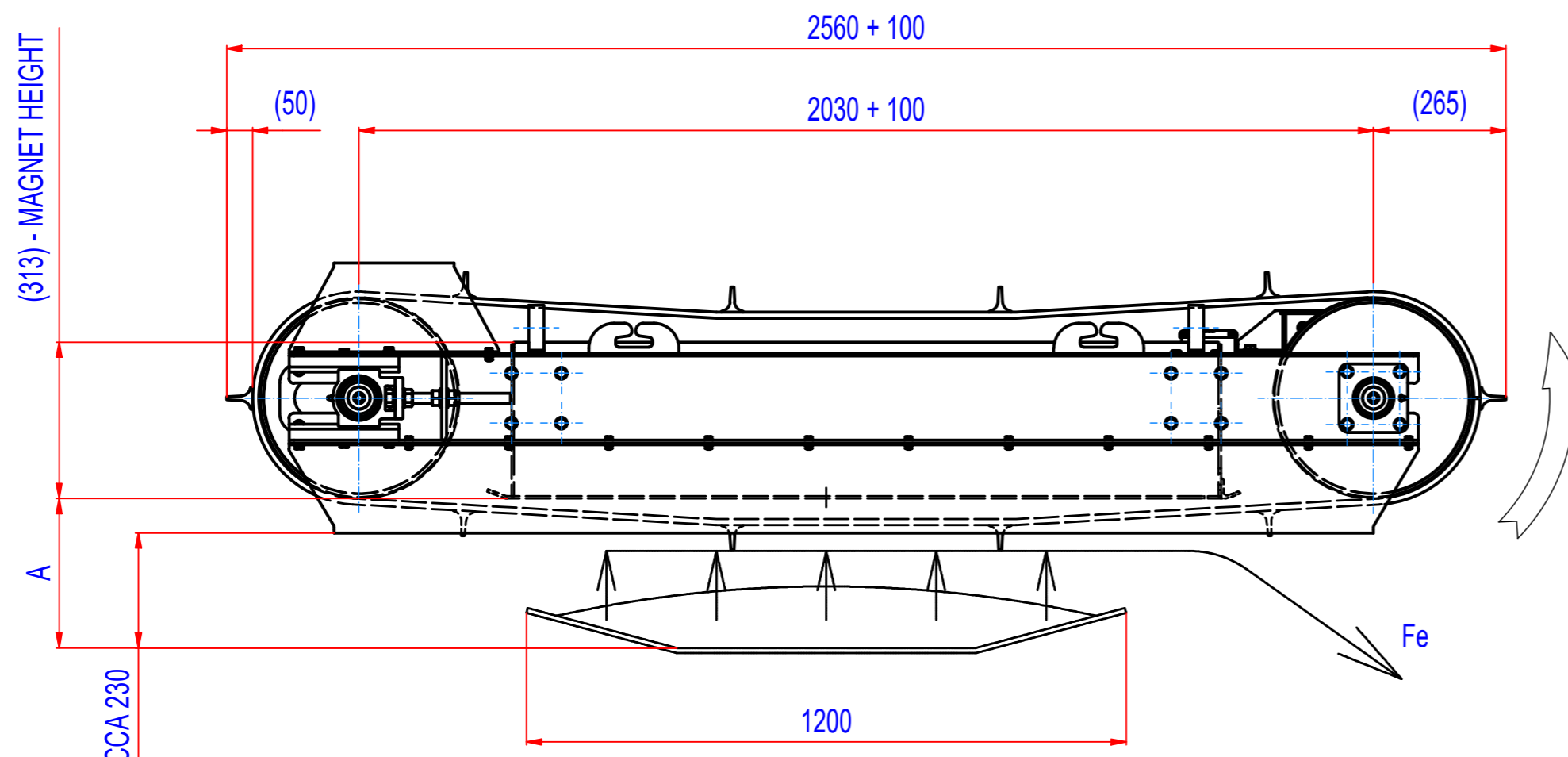

A = 380 mm - max. catch distance for rod Ø15, L=75 mm (VDE)
A = 300 mm - 400 Gs

- GEARED BOX SEW SA67/TDRN100LS4; i=20,37 (71RPM);
MOTOR 230/400V; 2,2kW; 50Hz; IP55
- ROLLER SPEED 71/min
- BELT SPEED 1,5m/s
- BELT EP500/4 5+2; LENGTH 5380, WIDTH 800,
10 CLEATS T50/10, WIDTH 750

Sheet: A2	Extra info:	General tolerance: ISO 2768 - cL
Drawn: LF	Weight (kg): 1880,5 kg	Drawn according: ISO268; ISO1101; ISO2553
Date: 2.1.2018		Status:
Predecessor: SEPB120034		Customer reference number:
Quick search: XSPB 4	© All rights reserved. Reproduction is not permitted without written permission of GOUDSMIT Magnetic Systems BV	Product key: ROP-F4-C-120-W-G-L-B-B-NA
Description: Overband magnet, Ferrite, Size 4, W1200, Cross		Part number: ROFC120340
		Rev: A