

REV	BY	DATE	DESCRIPTION
	PW	14.12.2017	New Vault, nothing changed
A	LF	26.03.2022	MOTOR IP55 (WAS IP54) 20.03.2023 - REDUCTION IN THE NUMBER OF SPARE PARTS

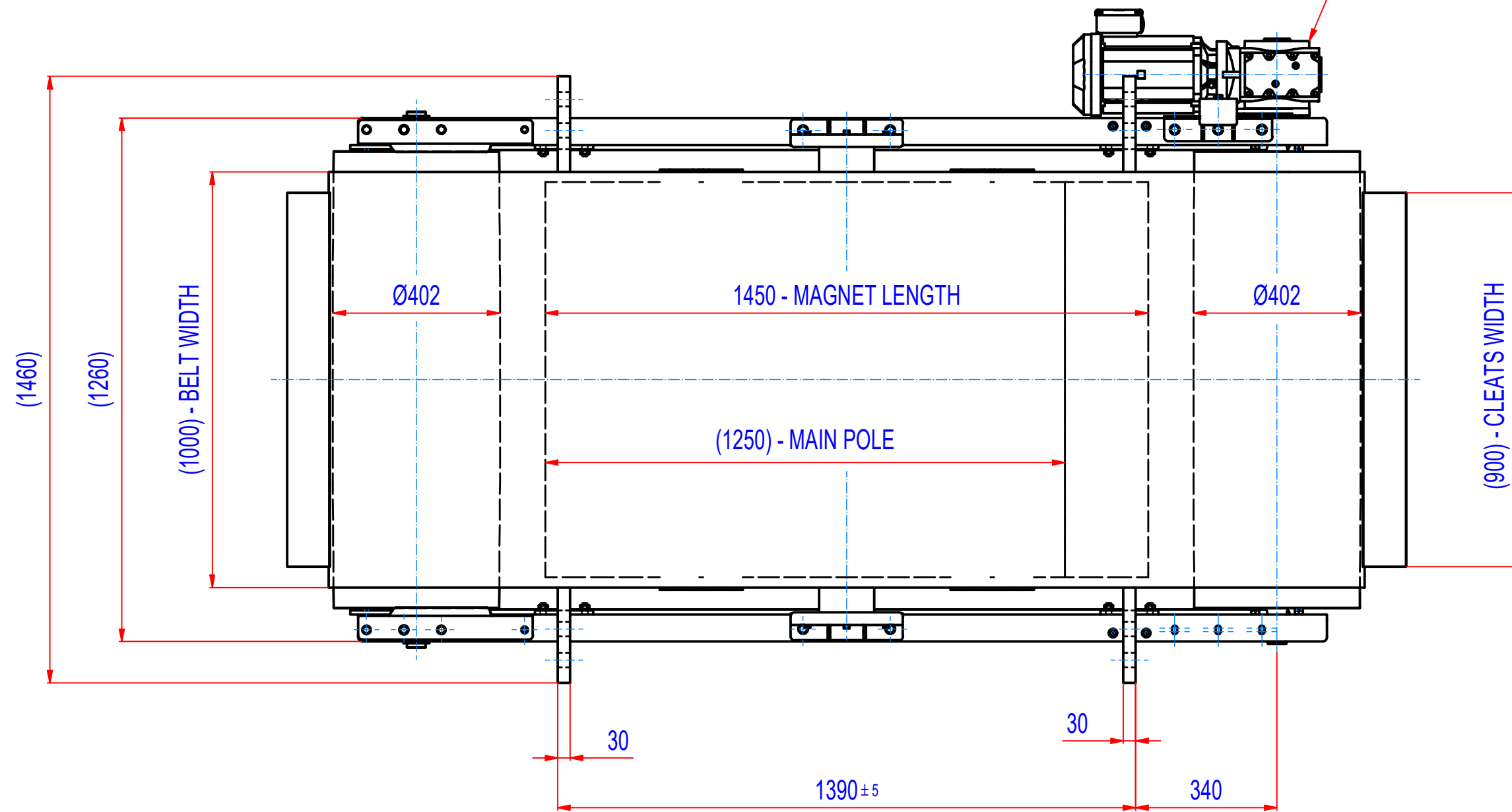
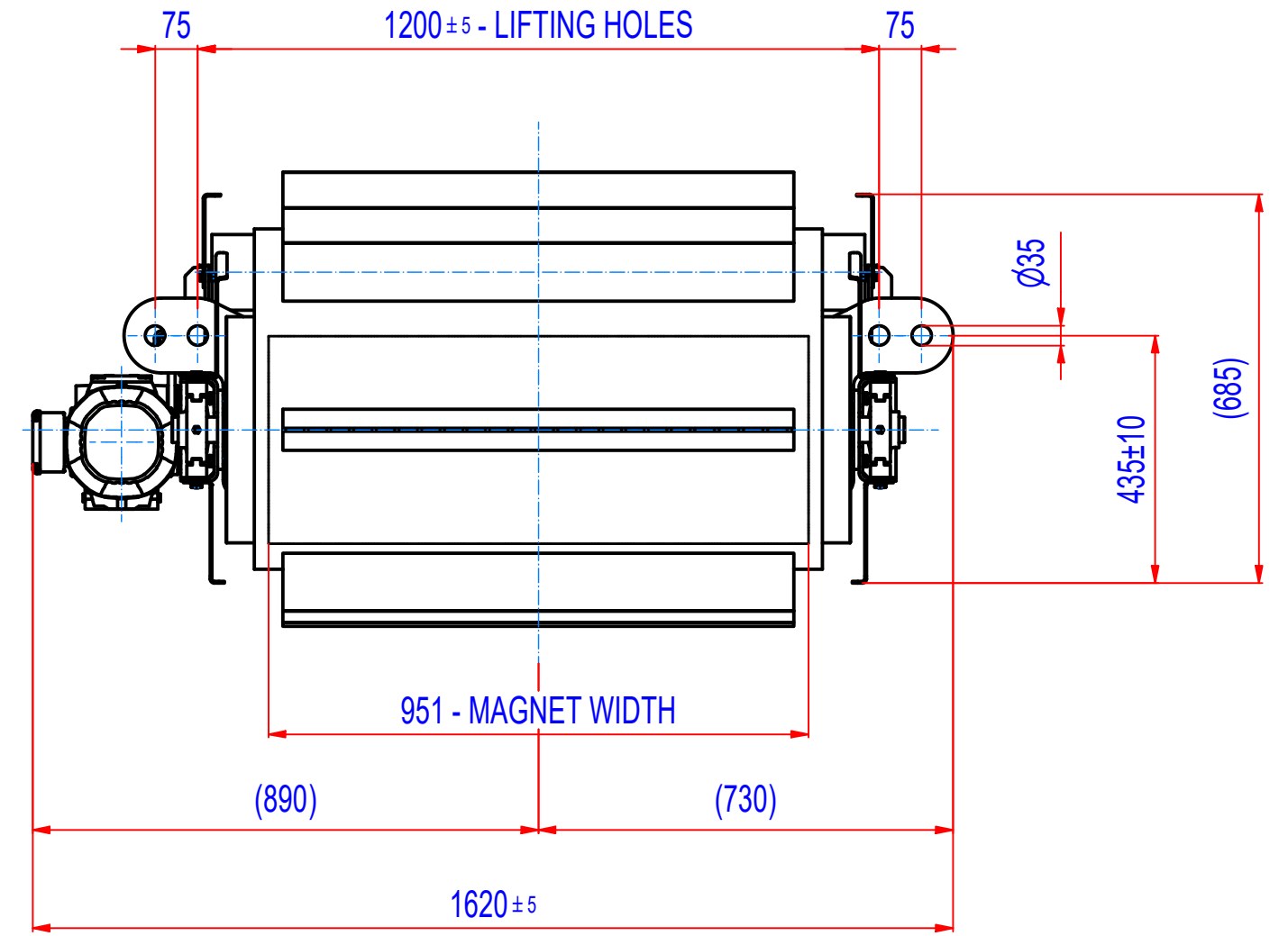
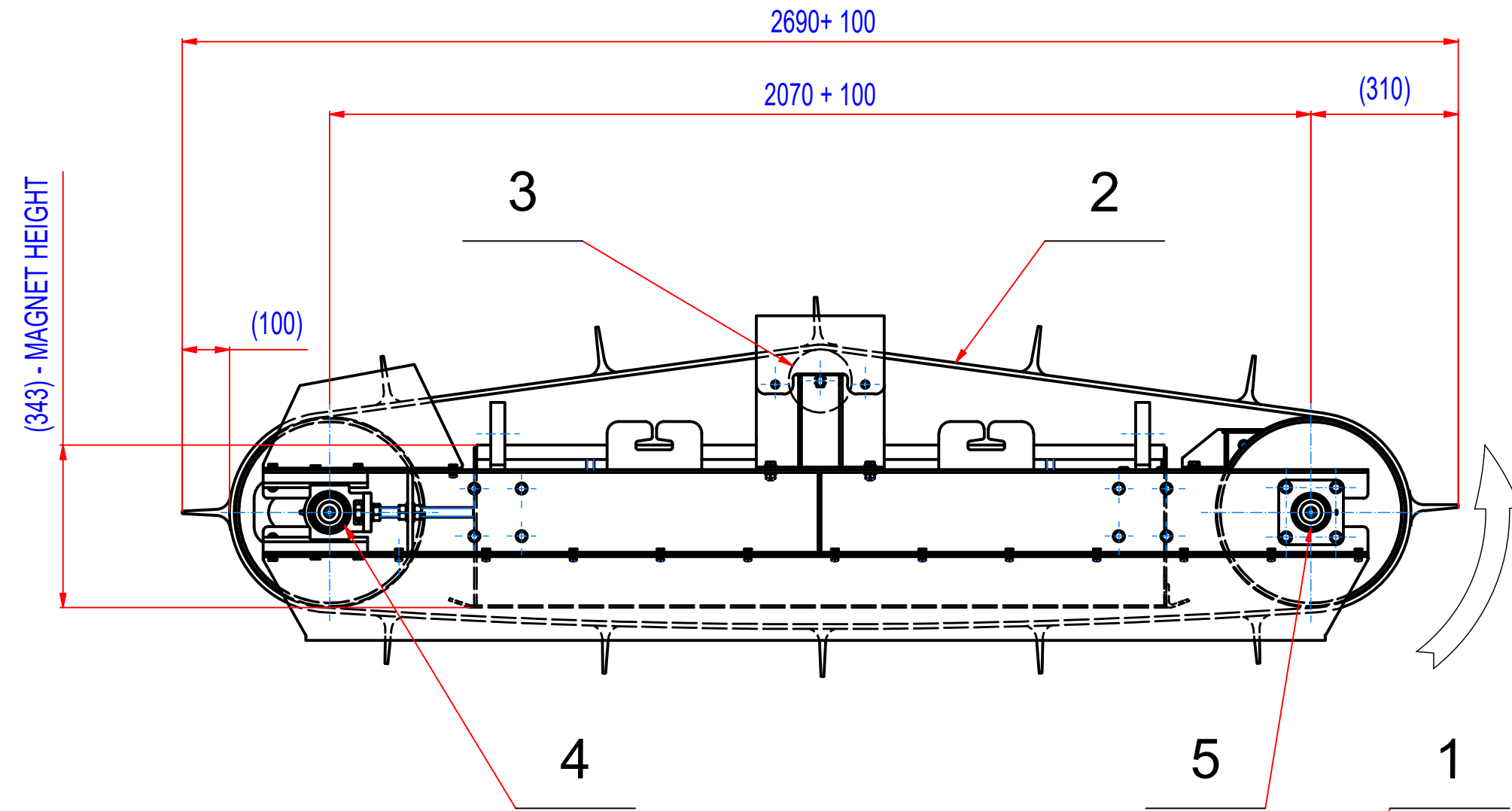

- GEARED BOX SEW SA67/TDRN100L4, i=20,37 (71RPM),
 MOTOR 230/400V, 3kW, 50Hz, IP55
 - DRUM SPEED 71/min
 - BELT SPEED 1,5m/s
 - BELT EP500/4 5+2, LENGTH 5460, WIDTH 1000,
 12 CLEATS T100/10, WIDTH 900

POZ.	Č. SOUČÁSTI	POPIS	MATERIÁL	HMOT.	MN.
5	15_8700045	BEARINGS ASSEMBLY INA PCJ 45		2,5	2
4	15_8600045	BEARINGS ASSEMBLY INA PTUE 45		2,7	2
3	1510_00009	PLAIN ROLLER 133x1150/6306		23,9	1
2	45_4100005	BELT EP500/4 5+2, W=1000, L=5460	RUBBER	68,6	1
1	MO30007116	SEW SA67/TDRN100L4, 3kW, i=20,37 (71 RPM)		64	1

Sheet: A2 Drawn: PW Date: 14.12.2017 Predecessor: SEPB120035 Quick search: XSPB 5 Description: SPARE PARTS FOR ROFC120350	Extra info: <small>© All rights reserved. Reproduction is not permitted without written permission of GOUDSMIT Magnetic Systems BV</small>	General tolerance: ISO 2768 - cL Drawn according: ISO268; ISO1101; ISO2553 Status: Customer reference number: Product key: ROP-F5-C-120-W-G-L-B-B-NA Part number: ROFC120350_SP Rev: A
--	---	---