

| REV | BY | DATE | DESCRIPTION |
|-----|----|------------|---|
| - | LF | 19.12.2018 | ORIGINAL DRAWING |
| A | LF | 09.02.2022 | BELT CLEATS 50mm (WAS 100), MOTOR IP55 (WAS IP54) |

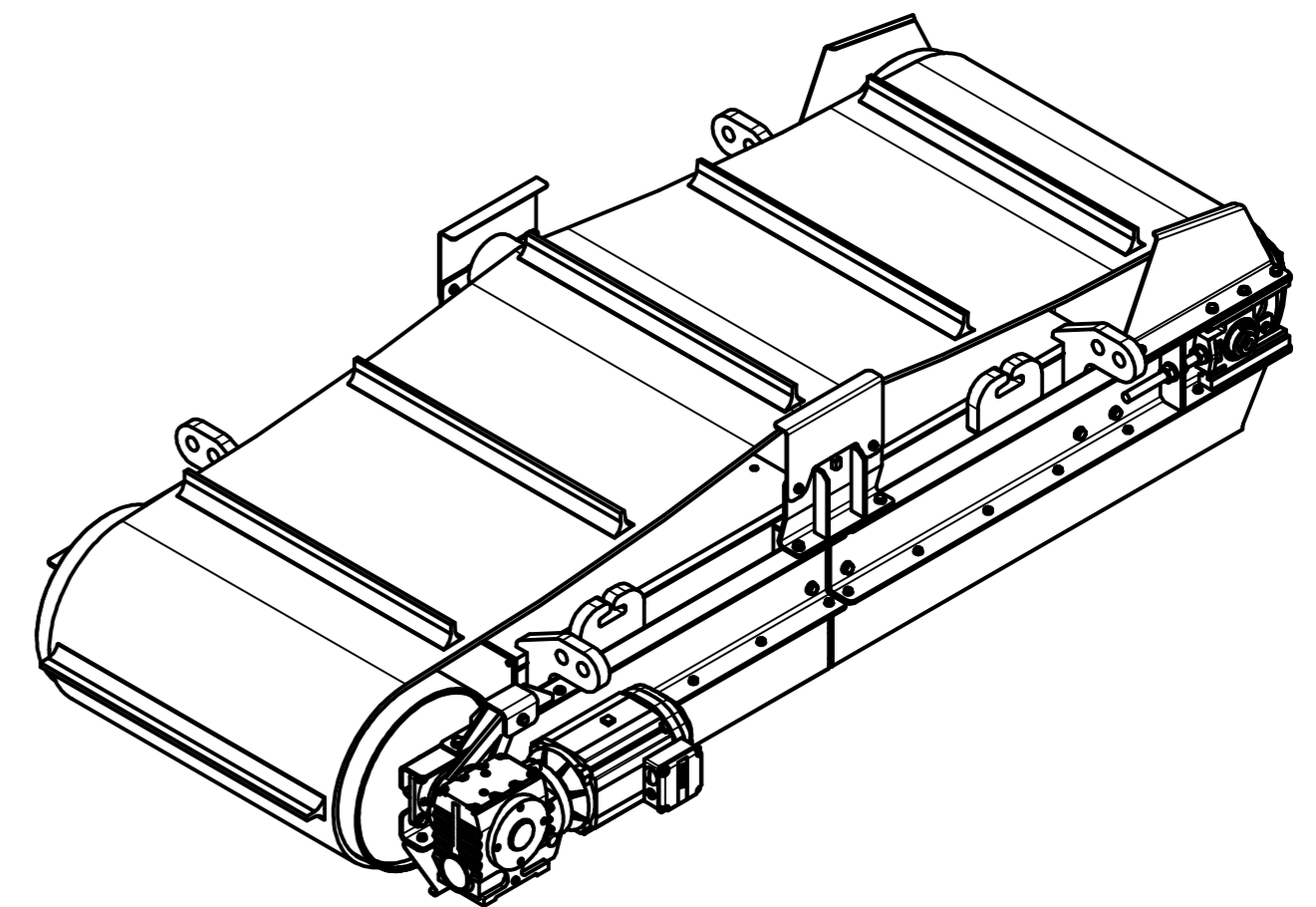
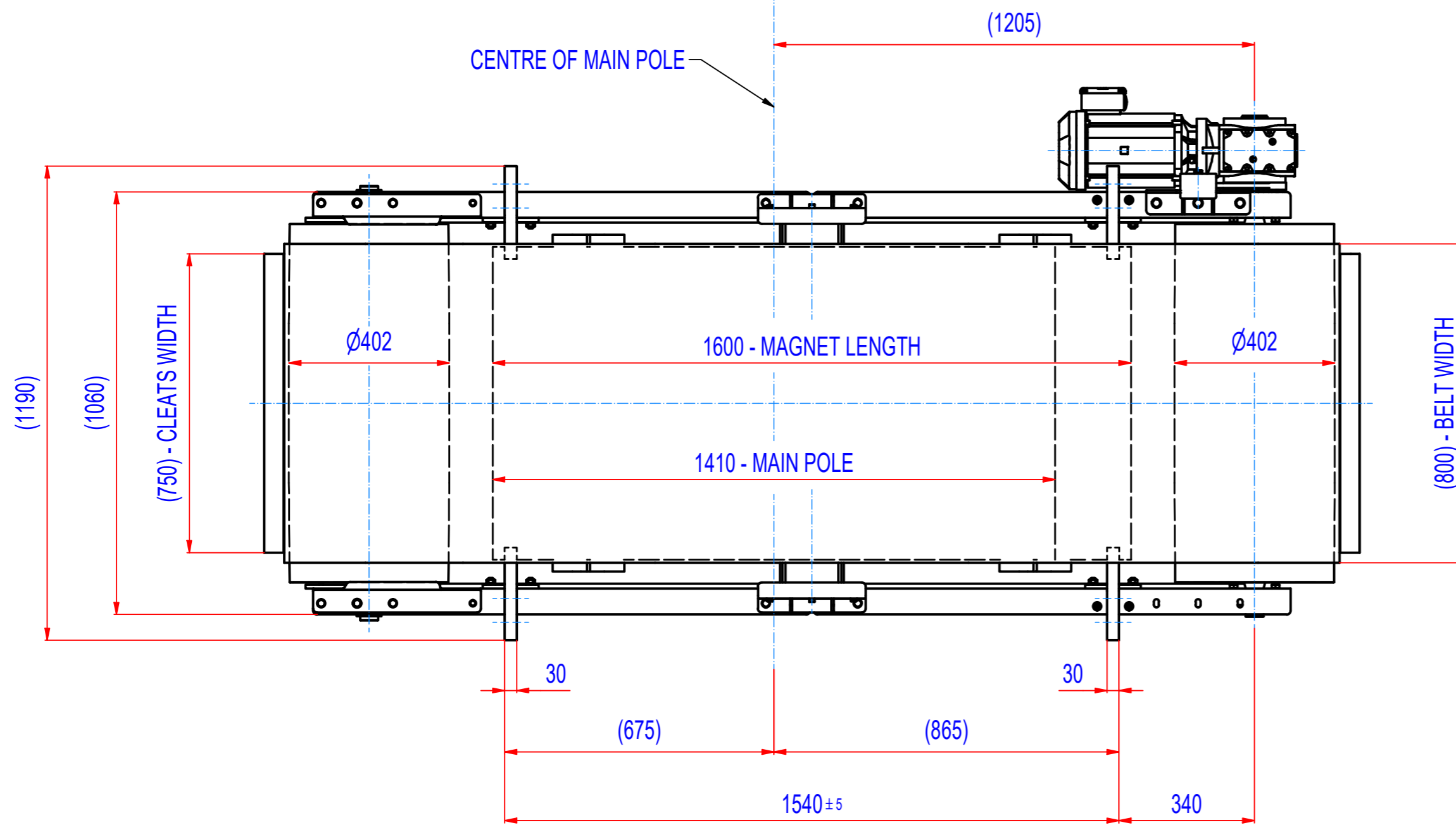
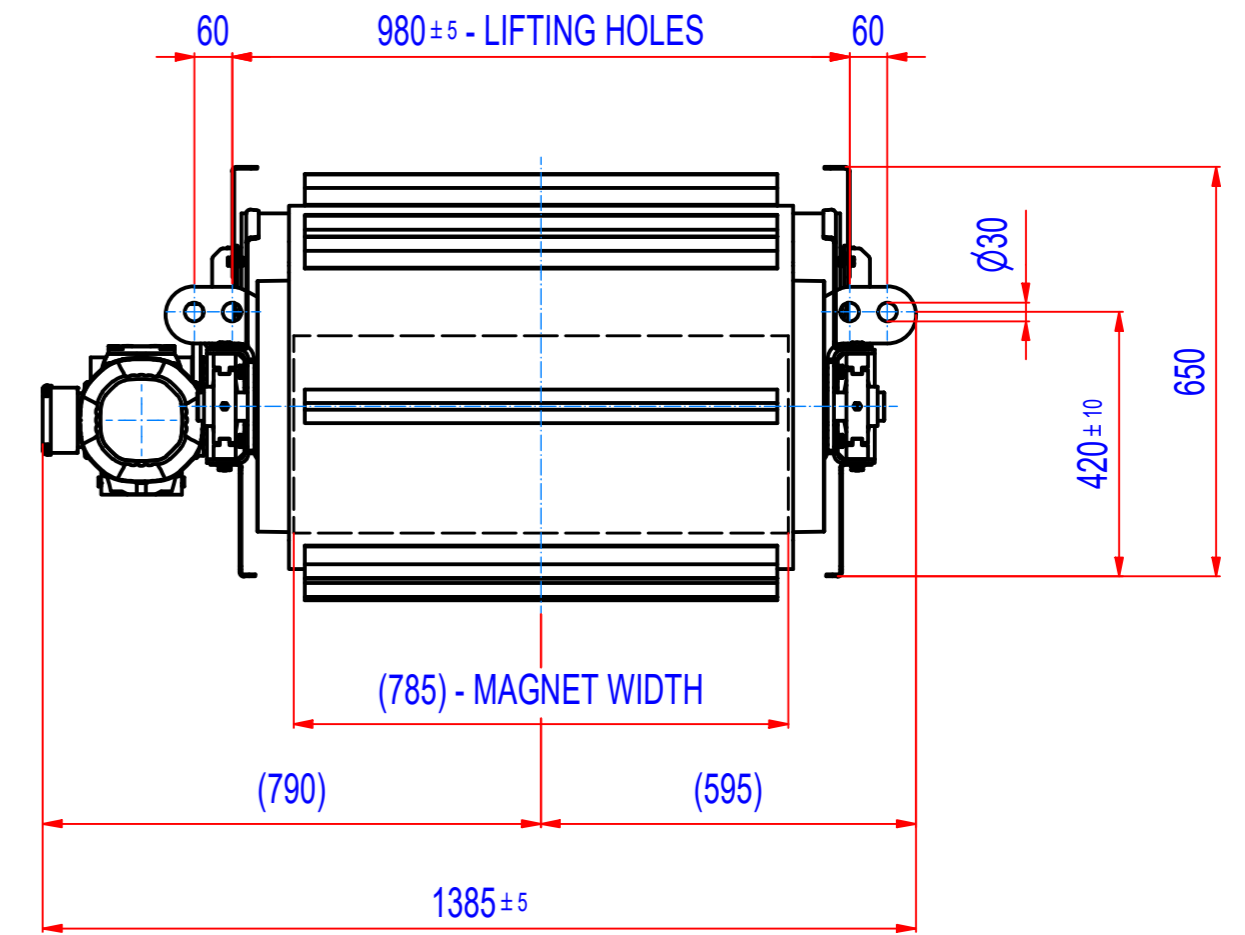
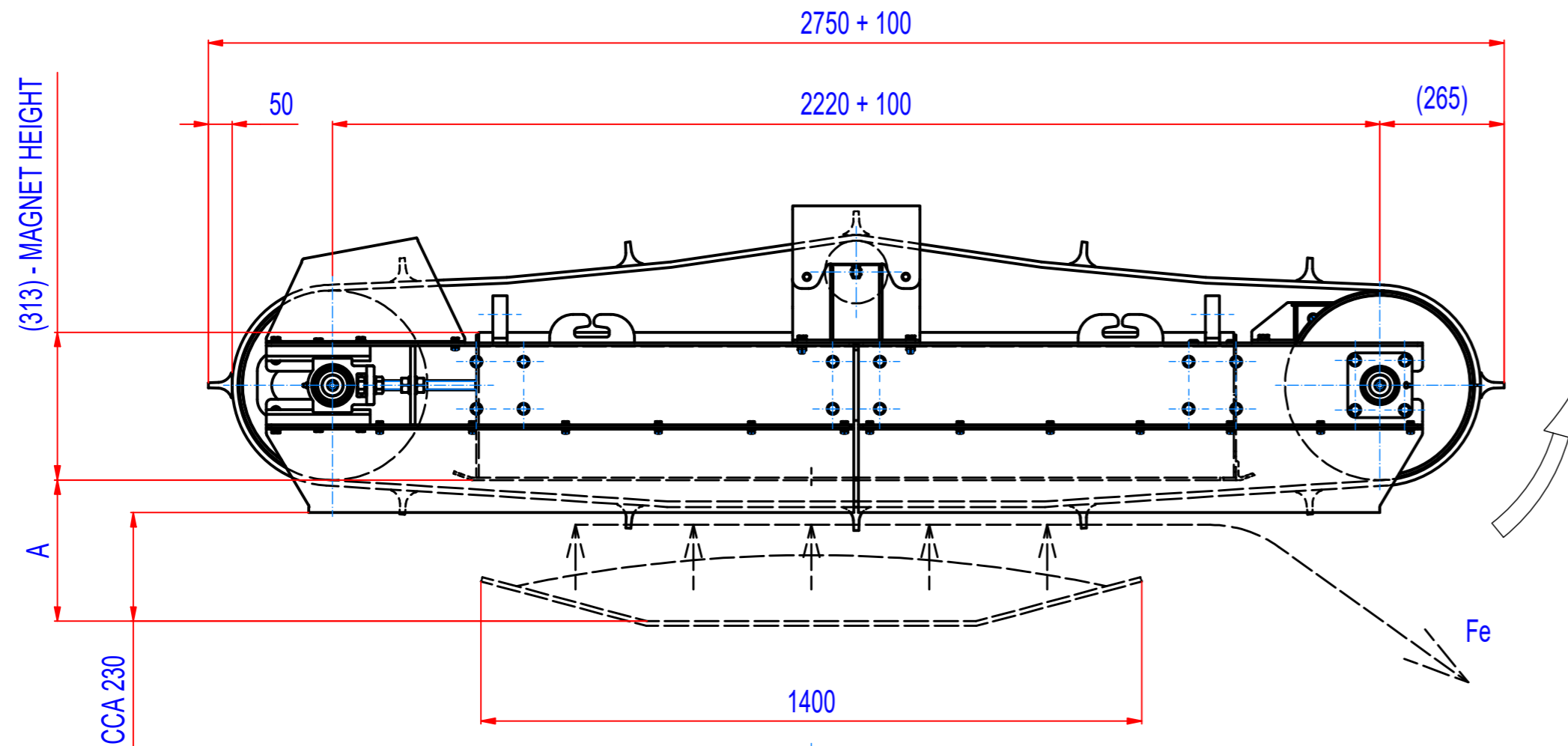

A = 380 mm - max. catch distance for rod Ø15, L=75 mm (VDE)
 A = 300 mm - 400 Gs

- GEARED BOX SEW SA67/TRDN100L4; i=20,37 (71RPM);
 MOTOR 230/400V; 3kW; 50Hz; IP55
 - ROLLER SPEED 71/min
 - BELT SPEED 1,5m/s
 - BELT EP500/4 5+2; LENGTH 5770, WIDTH 800;
 12 CLEATS T50/10, WIDTH 750

| | | |
|--|---|---|
| Sheet: A2 | Extra info: | General tolerance: ISO 2768 - cL |
| Drawn: LF | Weight (kg): 2142,1 kg | Drawn according: ISO268; ISO1101; ISO2553 |
| Date: 19.12.2018 | | Status: |
| Predecessor: SEPB140034 | | Customer reference number: |
| Quick search: XSPB 4 | © All rights reserved. Reproduction is not permitted without written permission of GOUDSMIT Magnetic Systems BV | Product key: ROP-F4-C-140-W-G-L-B-B-NA |
| Description: Overband separator, Ferrite, Size 4, W1400, Cross | | Part number: ROFC140340 |
| | | Rev: A |