

REV	BY	DATE	DESCRIPTION
-	LF	19.12.2018	ORIGINAL DRAWING
A	LF	09.02.2022	BELT CLEATS 50mm (WAS 100), MOTOR IP55 (WAS IP54) 14.03.2023 - REDUCTION IN THE NUMBER OF SPARE PARTS

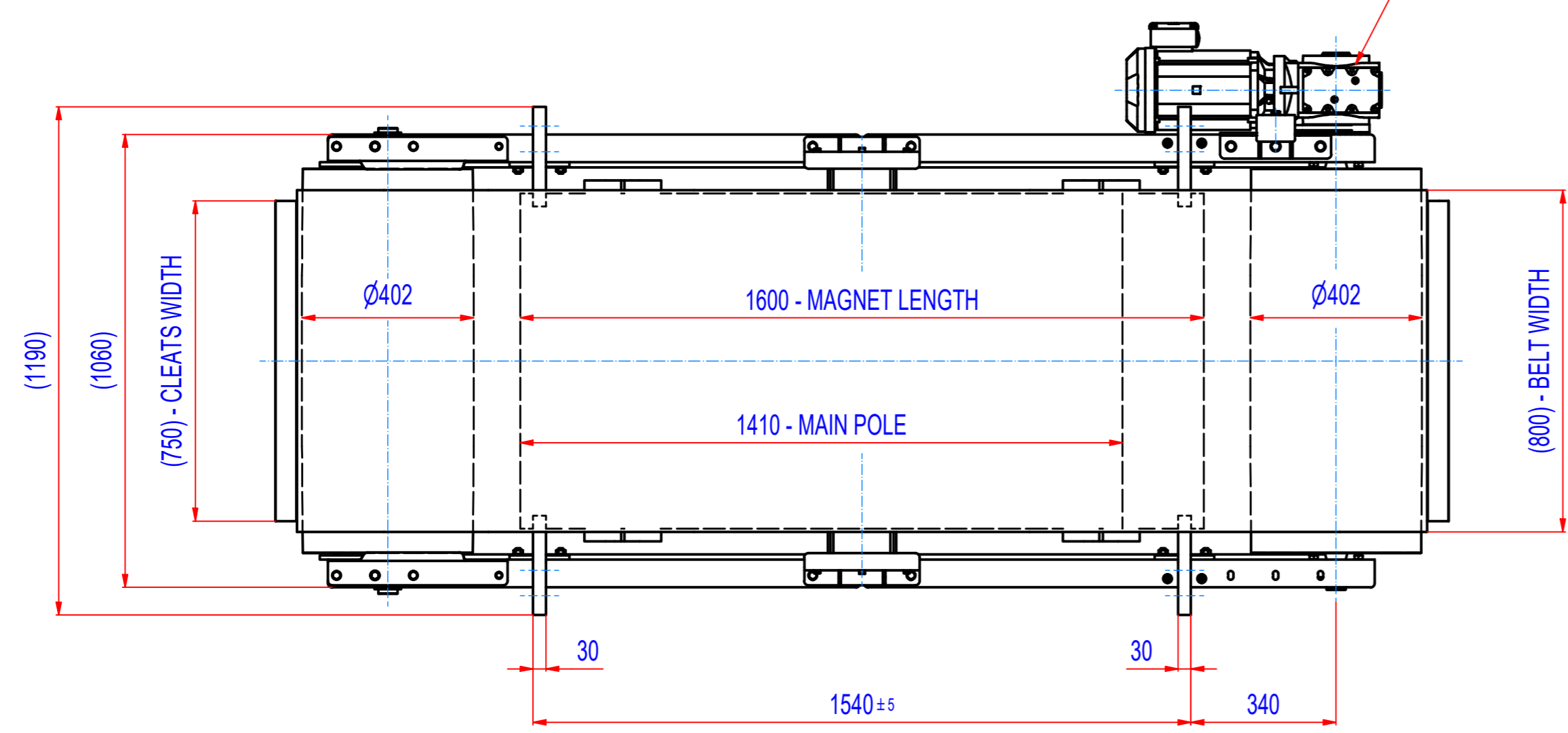
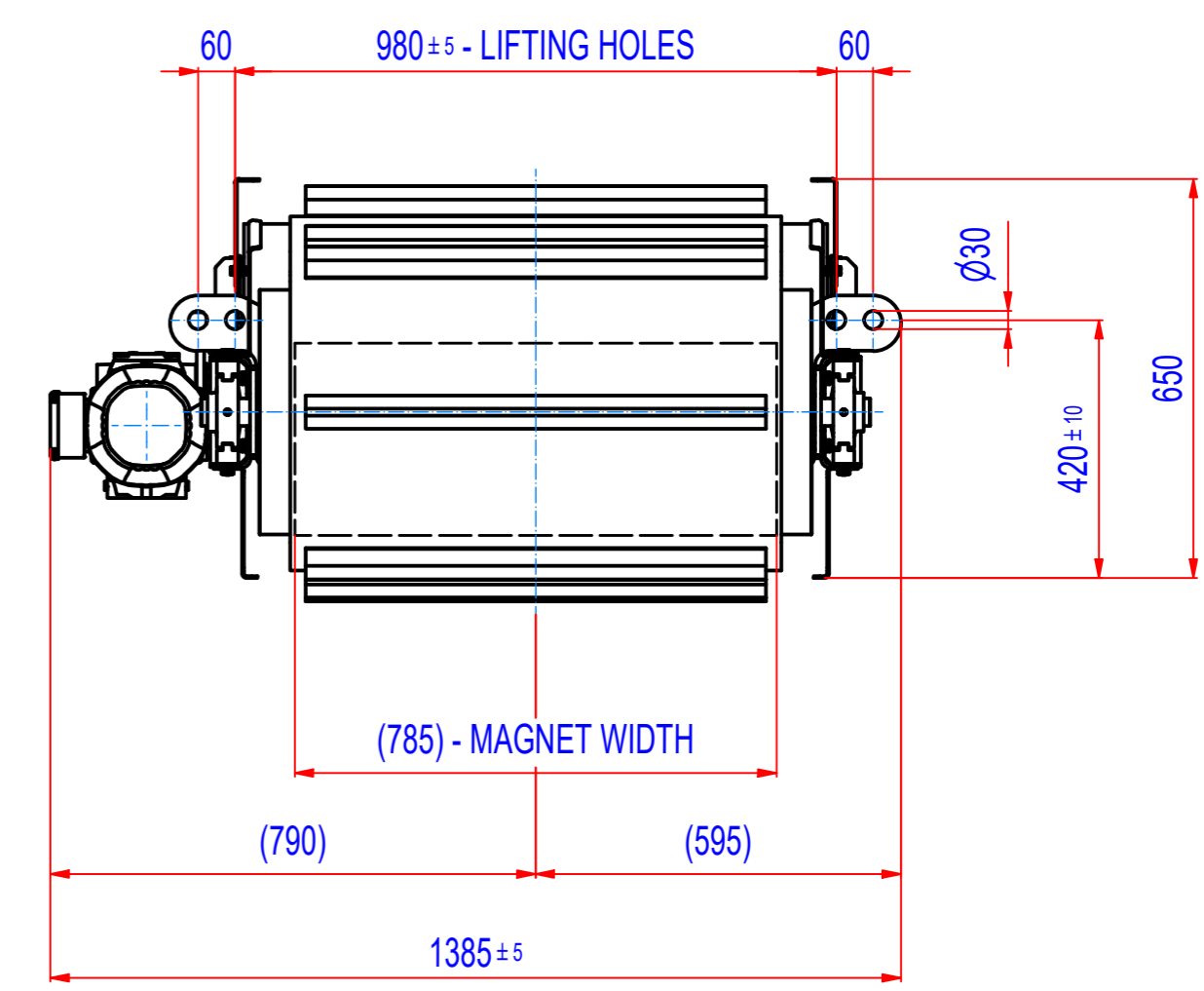
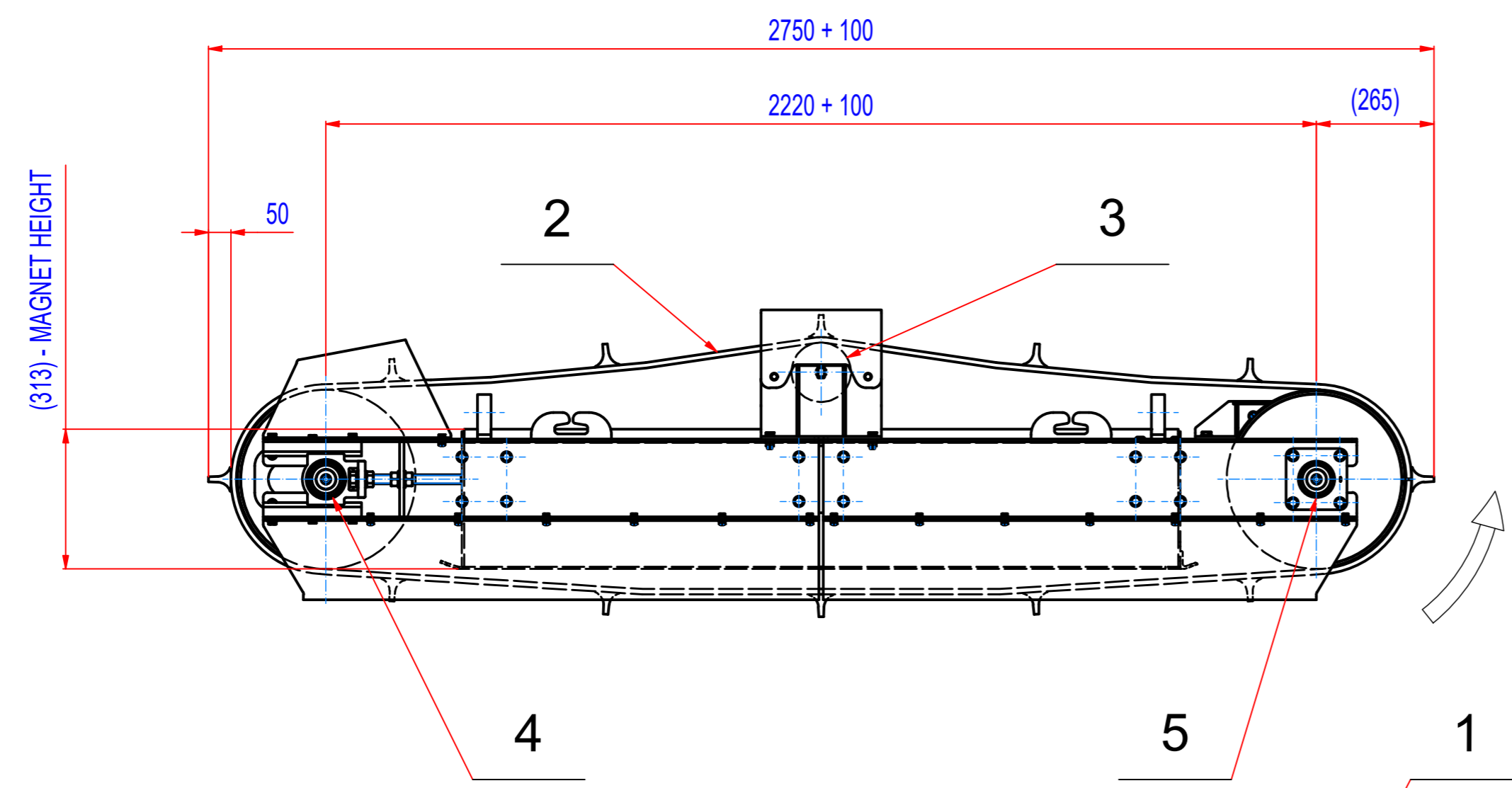

- GEARED BOX SEW SA67/TDRN100L4; i=20,37 (71RPM);  
 MOTOR 230/400V; 3kW; 50Hz; IP55  
 - ROLLER SPEED 71/min  
 - BELT SPEED 1,5m/s  
 - BELT EP500/4 5+2; LENGTH 5770, WIDTH 800;  
 12 CLEATS T50/10, WIDTH 750

POZ.	Č. SOUČÁSTI	POPIS	MATERIÁL	HMOT.	MN.
5	15_8700045	BEARINGS ASSEMBLY INA PCJ 45		2,5	2
4	15_8600045	BEARINGS ASSEMBLY INA PTUE 45		2,7	2
3	1510_00055	PLAIN ROLLER d=133, L=950, 6306		20,1	1
2	45_4080052	BELT EP500/4 5+2, W=800, L=5770	RUBBER	68	1
1	MO30007116	SEW SA67/TDRN100L4, 3kW, i=20,37 (71 RPM)		64	1

Sheet: A2 Drawn: LF Date: 19.12.2018 Predecessor: SEP140034 Quick search: XSPB 4 Description: SPARE PARTS FOR ROFC140340	Weight (kg): 2142  © All rights reserved. Reproduction is not permitted without written permission of GOUDSMIT Magnetic Systems BV	General tolerance: ISO 2768 - cL Drawn according: ISO268; ISO1101; ISO2553 Status: Customer reference number: Product key: ROP-F4-C-140-W-G-L-B-B-NA Part number: ROFC140340_SP Rev: A
---	--	--