

REV	DATE	BY	DESCRIPTION
-	10.05.2022	PH	Source ROFC140340, covering according size 3 for mobile unit

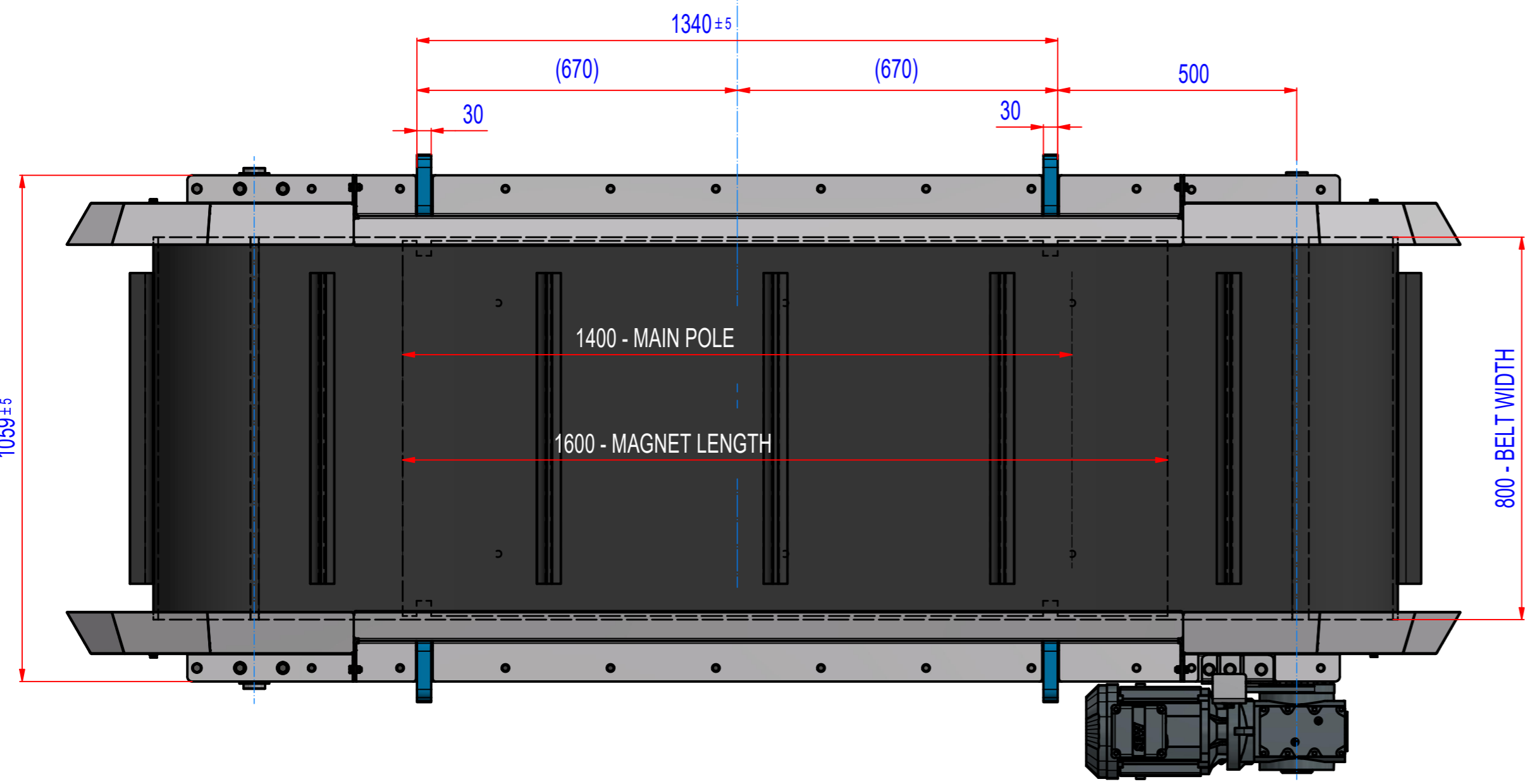
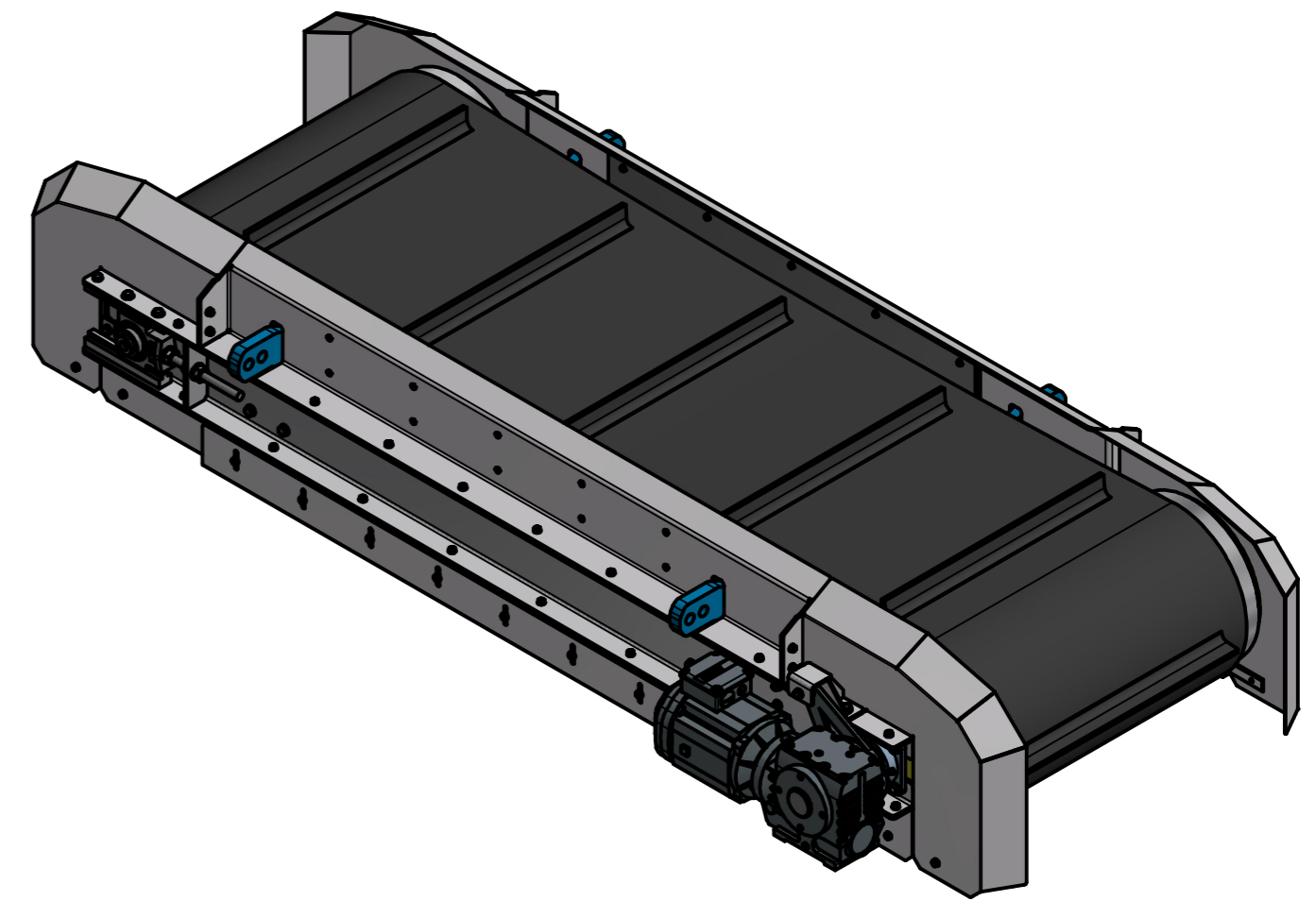
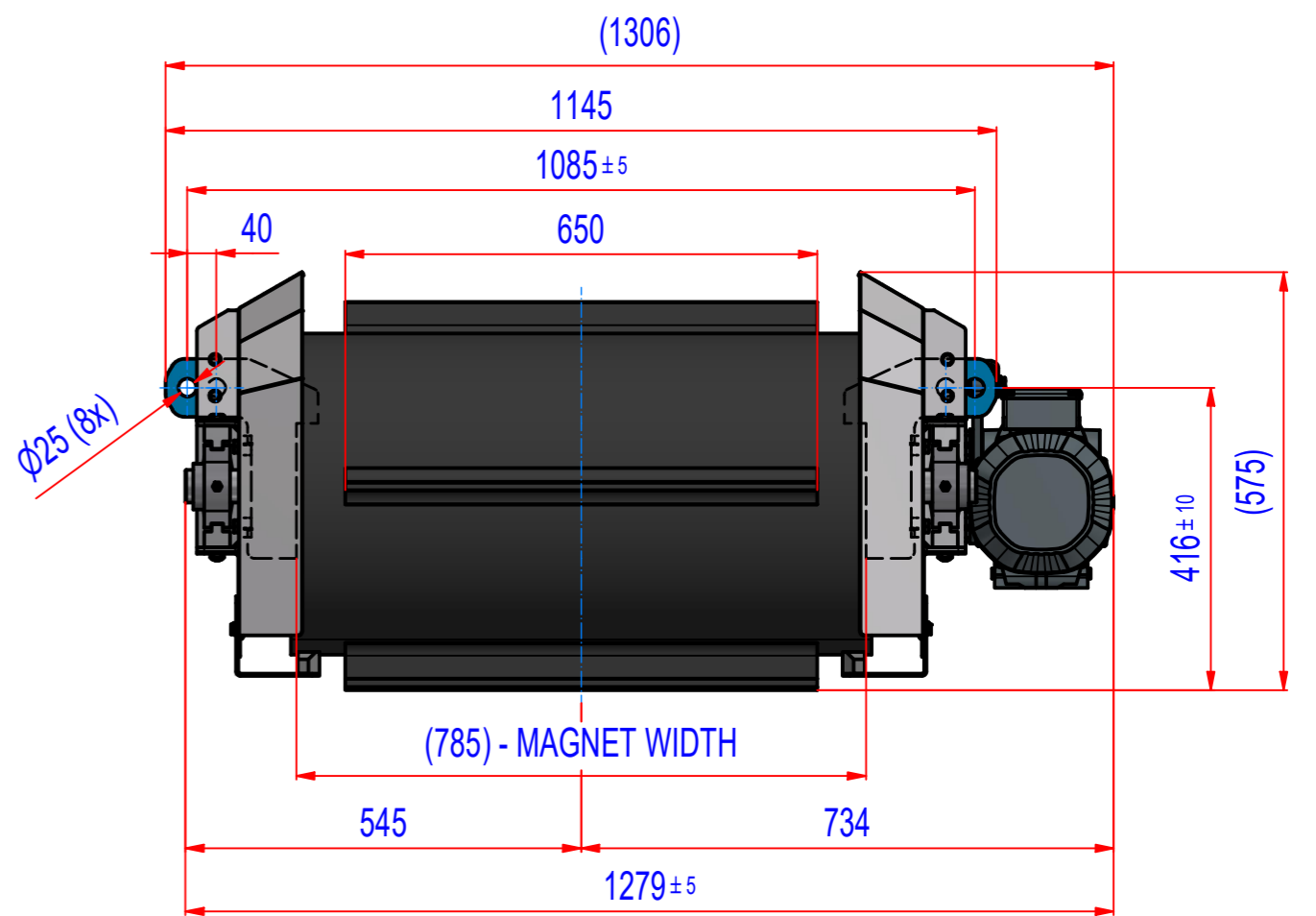
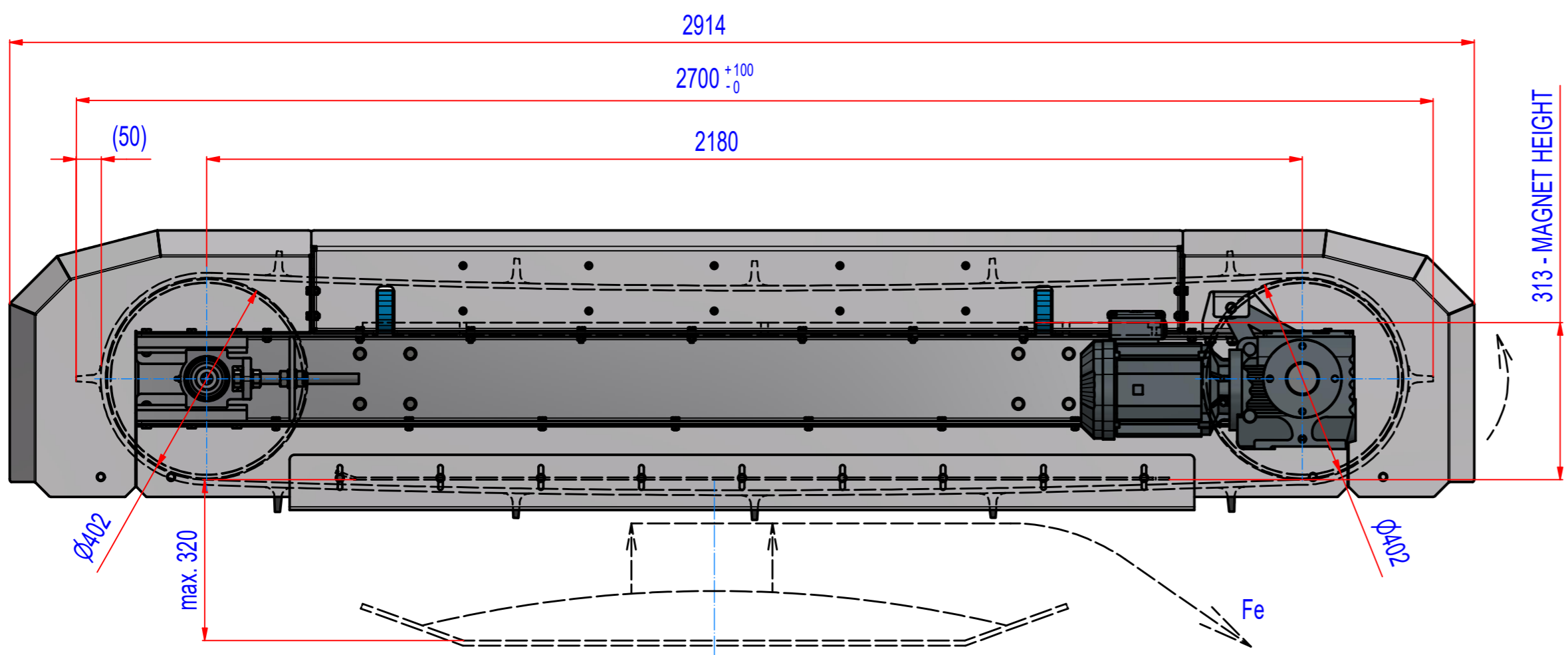

POZ./POS.	Č. SOUČÁSTI/ PART NUMBER	POPIS / DESCRIPTION	HMOT./ WEIGHT
1	B583_000000	ROFC140341	2166,5
Sheet: A2 Drawn: PH Date: 10.05.2022 Predecessor: ROFC140340 Quick search:		Extra info: <b>GOUDSMIT</b> <b>MAGNETICS</b> <small>© All rights reserved. Reproduction is not permitted without written permission of GOUDSMIT Magnetic Systems BV</small>	General tolerance: ISO 2768 - cL Drawn according: ISO268; ISO1101; ISO2553 Status: Customer reference number: Product key: ROP-F4-C-140-W-G-R-B-B-M-NA Part number: ROFC140341 Rev: -
Description:		Overband separator, Ferrite, size 4, W1400, spec for mobile	