

REV	BY	DATE	DESCRIPTION
-	LF	25.05.2018	NEW VAULT, REF. ROFC140350_C
A	LF	09.02.2022	MOTOR IP55 (WAS IP54)

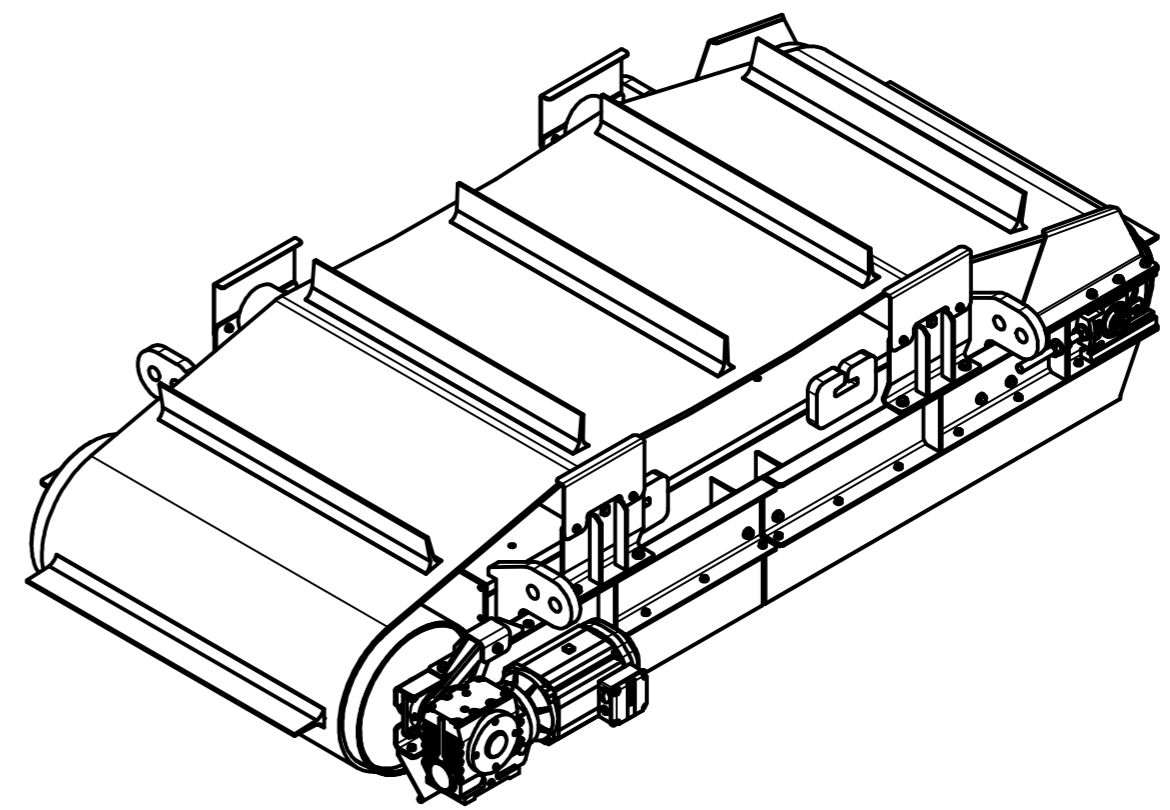
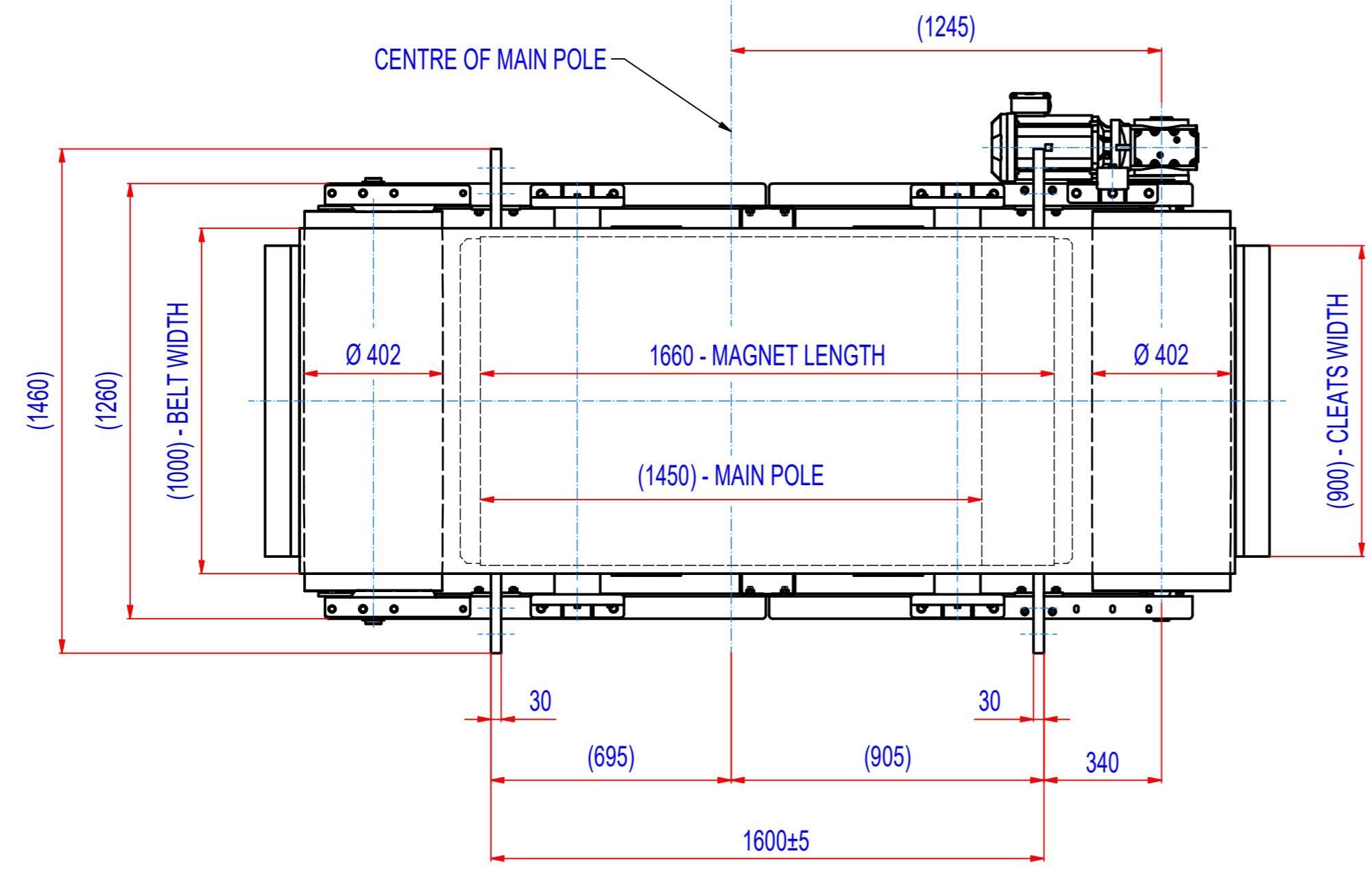
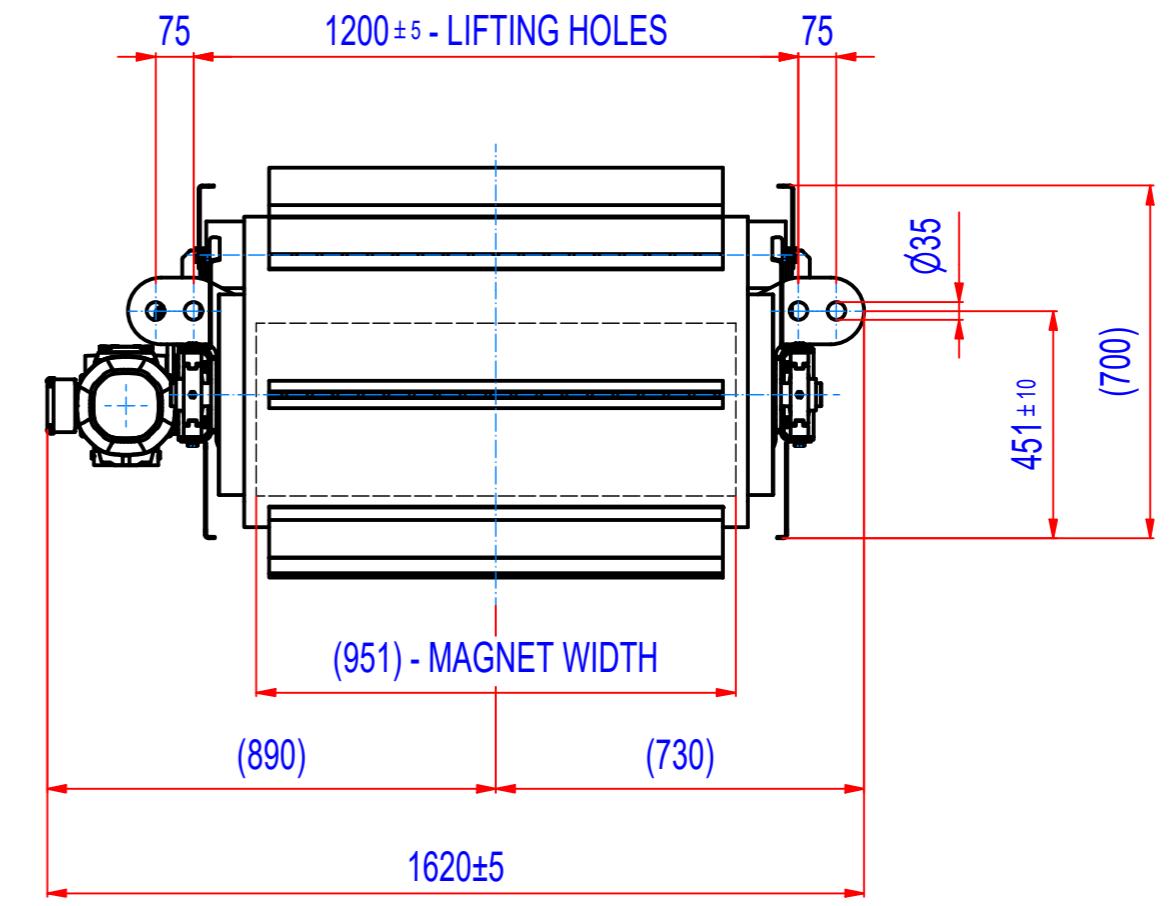
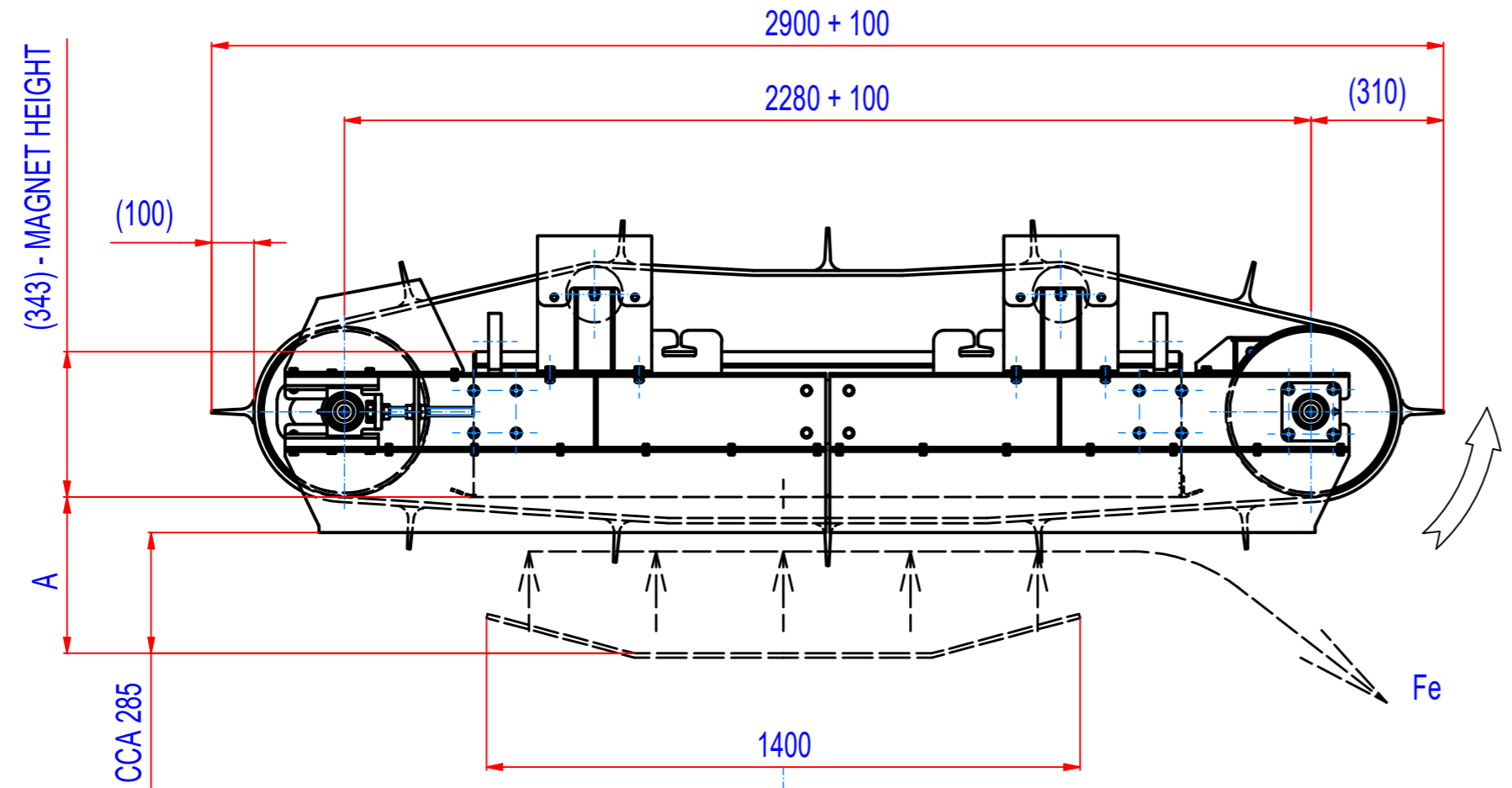

A = 430 mm - max. catch distance for rod Ø15, L=75 mm (VDE)
A = 370 mm - 400 Gs

- GEARED BOX SEW SA67/TDRN100L4, i=20,37 (71RPM),
MOTOR 230/400V, 3kW, 50Hz, IP55
- DRUM SPEED 71/min
- BELT SPEED 1,5 m/s
- BELT EP500/4 5+2, LENGTH 5920, WIDTH 1000,
12 CLEATS T100/10, WIDTH 900

Sheet: A2	Extra info:	General tolerance: ISO 2768 - cL
Drawn: LF	Weight (kg): 2839,6 kg	Drawn according: ISO268; ISO1101; ISO2553
Date: 25.5.2018		Status:
Predecessor: SEPB140035		Customer reference number:
Quick search: XSPB 5	© All rights reserved. Reproduction is not permitted without written permission of GOUDSMIT Magnetic Systems BV	Product key: ROP-F5-C-140-W-G-L-B-B-NA
Description: Overband separator, Ferrite, Size 5, W1400, Cross		Part number: ROFC140350 Rev: A