

REV	BY	DATE	DESCRIPTION
-	LF	25.05.2018	NEW VAULT, REF. ROFC140350_C
A	LF	09.02.2022	MOTOR IP55 (WAS IP54)
			20.03.2023 - REDUCTION IN THE NUMBER OF SPARE PARTS

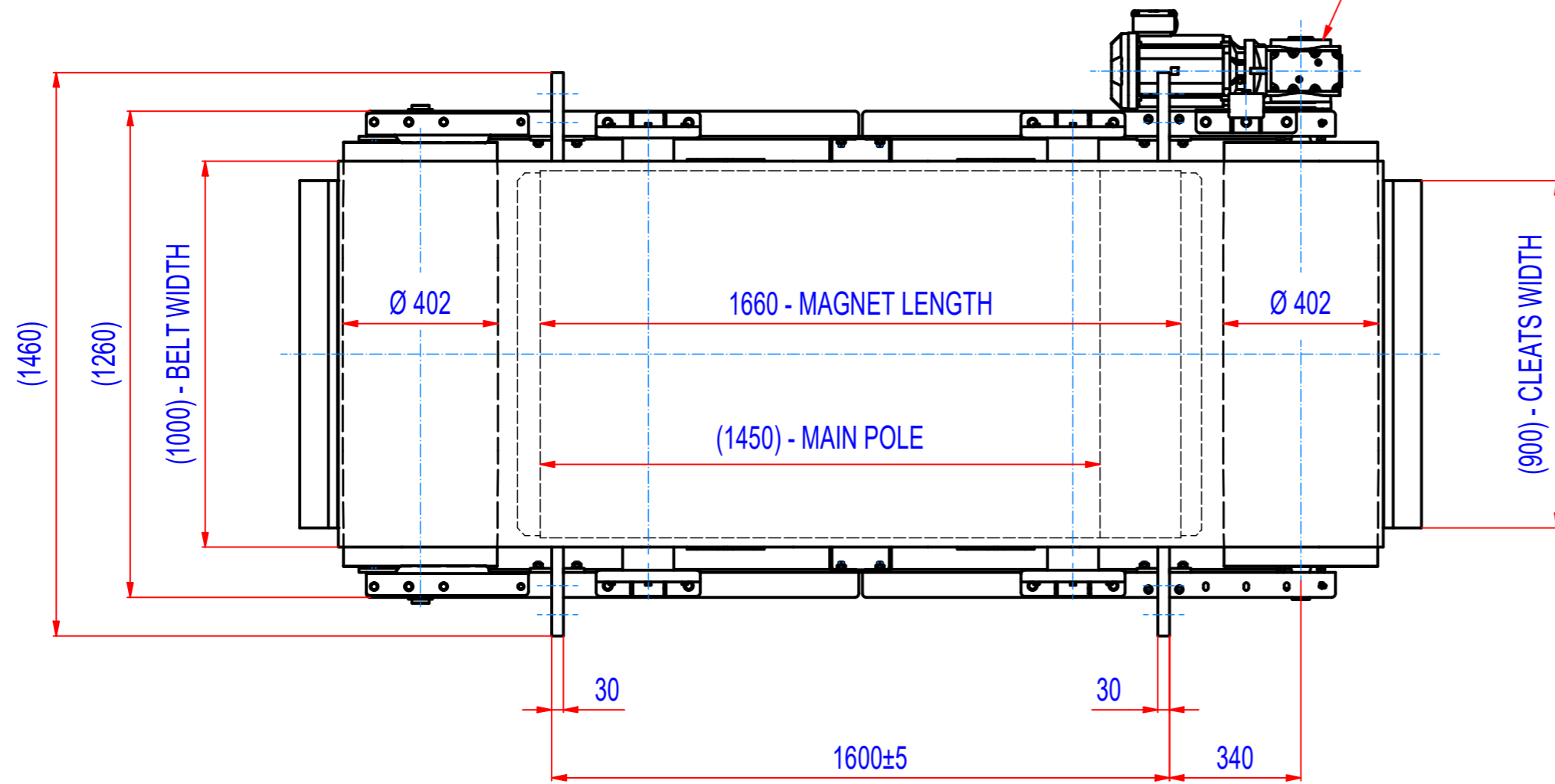
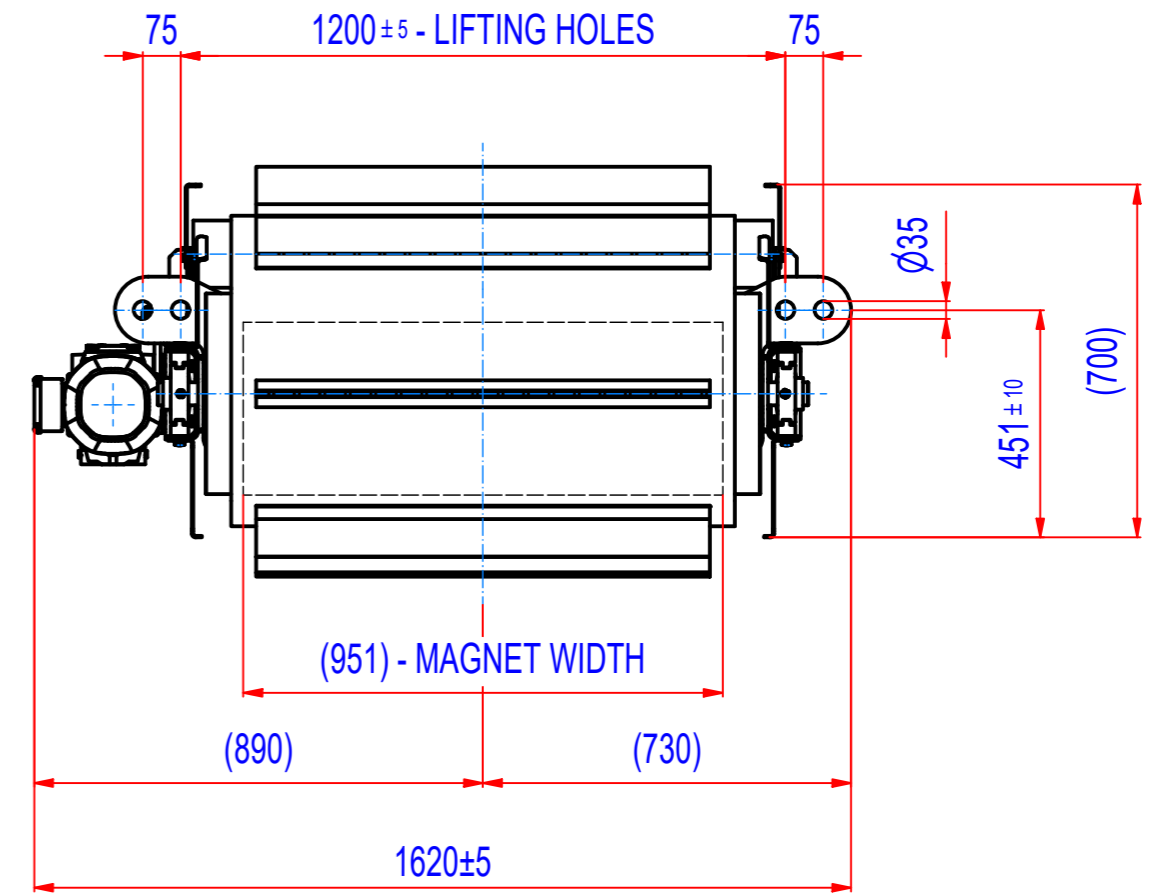
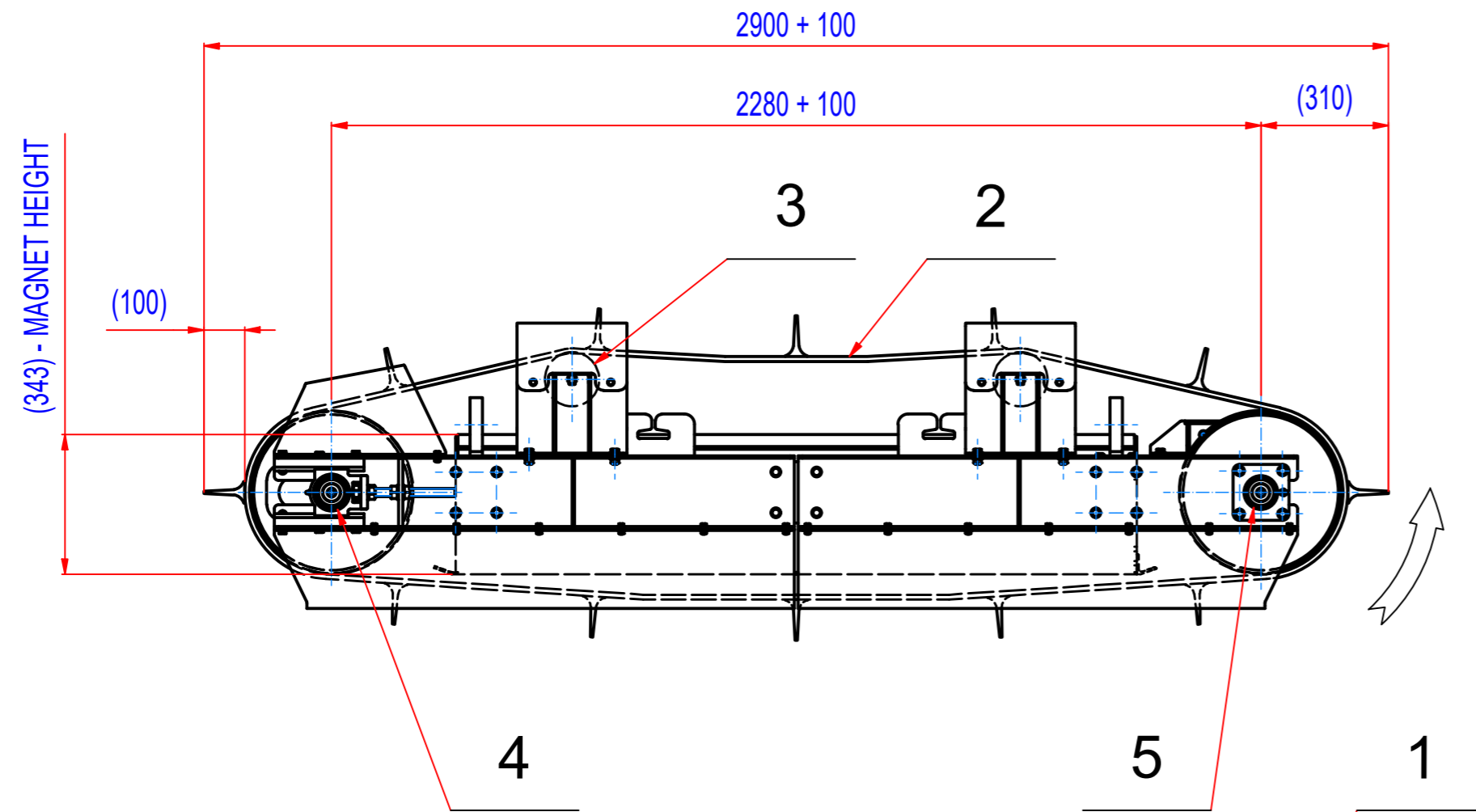

- GEARED BOX SEW SA67/TDRN100L4, i=20,37 (71RPM), MOTOR 230/400V, 3kW, 50Hz, IP55
- DRUM SPEED 71/min
- BELT SPEED 1,5 m/s
- BELT EP500/4 5+2, LENGTH 5920, WIDTH 1000, 12 CLEATS T100/10, WIDTH 900

POZ.	Č. SOUČÁSTI	POPIS	MATERIÁL	HMOT.	MN.
5	15_8700045	BEARINGS ASSEMBLY INA PCJ 45		2,5	2
4	15_8600045	BEARINGS ASSEMBLY INA PTUE 45		2,7	2
3	1510_00009	PLAIN ROLLER 133x1150/6306		23,9	2
2	45_4100022	BELT EP 500/4 5+2, W=1000, L=5920	RUBBER	104	1
1	MO30007116	SEW SA67/TDRN100L4, 3kW, i=20,37 (71 RPM)		64	1

Sheet: A2 Drawn: LF Date: 25.5.2018 Predecessor: SEPB140035 Quick search: XSPB 5 Description: SPARE PARTS FOR ROFC140350	Weight (kg): 2839.5 © All rights reserved. Reproduction is not permitted without written permission of GOUDSMIT Magnetic Systems BV	Extra info: General tolerance: ISO 2768 - cL Drawn according: ISO268; ISO1101; ISO2553 Status: Customer reference number: Product key: ROP-F5-C-140-W-G-L-B-B-NA Part number: ROFC140350_SP Rev: A
---	---	--