

REV	BY	DATE	DESCRIPTION
-	EN	25.01.2019	New Vault, old rev. was C, belt covers not splitted
A	LF	15.03.2023	BELT CLEATS 50mm WAS 100), MOTOR IP55 (WAS IP54), BELT COVERS SPLITTED

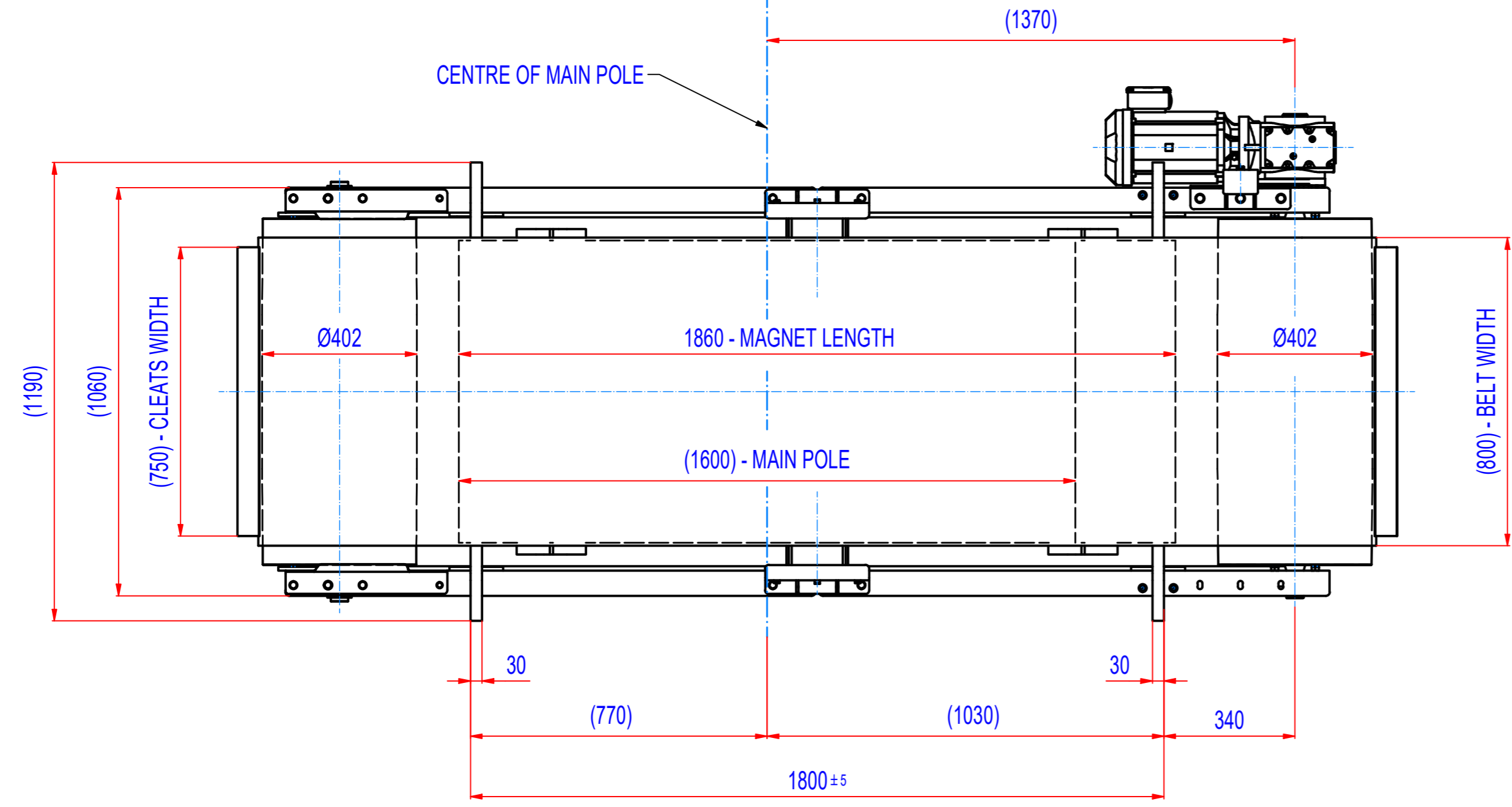
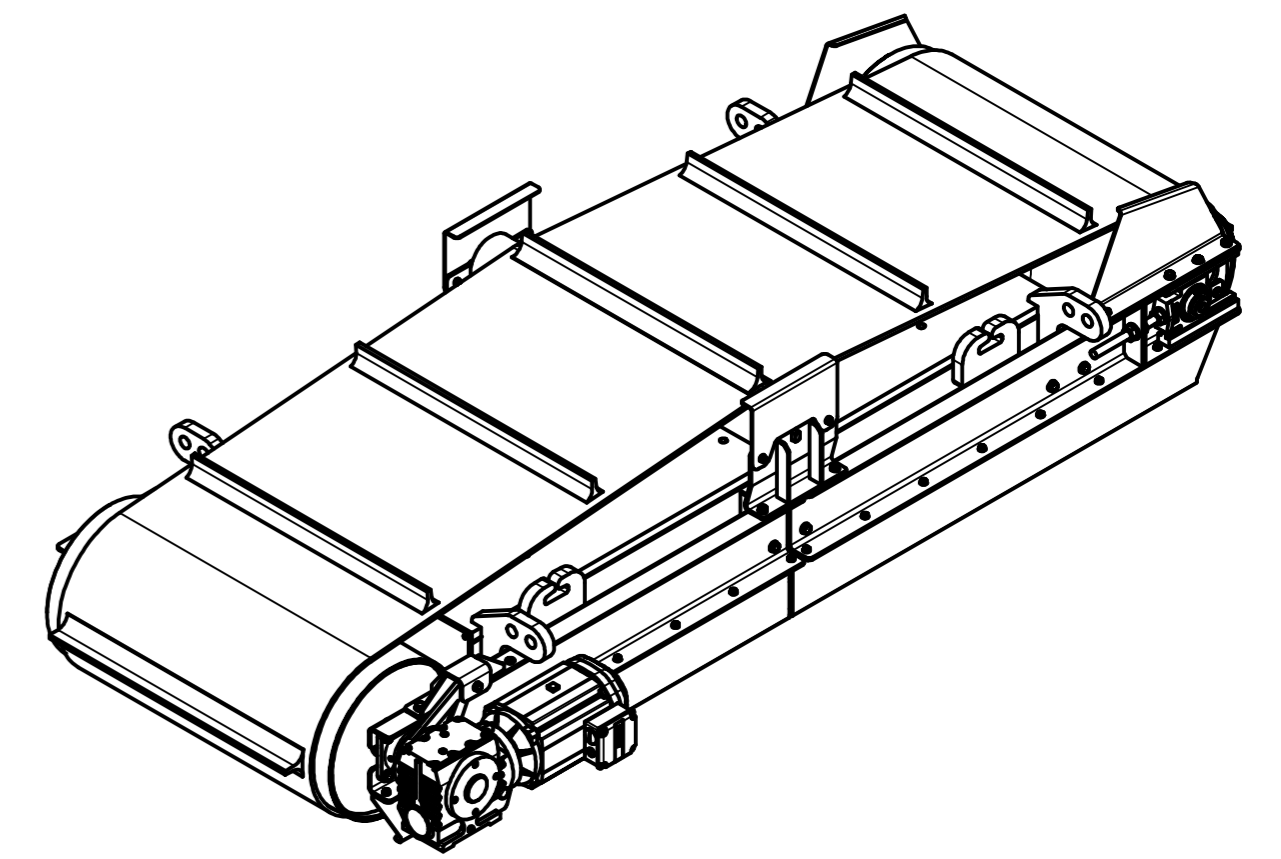
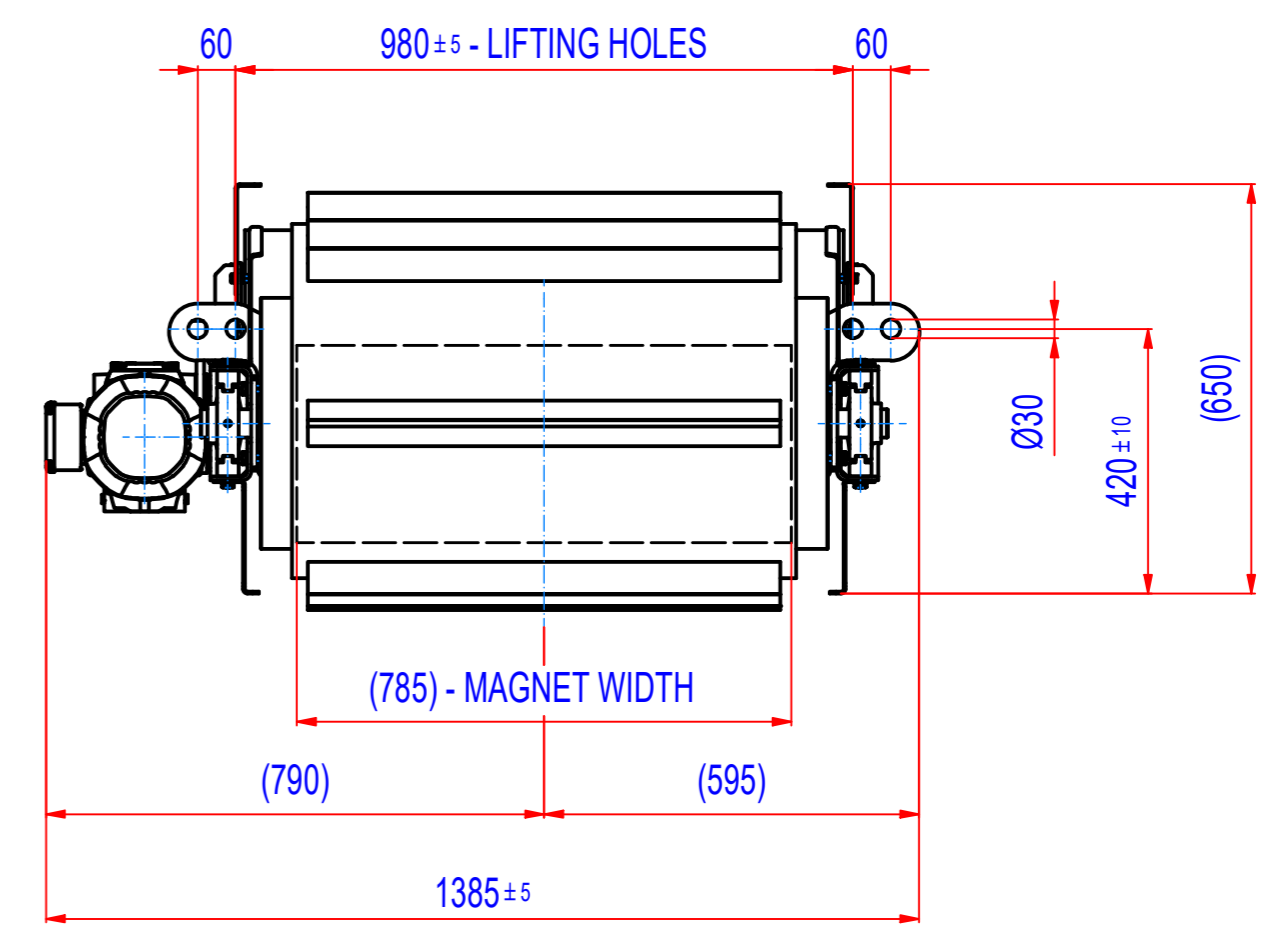
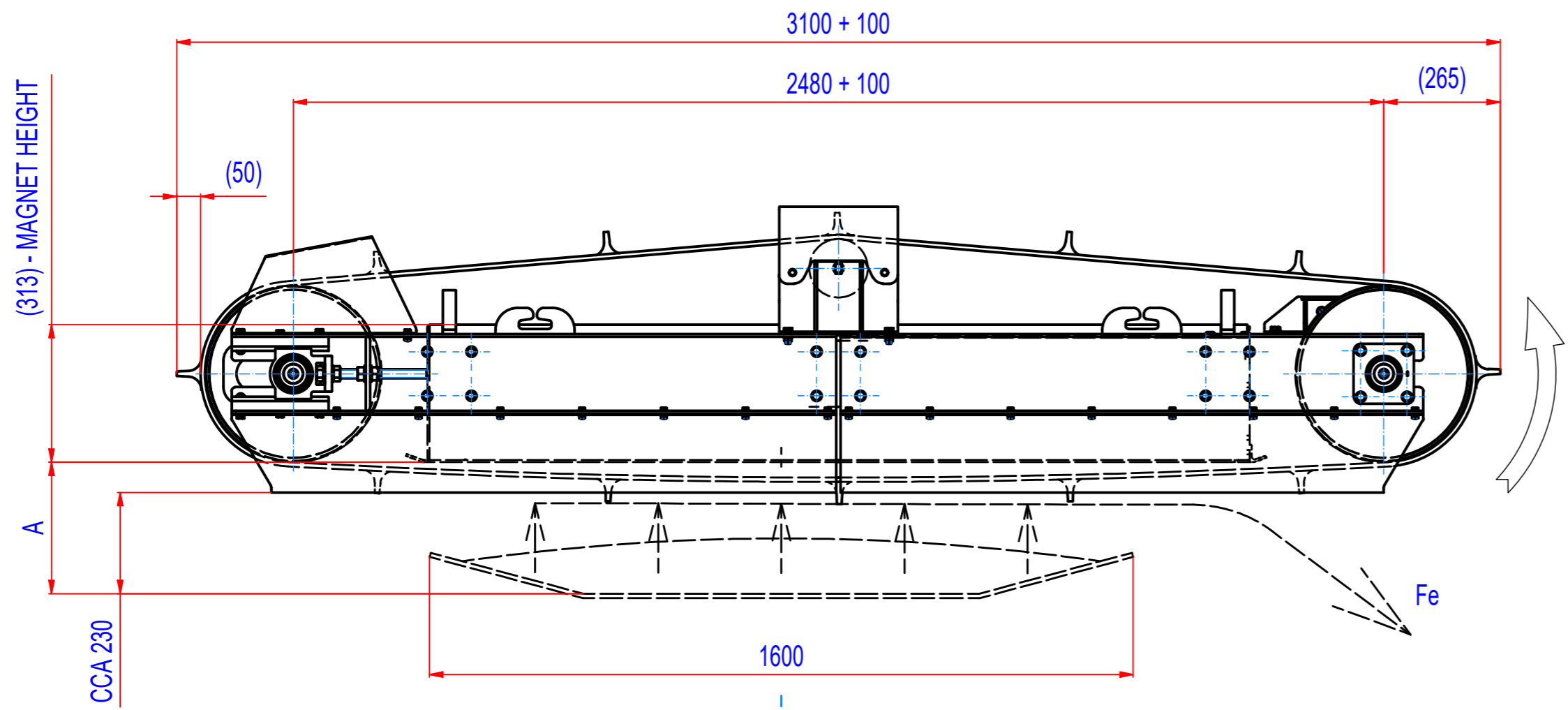

A = 380 mm - max. catch distance for rod Ø15, L=75 mm (VDE)
A = 300 mm - 400 Gs

- GEARED BOX SEW SA67/TDRN100L4; i=20,37 (71RPM); MOTOR 230/400V; 3kW; 50Hz; IP55
- ROLLER SPEED 71/min
- BELT SPEED 1,5m/s
- BELT EP500/4 5+2; LENGTH 6280, WIDTH 800; 12 CLEATS T50/10, WIDTH 750

Sheet: A2	Extra info:	General tolerance: ISO 2768 - cL
Drawn: EN	Weight (kg): 2404,6 kg	Drawn according: ISO268; ISO1101; ISO2553
Date: 25.01.2019		Status:
Predecessor: SEPB160034		Customer reference number:
Quick search: XSPB 4	© All rights reserved. Reproduction is not permitted without written permission of GOUDSMIT Magnetic Systems BV	Product key: ROP-F4-C-160-W-G-L-B-B-NA
Description: Overband separator, Ferrite, Size 4, W1600, Cross		Part number: ROFC160340
		Rev: A