

REV	BY	DATE	DESCRIPTION
-	EN	25.01.2019	New Vault, old rev. was A, belt covers not splitted
A	LF	15.03.2023	BELT CLEATS 50mm (WAS 100), MOTOR IP55 (WAS IP54), BELT COVERS SPLITTED 15.03.2023 - REDUCTION IN THE NUMBER OF SPARE PARTS

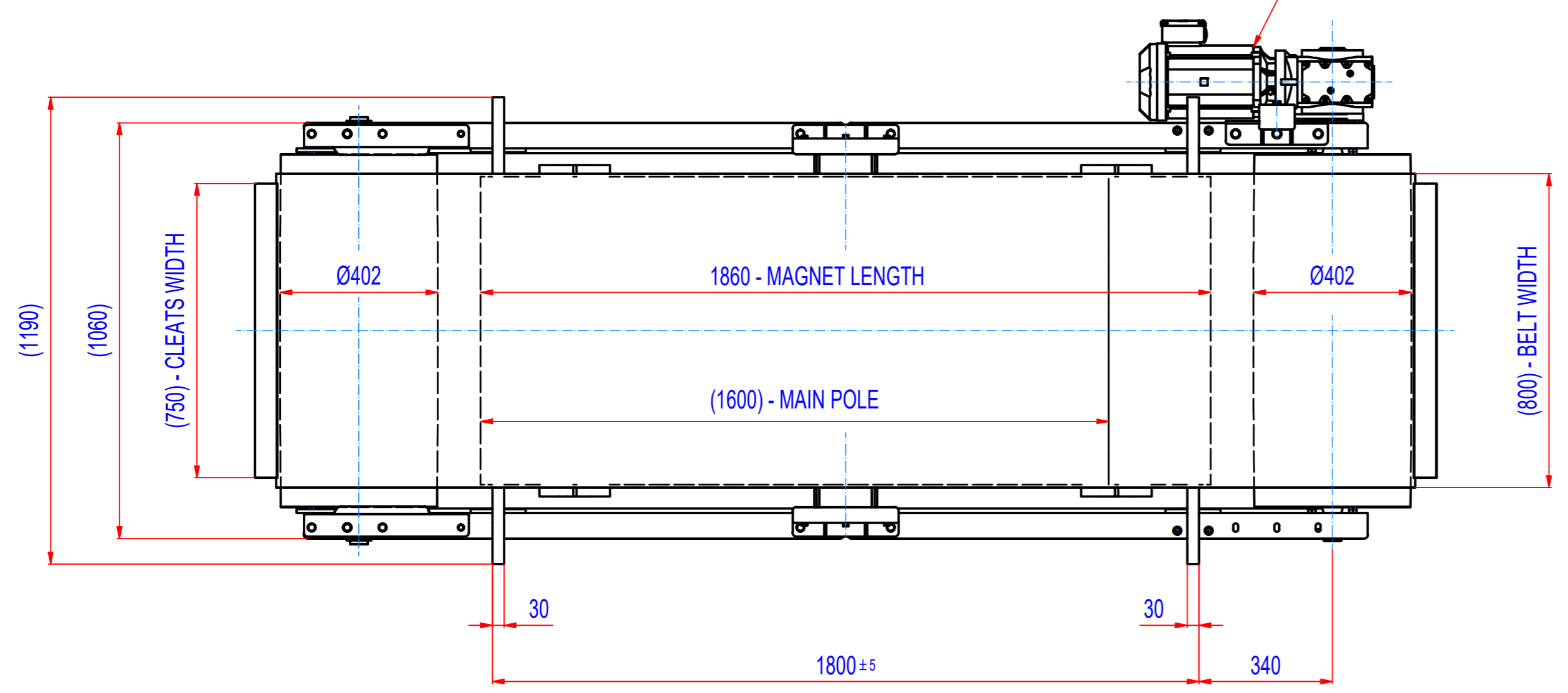
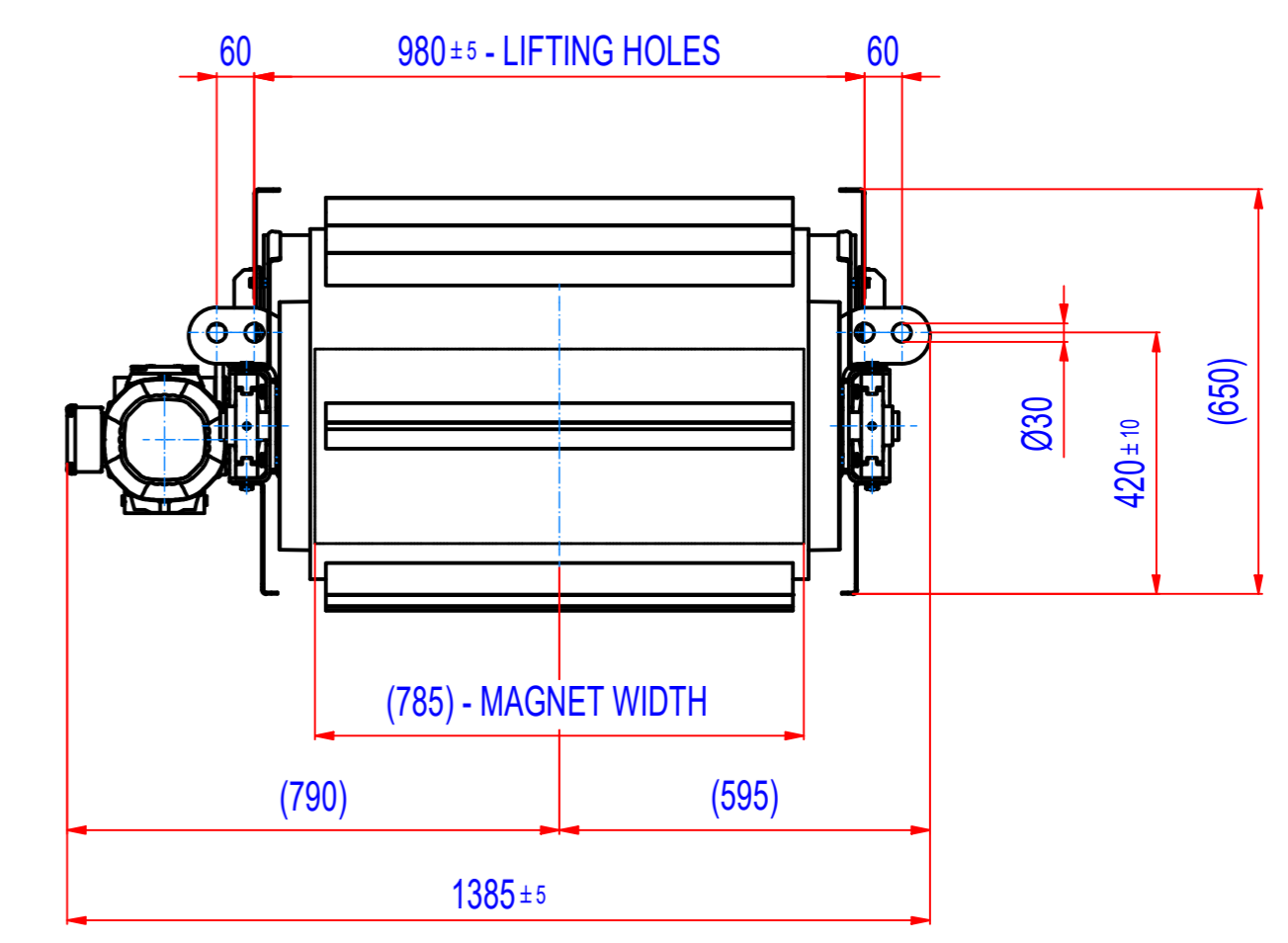
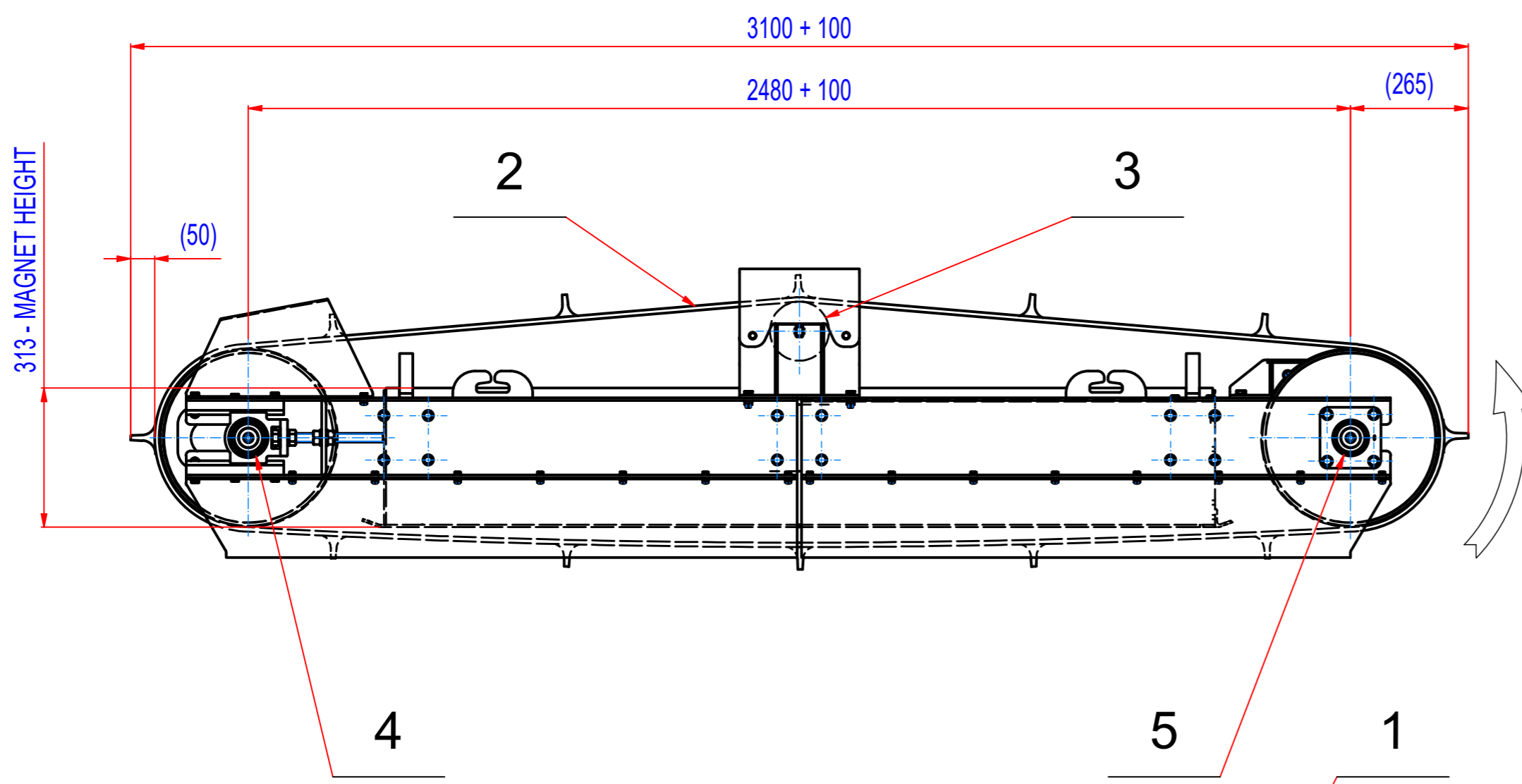

- GEARED BOX SEW SA67/TDRN100L4; i=20,37 (71RPM);
- MOTOR 230/400V; 3kW; 50Hz; IP55
- ROLLER SPEED 71/min
- BELT SPEED 1,5m/s
- BELT EP500/4 5+2; LENGTH 6280, WIDTH 800;
- 12 CLEATS T50/10, WIDTH 750

POZ.	Č. SOUČÁSTI	POPIS	MATERIÁL	HMOT.	MN.
5	15_8700045	BEARINGS ASSEMBLY INA PCJ 45		2,5	2
4	15_8600045	BEARINGS ASSEMBLY INA PTUE 45		2,7	2
3	1510_00055	PLAIN ROLLER d=133, L=950, 6306		20,1	1
2	45_4080063	BELT EP 500/4 5+2, W=800, L=6280	RUBBER	73	1
1	M030007116	SEW SA67/TDRN100L4, 3kW, i=20,37 (71 RPM)		64	1

Sheet: <b>A2</b> Drawn: <b>EN</b> Date: <b>25.1.2019</b> Predecessor: <b>SEPB160034</b> Quick search: <b>XSPB 4</b> Description: <b>SPARE PARTS FOR ROFC160340</b>	Weight (kg): <b>2404.6</b>  © All rights reserved. Reproduction is not permitted without written permission of GOUDSMIT Magnetic Systems BV	General tolerance: <b>ISO 2768 - cL</b> Drawn according: <b>ISO268; ISO1101; ISO2553</b> Status: Customer reference number: Product key: <b>ROP-F4-C-160-W-G-L-B-B-NA</b> Part number: <b>ROFC160340_SP</b> Rev: <b>A</b>
---	---	---