

| REV | BY | DATE | DESCRIPTION |
|-----|----|------------|------------------|
| - | LF | 20.07.2019 | ORIGINAL DRAWING |

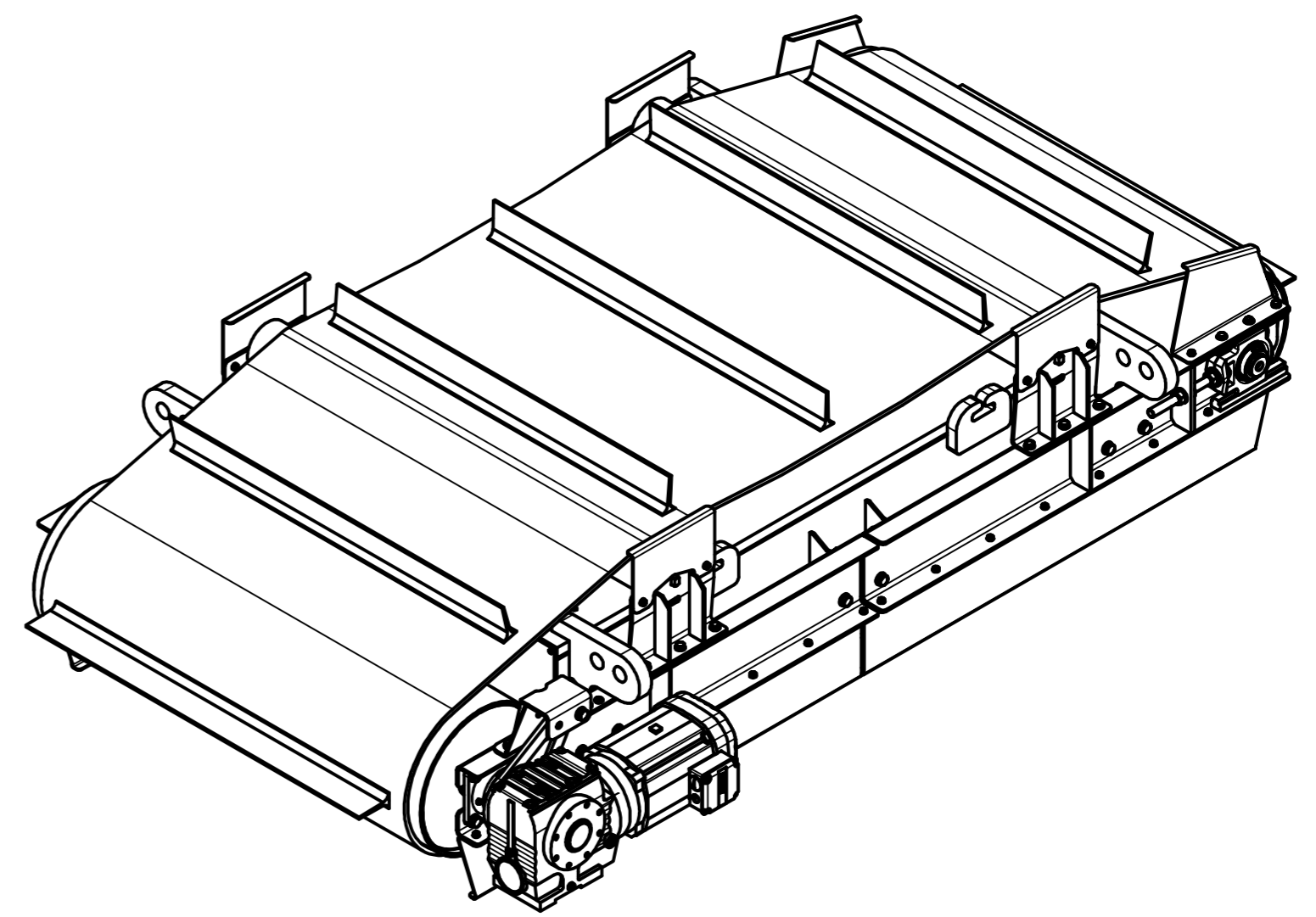
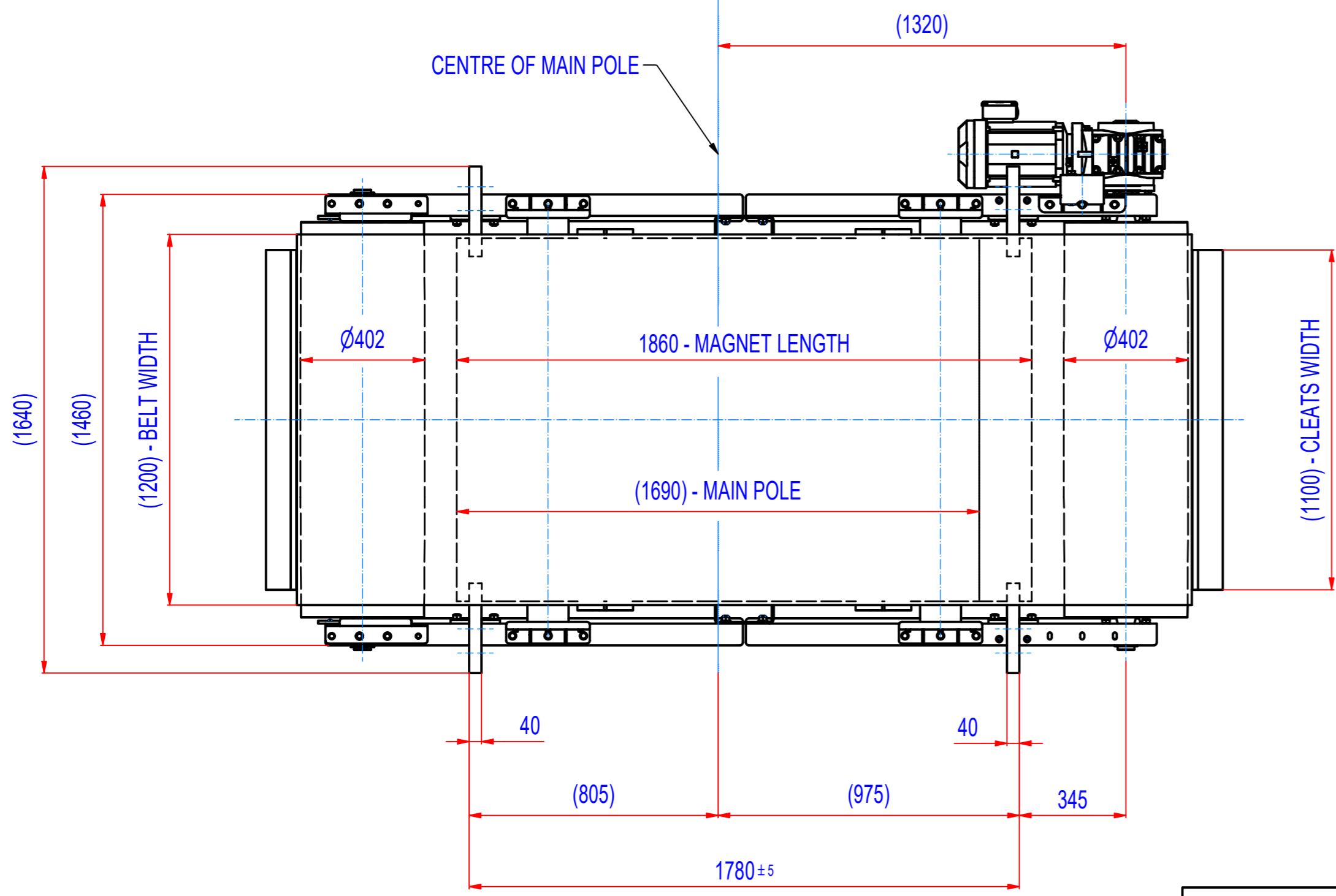
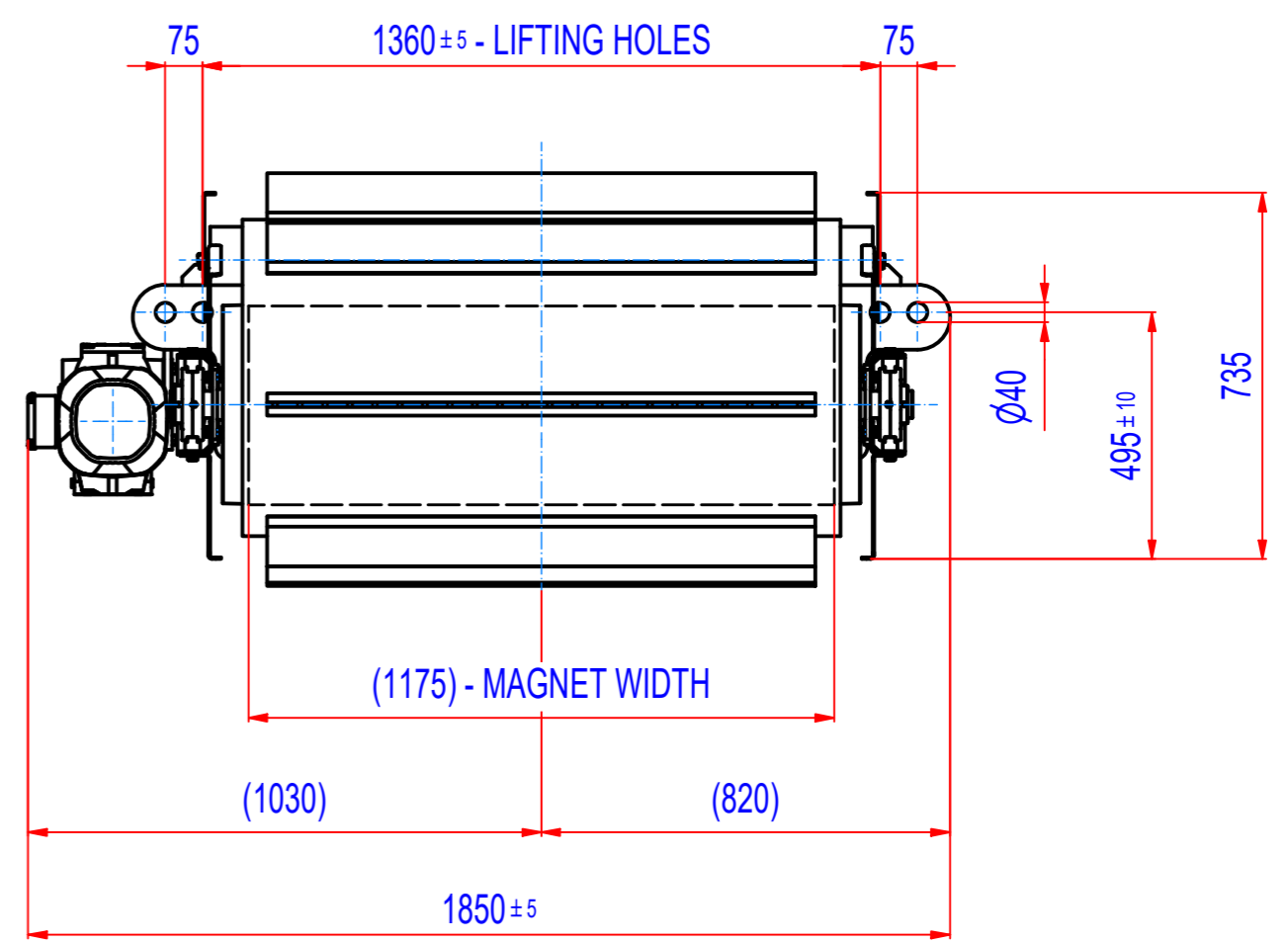
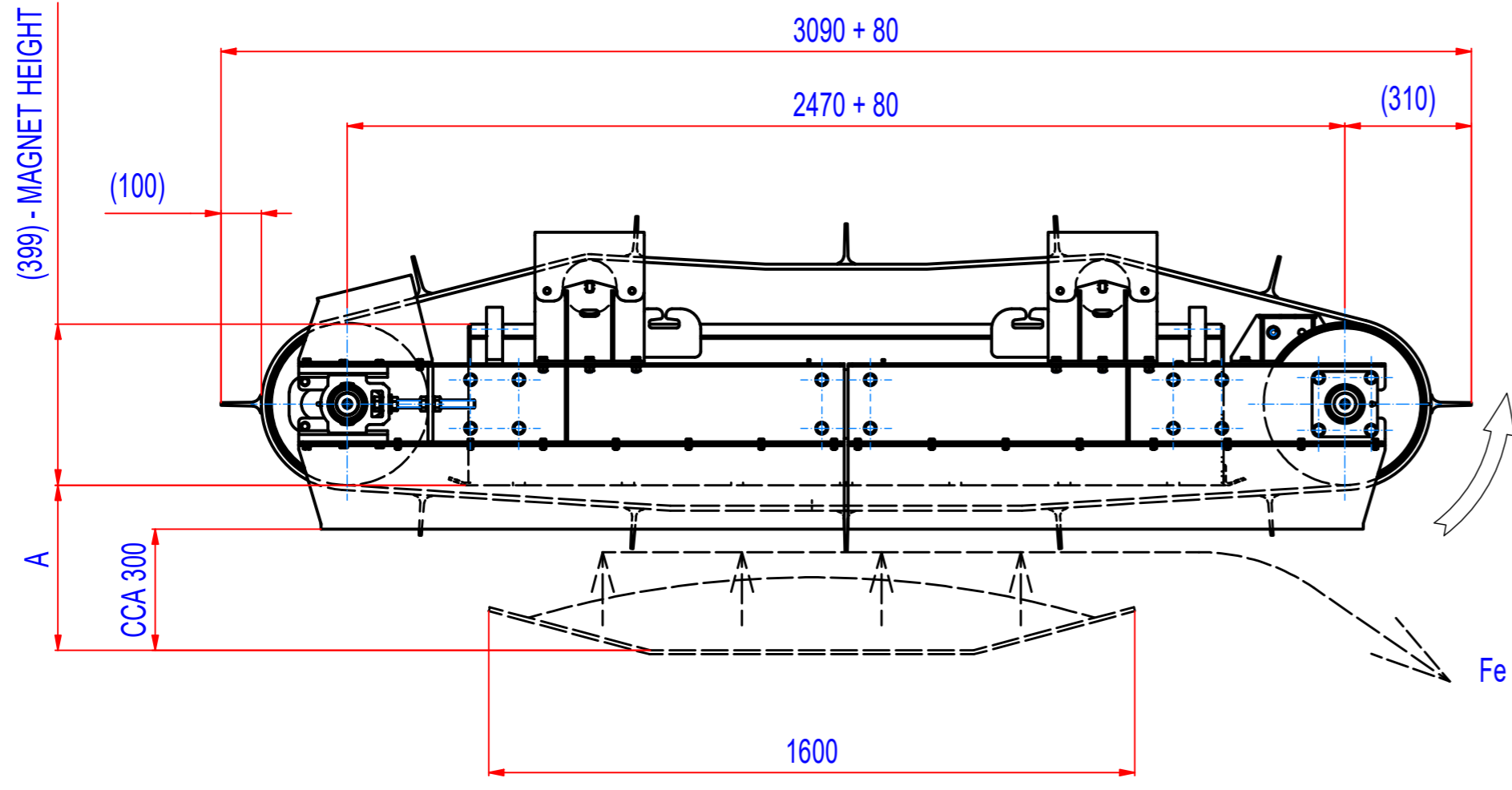

A = 460 mm - max. catch distance for rod Ø15, L=75 mm (VDE)
A = 410 mm - 400 Gs

- GEARED BOX SEW SA77/T DRN112M4, i=20,99 (70RPM), MOTOR 230/400V, 4kW, 50Hz, IP55
- DRUM SPEED 70/min
- BELT SPEED 1,45 m/s
- BELT EP500/4 5+2, LENGTH 6300, WIDTH 1200, 12 CLEATS T100/10, WIDTH 1100

| | | |
|--|---|---|
| Sheet: A2 | Extra info: | General tolerance: ISO 2768 - cL |
| Drawn: LF | Weight (kg): 4427.5 | Drawn according: ISO268; ISO1101; ISO2553 |
| Date: 20.7.2019 | | Status: |
| Predecessor: SEPB160036 | | Customer reference number: |
| Quick search: XSPB 6 | © All rights reserved. Reproduction is not permitted without written permission of GOUDSMIT Magnetic Systems BV | Product key: ROP-F6-C-160-W-G-L-B-B-NA |
| Description: Overband separator, Ferrite, Siza 6, W1600, Cross | | Part number: ROFC160360 |