

REV	BY	DATE	DESCRIPTION
-	LF	20.07.2019	ORIGINAL DRAWING
			25.02.2023 - REDUCTION IN THE NUMBER OF SPARE PARTS

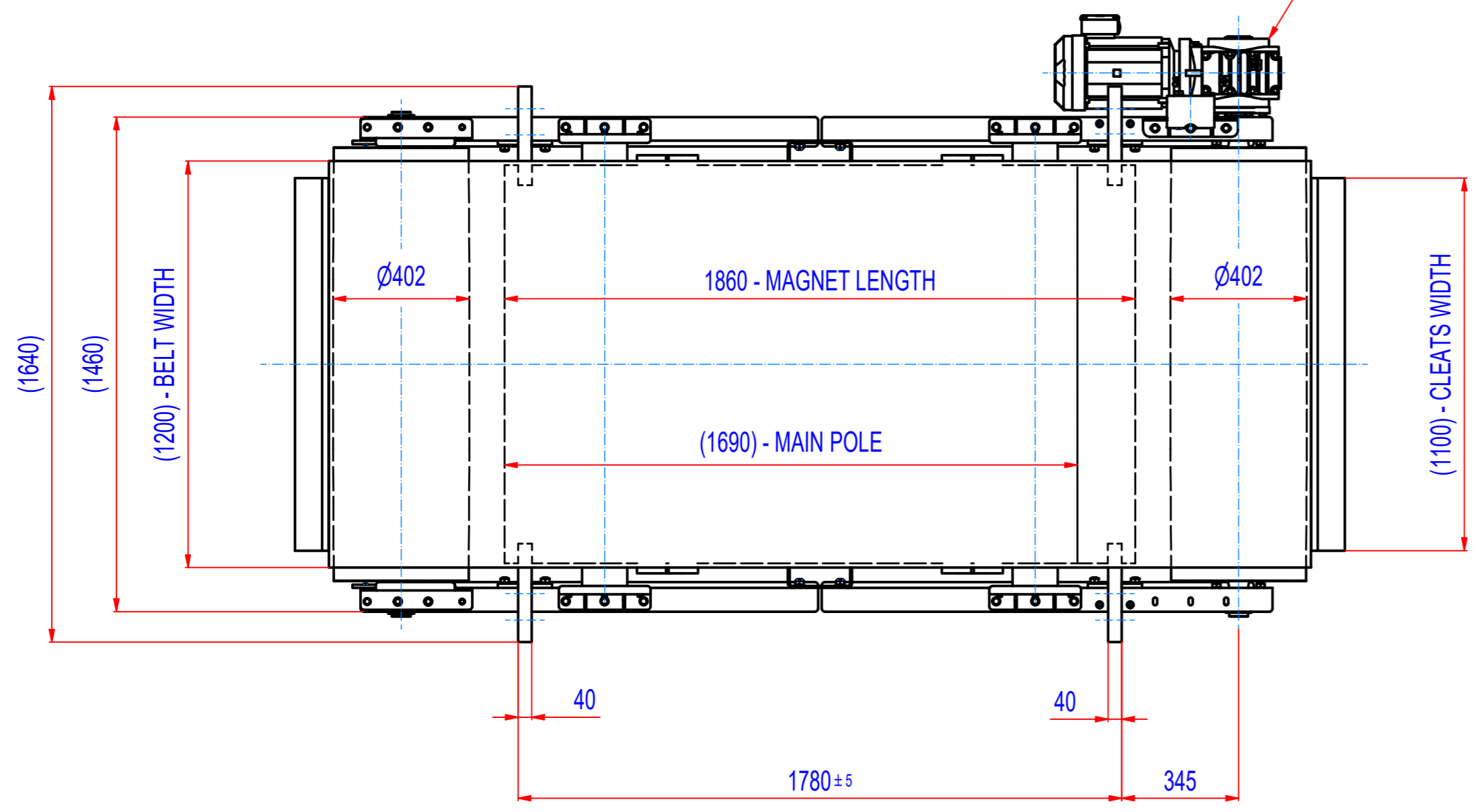
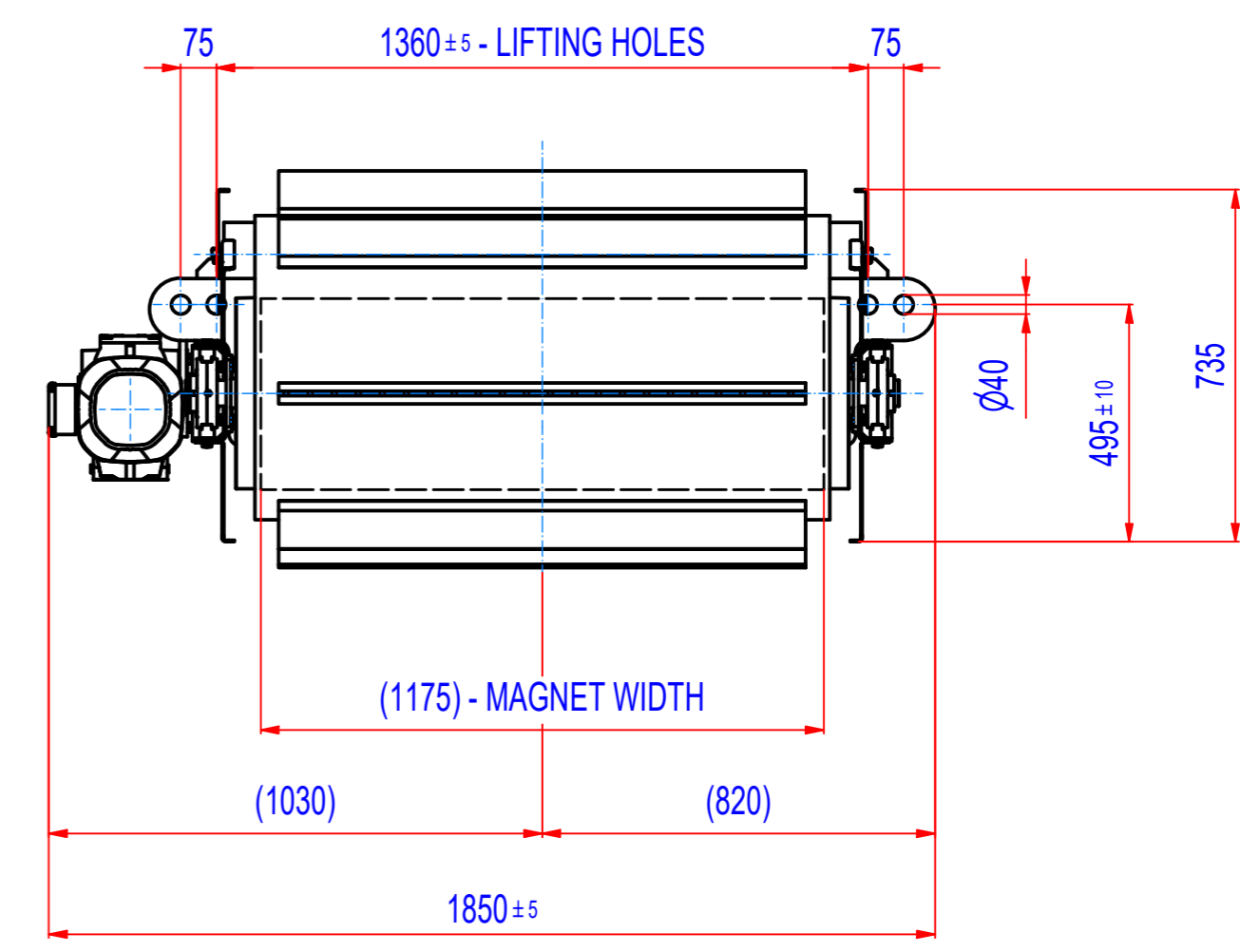
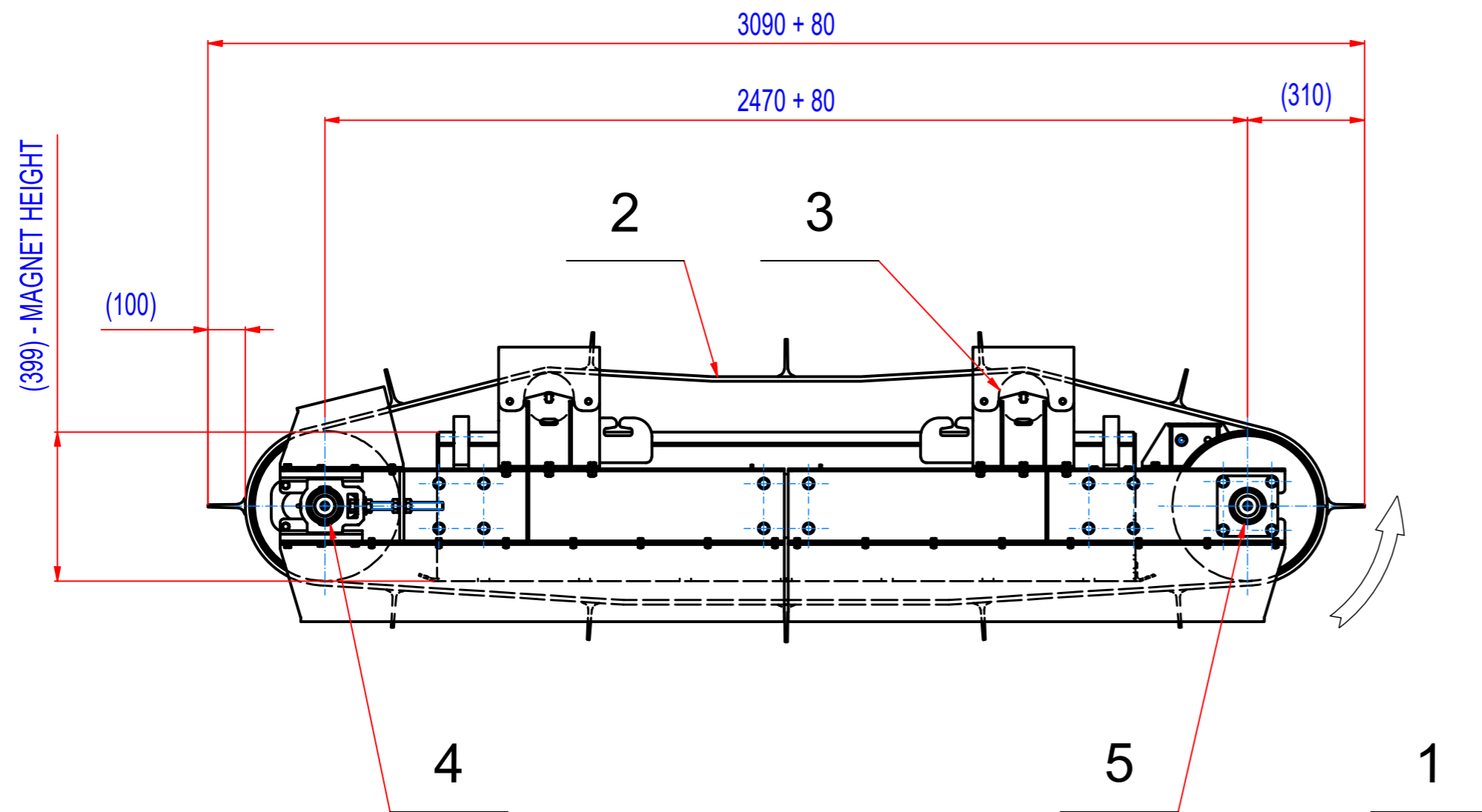

- GEARED BOX SEW SA77/T DRN112M4, i=20,99 (70RPM),  
 MOTOR 230/400V, 4kW, 50Hz, IP55  
 - DRUM SPEED 70/min  
 - BELT SPEED 1,45 m/s  
 - BELT EP500/4 5+2, LENGTH 6300, WIDTH 1200,  
 12 CLEATS T100/10, WIDTH 1100

POZ.	Č. SOUČÁSTI	POPIS	MATERIÁL	HMOT.	MN.
5	15_8700055	BEARINGS ASSEMBLY INA PCJ 55		3,5	2
4	15_8600057	BEARINGS ASSEMBLY INA PTUE 55		4	2
3	1510_00053	PLAIN ROLLER d=133, L=1330		27	2
2	45_4120030	BELT EP500/4 5+2, W=1200, L=6300	RUBBER	131	1
1	MO40007007	SEW SA77/TDRN112M4, 4kW, i=20,99 (70RPM)		95	1

Sheet: A2 Drawn: LF Date: 20.7.2019 Predecessor: SEPB160036 Quick search: XSPB 6 Description: SPARE PARTS FOR ROFC160360	Weight (kg): 4427.5  © All rights reserved. Reproduction is not permitted without written permission of GOUDSMIT Magnetic Systems BV	Extra info: General tolerance: ISO 2768 - cL Drawn according: ISO268; ISO1101; ISO2553 Status: Customer reference number: Product key: ROP-F6-C-160-W-G-L-B-B-NA Part number: ROFC160360_SP Rev: -
---	--	---