

REV	DATE	BY	DESCRIPTION
-	28.05.2019	LF	ORIGINAL DRAWING
			07.05.2023 - REDUCTION IN THE NUMBER OF SPARE PARTS

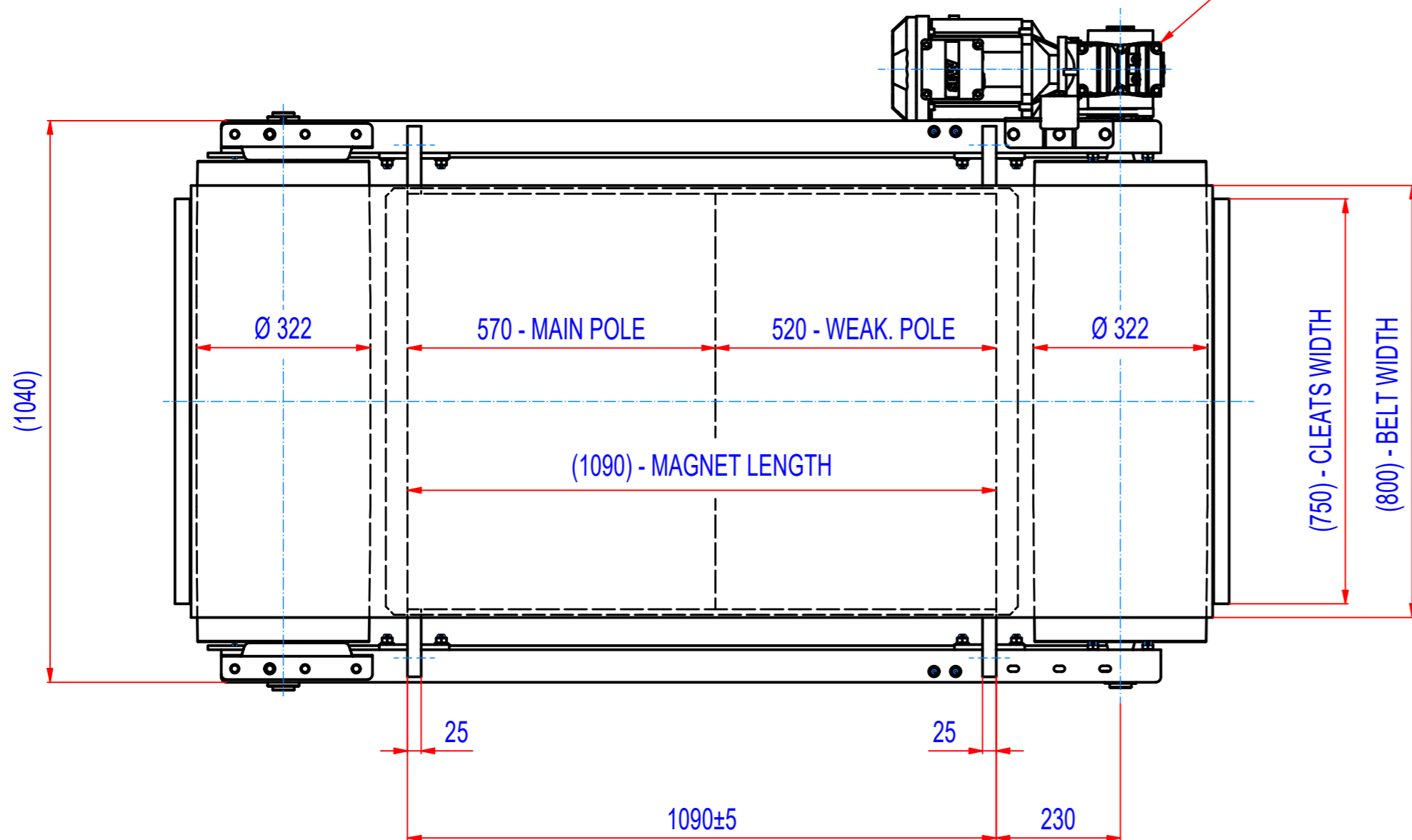
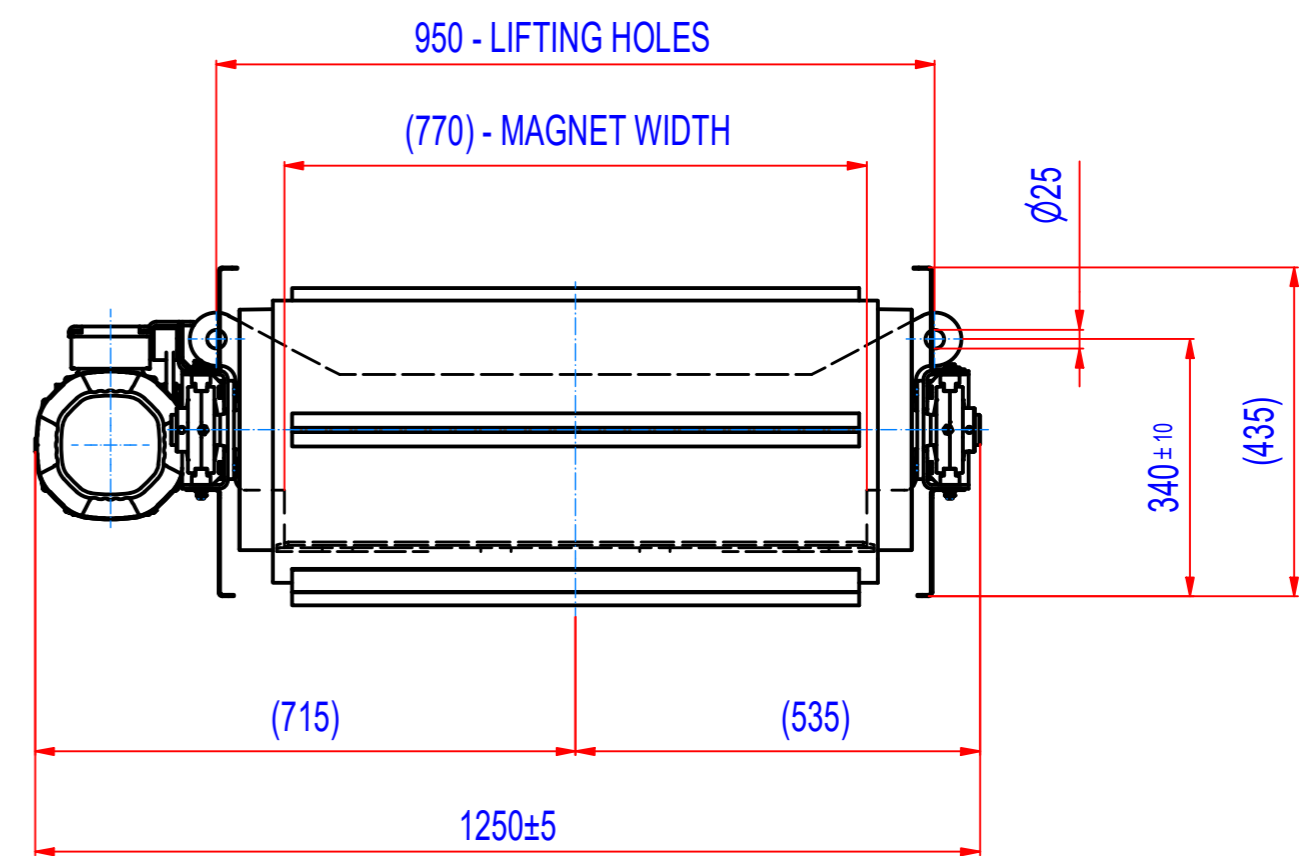
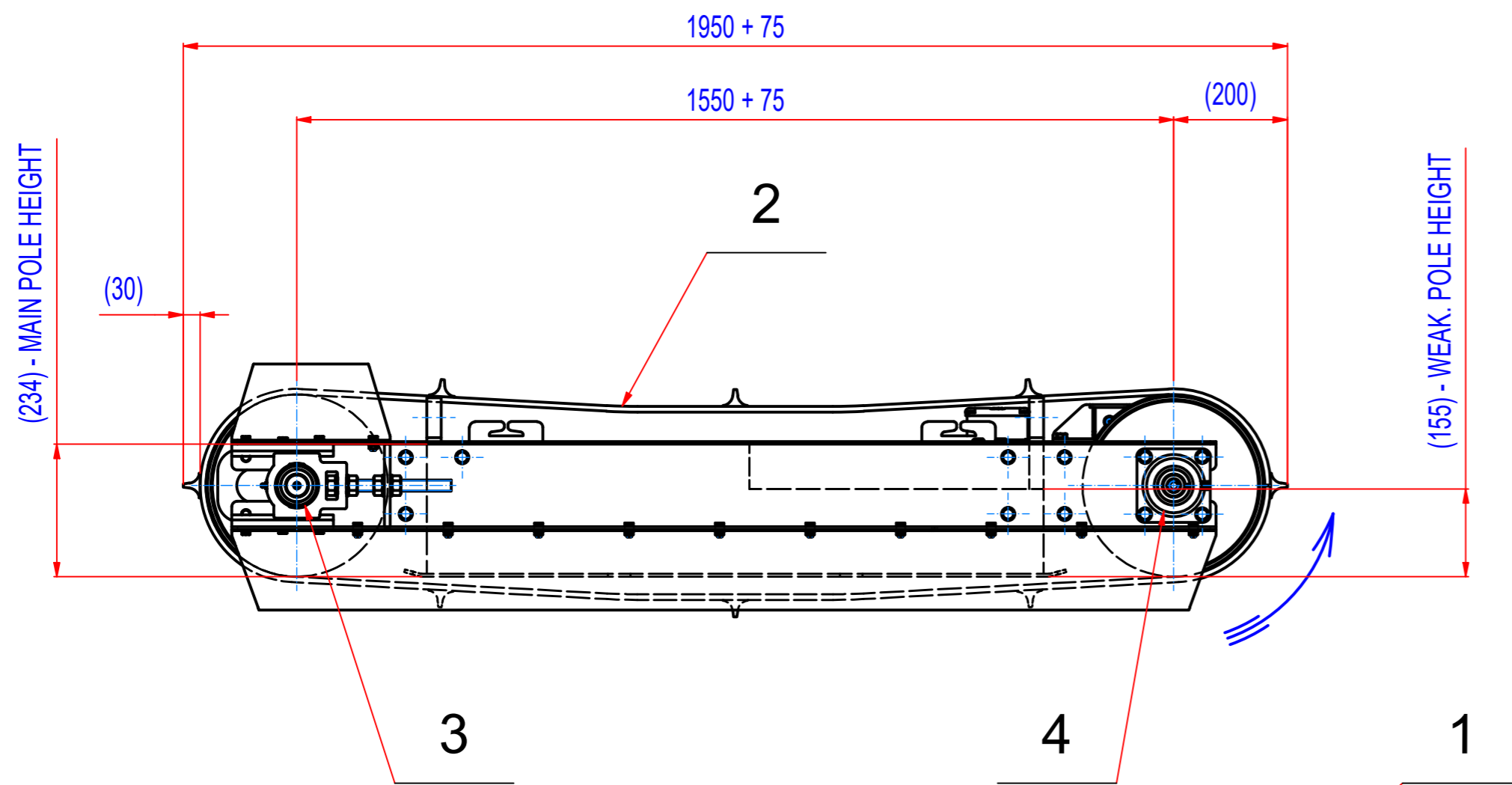

- GEARED BOX SEW SA57/TDRN100LS4, i=14,24 (102RPM),  
 MOTOR 2,2kW, 230/400V, 50Hz, IP55  
 - DRUM SPEED 102/min  
 - BELT SPEED 1,7 m/s  
 - BELT EP400/3 4+2, WIDTH 800, LENGTH 4170,  
 8 CLEATS T30/10, WIDTH 750

4	15_8700040	BEARINGS ASSEMBLY INA PCJ 40		1,9	2
3	15_8600040	BEARINGS ASSEMBLY INA PTUE 40		2,4	2
2	45_4080028	BELT EP400/3 4+2, W=800, L=4170	RUBBER	40	1
1	M022010003	SEW SA57/TDRN100LS4, 2,2kW, i=14,24 (102RPM)		42	1
POZ.	Č. SOUČÁSTI	POPIS	MATERIÁL	HMOT.	MN.

Sheet: <b>A2</b> Drawn: <b>LF</b> Date: <b>7.5.2023</b> Predecessor:	Weight (kg): <b>1105.4</b> <b>GOUDSMIT</b> <b>MAGNETICS</b> <small>© All rights reserved. Reproduction is not permitted without written permission of GOUDSMIT Magnetic Systems BV</small>	Extra info: General tolerance: <b>ISO 2768 - cL</b> Drawn according: <b>ISO268; ISO1101; ISO2553</b> Status: Customer reference number: Product key: <b>ROP-F3-I-080-W-G-L-B-B-NA</b> Part number: <b>ROFI080330_SP</b> Rev: -
Quick search: <b>XSPB 3</b> Description: <b>SPARE PARTS FOR ROFI080330</b>		