

REV	DATE	BY	DESCRIPTION
-	22.09.2018	LF	ORIGINAL DRAWING
			07.05.2023 - REDUCTION IN THE NUMBER OF SPARE PARTS

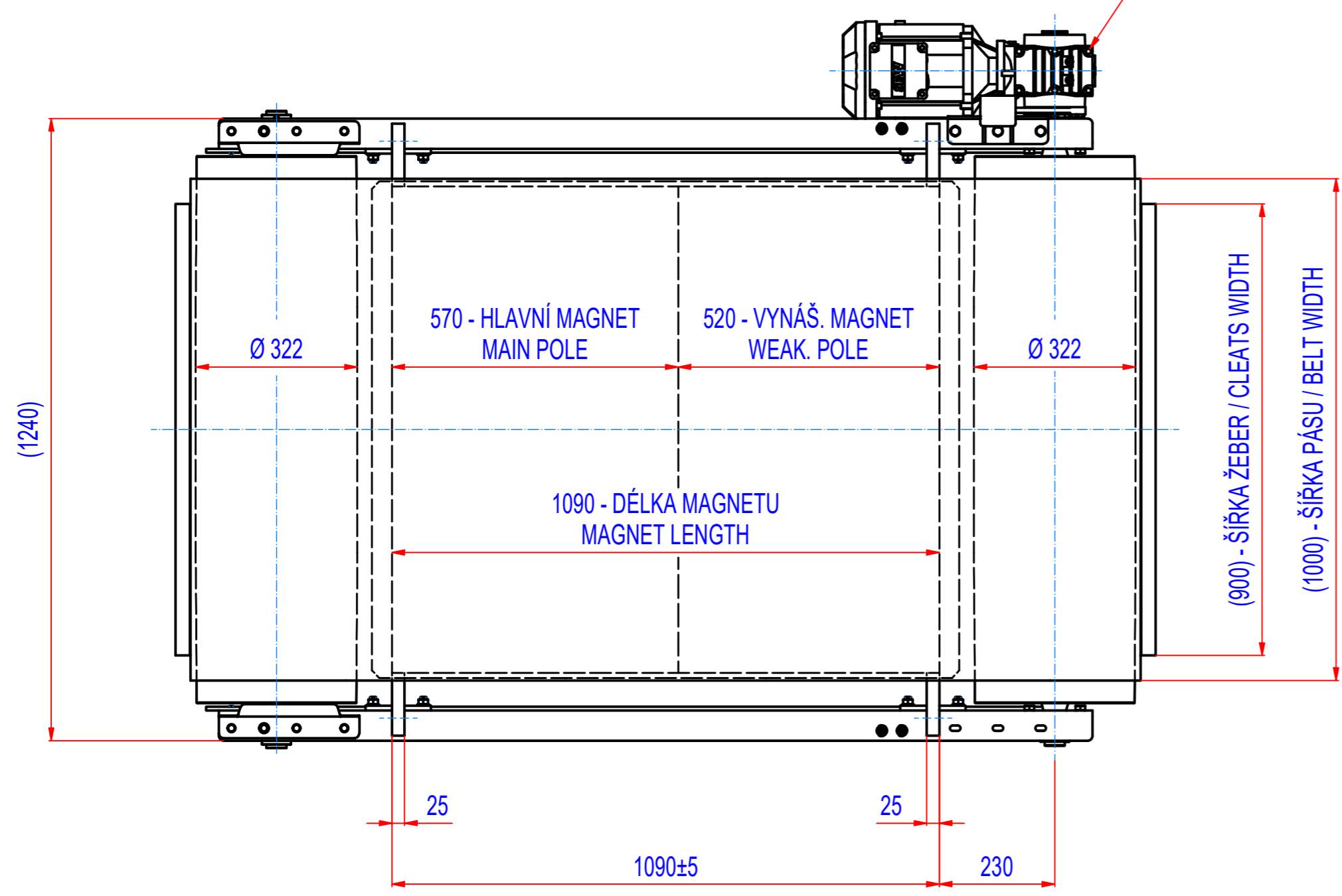
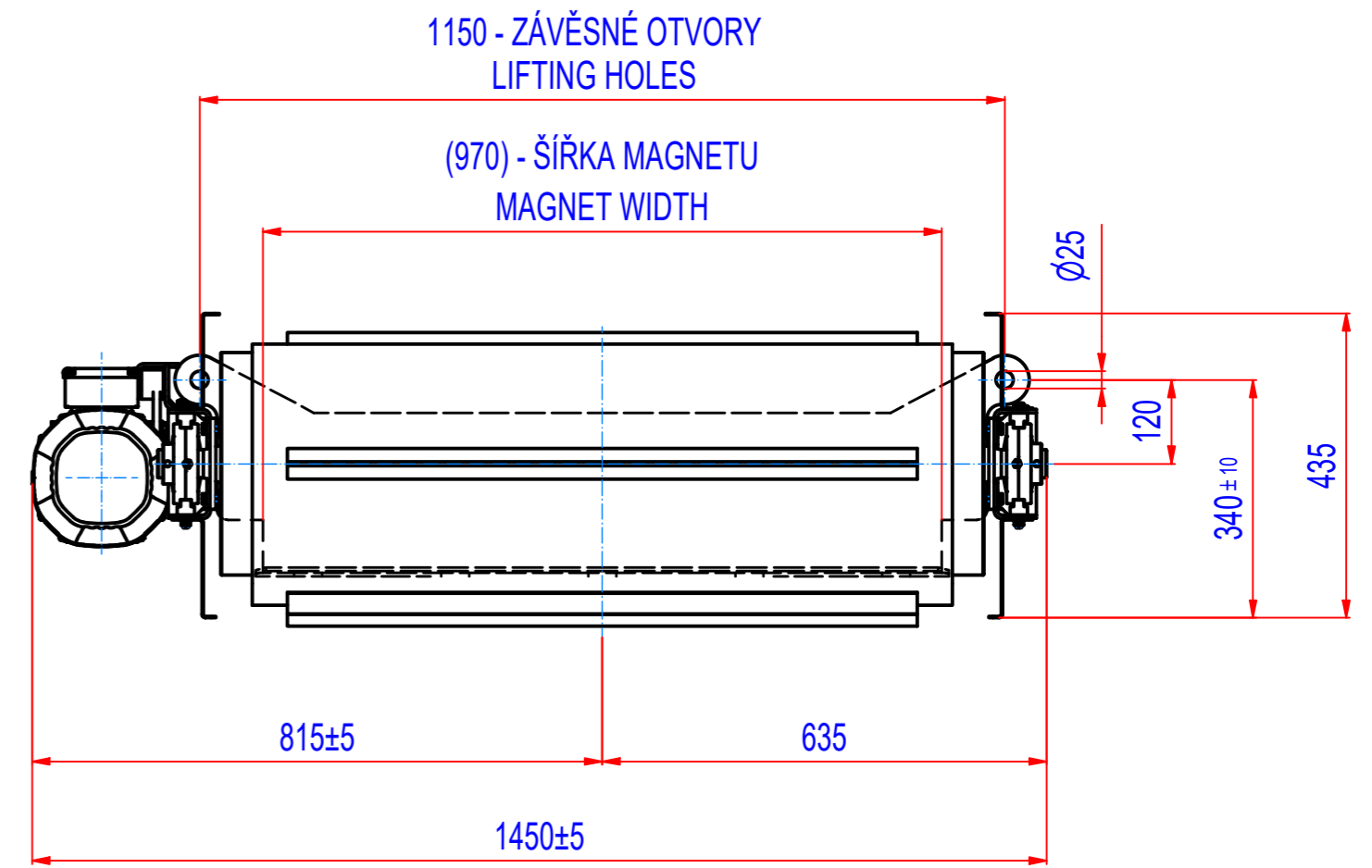
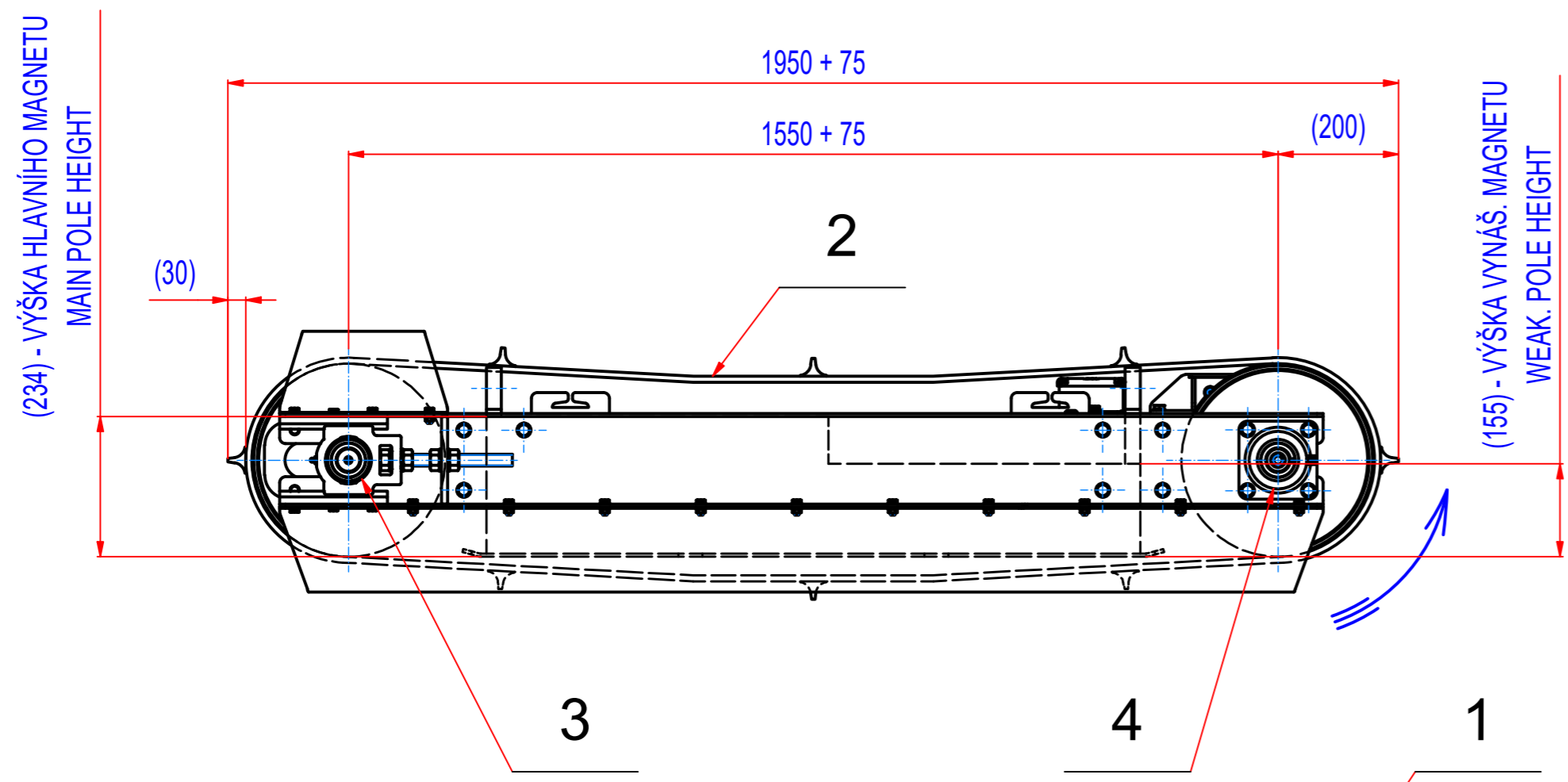

- POHON / GEARED BOX SEW SA57/TDRN100LS4, i=14,24 (102RPM), MOTOR 2,2kW, 230/400V, 50Hz, IP55
- OTÁČKY BUBNU / DRUM SPEED 102/min
- RYCHLOST PÁSU / BELT SPEED 1,7 m/s
- PÁS / BELT EP400/3 4+2, ŠÍŘKA / WIDTH 1000, DÉLKA / LENGTH 4170, 8 ŽEBER / CLEATS T30/10, ŠÍŘKA / WIDTH 900

4	15_8700040	BEARINGS ASSEMBLY INA PCJ 40		1,9	2
3	15_8600040	BEARINGS ASSEMBLY INA PTUE 40		2,4	2
2	45_4100018	BELT EP400/3 4+2, W=1000, L=4170	RUBBER	42	1
1	M022010003	SEW SA57/TDRN100LS4, 2,2kW, i=14,24 (102RPM)		42	1
POZ.	Č. SOUČÁSTI	POPIS	MATERIÁL	HMOT.	MN.

Sheet: A2	Extra info:	General tolerance: ISO 2768 - cL
Drawn: LF	Weight (kg): 1340.3	Drawn according: ISO268; ISO1101; ISO2553
Date: 22.9.2018		Status:
Predecessor:		Customer reference number:
Quick search: XSPB 3	© All rights reserved. Reproduction is not permitted without written permission of GOUDSMIT Magnetic Systems BV	Product key: ROP-F3-I-100-W-G-L-B-B-NA
Description: SPARE PARTS FOR ROFI100330		Part number: ROFI100330_SP