

REV	DATE	BY	DESCRIPTION
-	01.10.2021	EN	OLD VAULT REF. ROFI100340 rev.B
A	01.10.2021	EN	CLEATS 50 INSTEAD 100mm

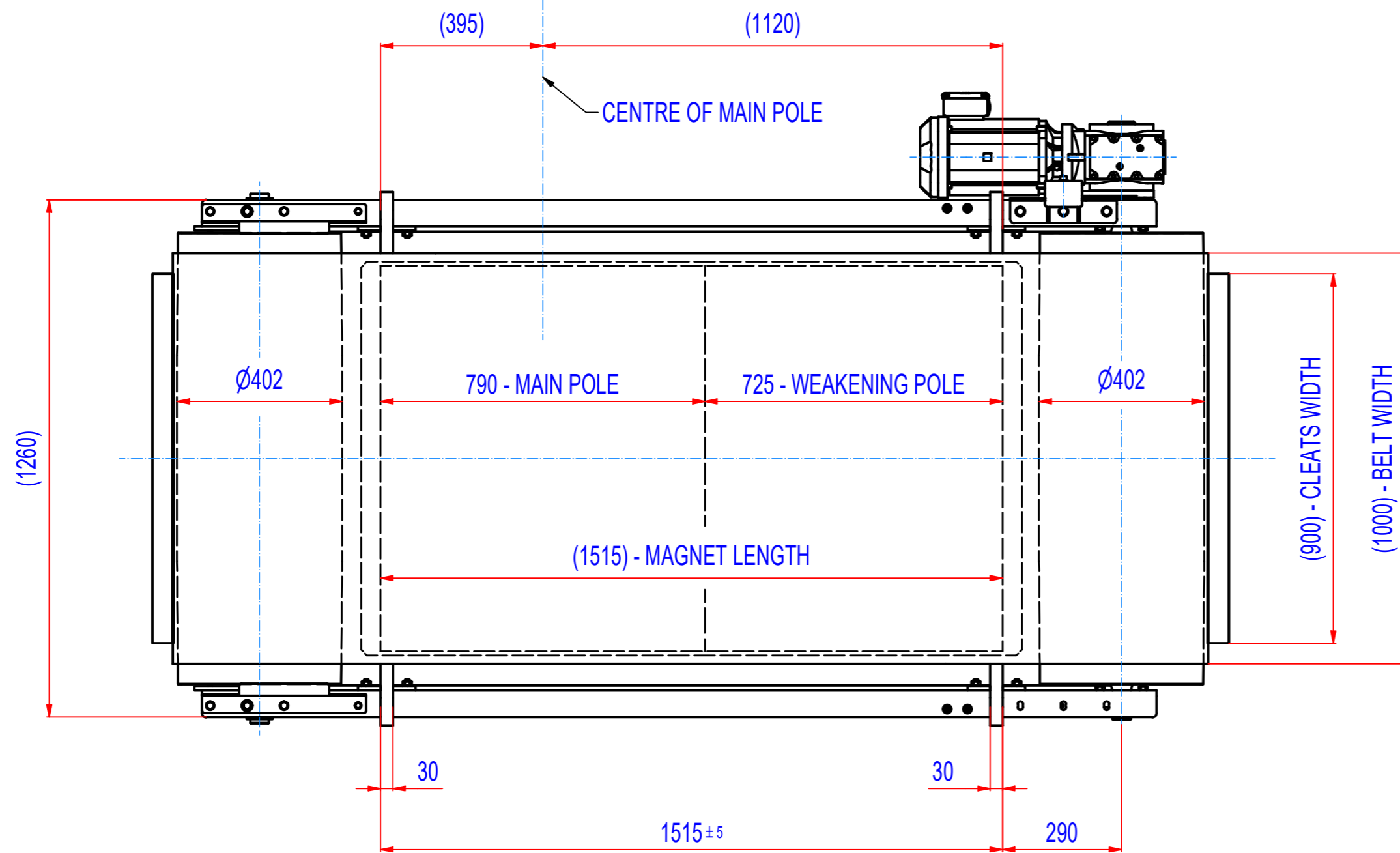
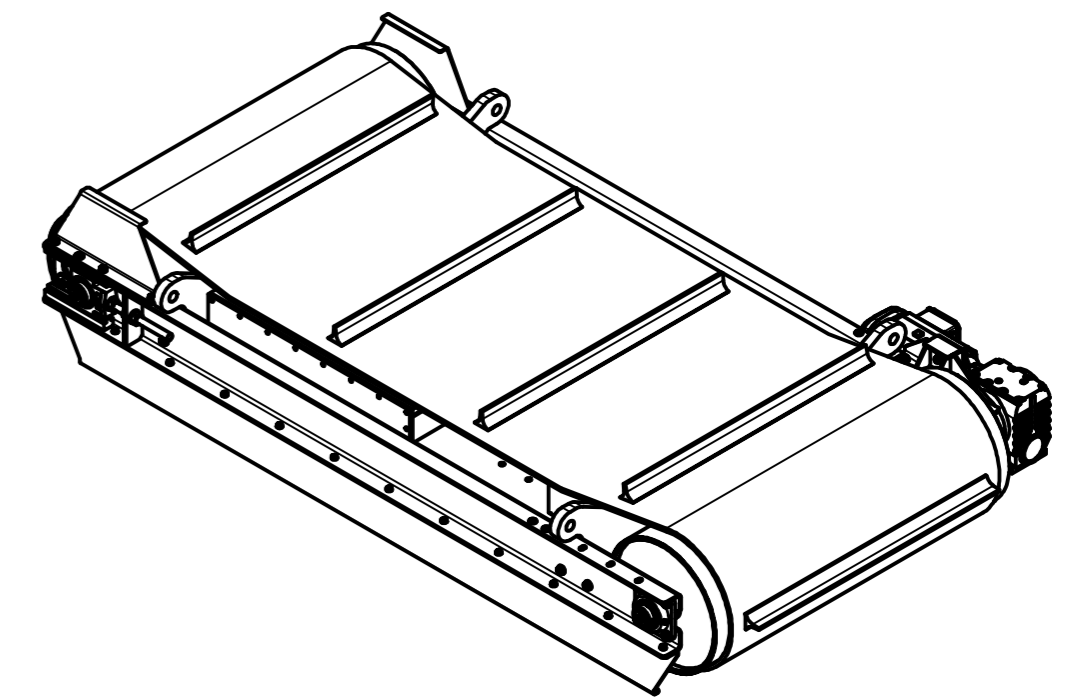
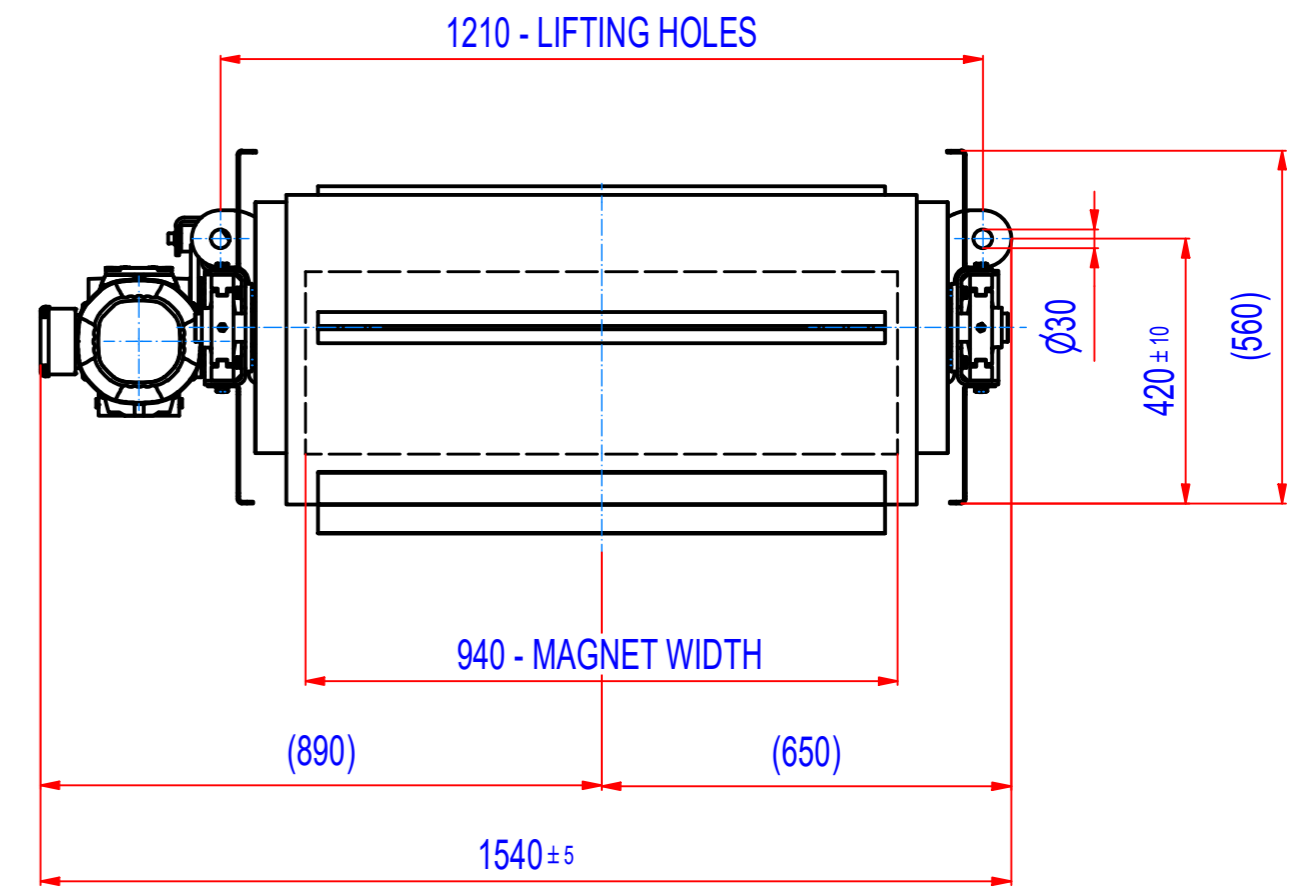
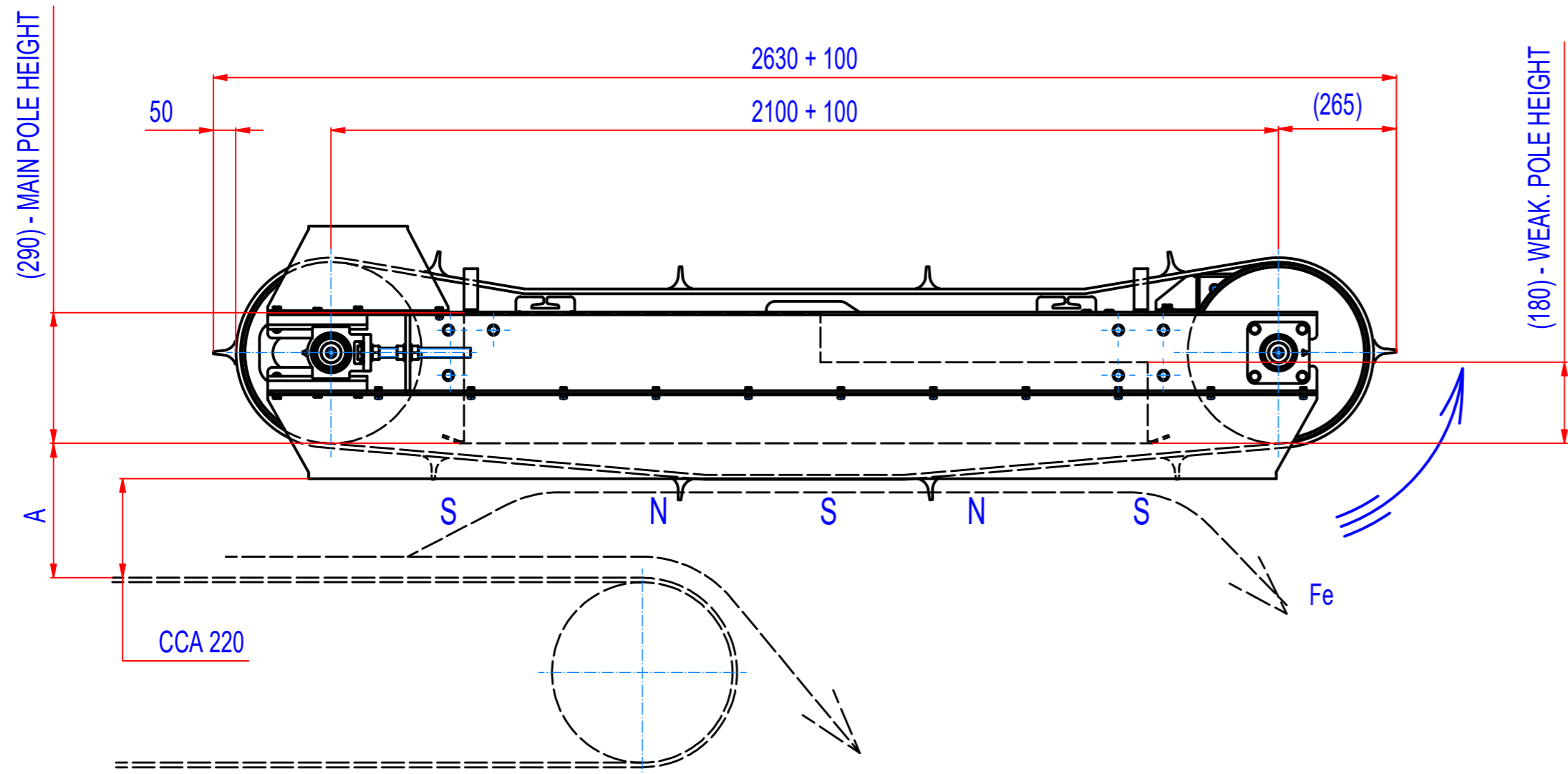

- GEARED BOX SEW SA67/TDRN100L4, i=20,37 (71RPM), MOTOR 3kW, 230/400V, 50Hz, IP55
- DRUM SPEED 71/min
- BELT SPEED 1,5 m/s
- BELT EP500/4 5+2, WIDTH 1000, LENGTH 5520, 10 CLEATS T50/10, WIDTH 900

A = 360 mm - max. catch distance for rod Ø15, L=75 mm (VDE)  
A = 295 mm - 400 Gs

Sheet: A2	Extra info:	General tolerance: ISO 2768 - cL
Drawn: EN	Weight (kg): 2013.6	Drawn according: ISO268; ISO1101; ISO2553
Date: 3.11.2022		Status:
Predecessor:		Customer reference number:
Quick search: XSPB 4	© All rights reserved. Reproduction is not permitted without written permission of GOUDSMIT Magnetic Systems BV	Product key: ROP-F4-I-100-W-G-L-B-B-NA
Description: Overband separator, Ferrite, Size 4, W1000, Inline		Part number: ROFI100340 Rev: A