

REV	BY	DATE	DESCRIPTION
-	LF	11.06.2018	ORIGINAL DRAWING
			10.10.2023 - REDUCTION IN NUMBER OF SPARE PARTS
A	LF	21.10.2023	LIFTING HOLES d35 (WAS d30)

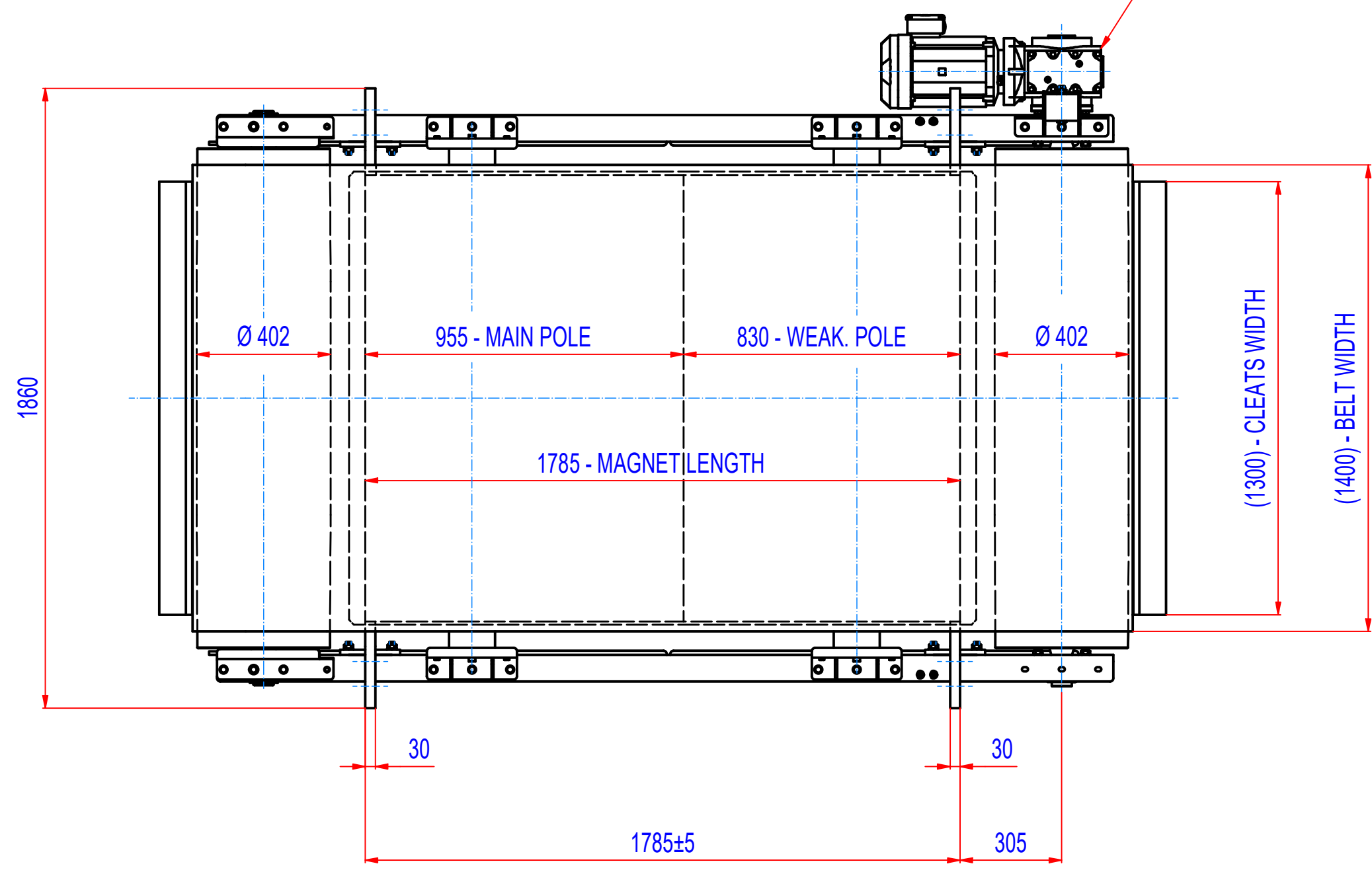
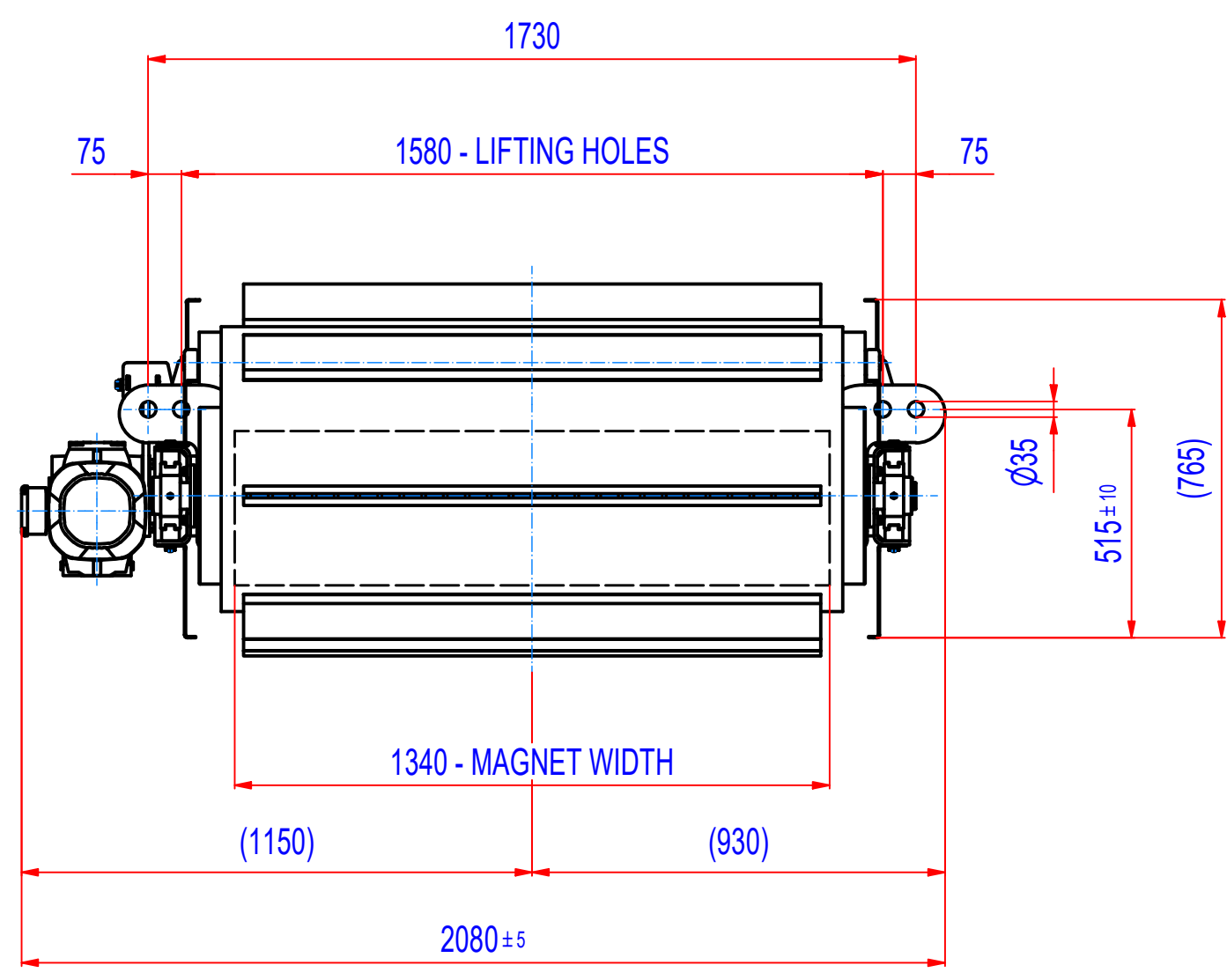
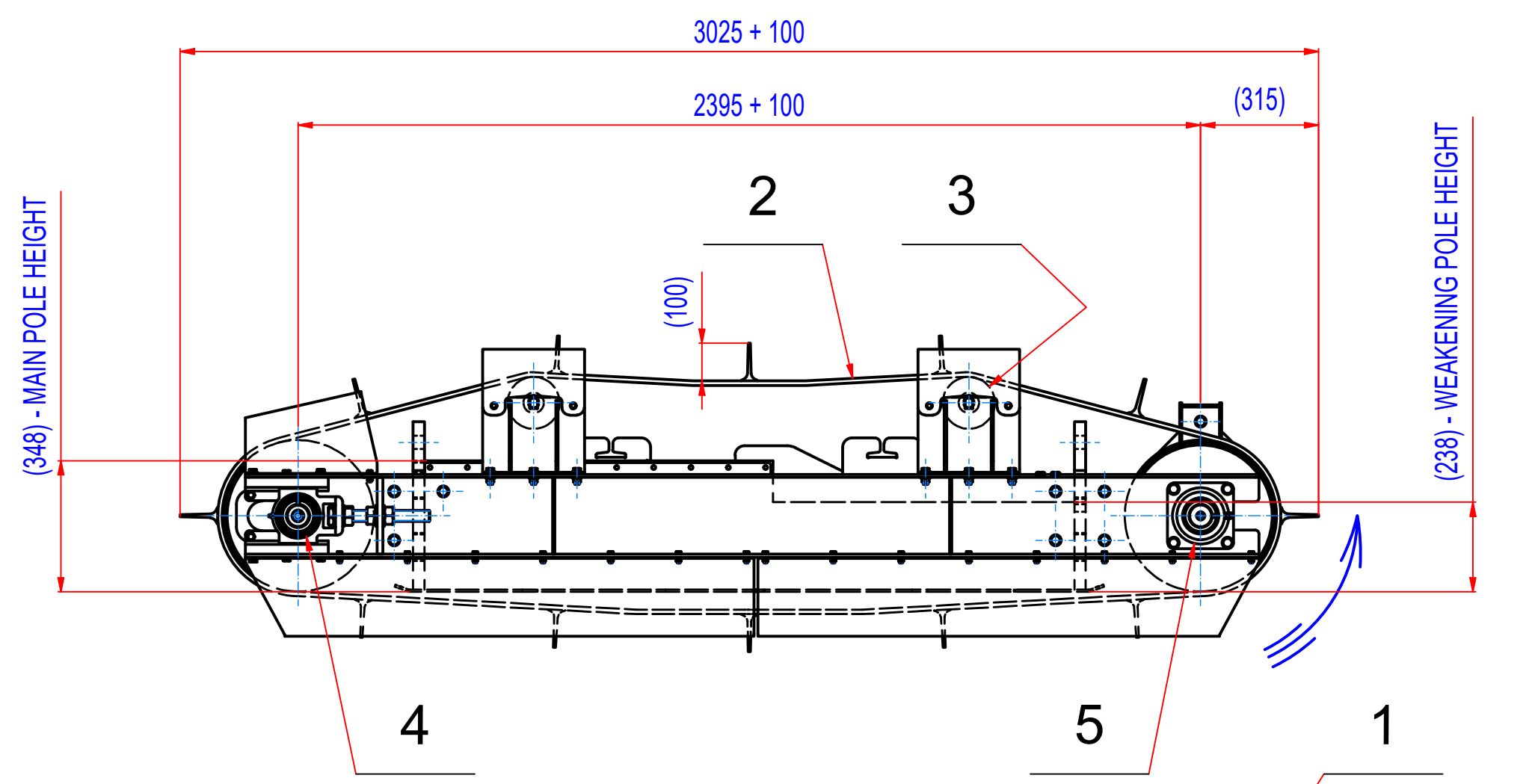

- GEARED BOX: SEW SA77/TDRN112M4, i=20,99 (70RPM),
 MOTOR 4kW, 230/400V, 50Hz, IP55
 - DRUM SPEED 70 /min
 - BELT SPEED 1,45 m/s
 - BELT EP500/4 5+2, WIDTH 1400, LENGTH 6150,
 12 CLEATS T100/10, WIDTH 1300

5	15_8700060	BEARINGS ASSEMBLY INA PCJ 60		4,1	2
4	15_8600060	BEARINGS ASSEMBLY INA PTUE 60		4,3	2
3	1510_00025	PLAIN ROLLER d=138, L=1500		32,5	2
2	45_4140011	BELT EP500/4 5+2, W=1400, L=6150	RUBBER	151	1
1	M040007012	SEW SA77/TDRN112M4, 4kW, i=20,99 (70RPM)		91,6	1
POZ.	Č. SOUČÁSTI	POPIS	MATERIÁL	HMOT.	MN.

Sheet: A2 Drawn: LF Date: 11.6.2018 Predecessor:	Extra info: © All rights reserved. Reproduction is not permitted without written permission of GOUDSMIT Magnetic Systems BV	General tolerance: ISO 2768 - cL Drawn according: ISO268; ISO1101; ISO2553 Status: Customer reference number: Product key: ROP-F5-I-140-W-G-L-B-B-NA Part number: ROFI140350_SP Rev: A
Quick search: XSPB 5		Description: SPARE PARTS FOR ROFI140350