

| REV | DATE | BY | DESCRIPTION |
|-----|------------|----|---|
| - | 13.06.2019 | EN | New Vault, old. rev. C, dimensions update |
| A | 05.09.2019 | LF | TOP ROLLERS TRANSROLL (WAS INTERROLL) |
| B | 22.01.2022 | LF | MOTOR IP55 (WAS IP54) |
| | | | 20.12.2023 - REDUCTION IN NUMBER OF SPARE PARTS |

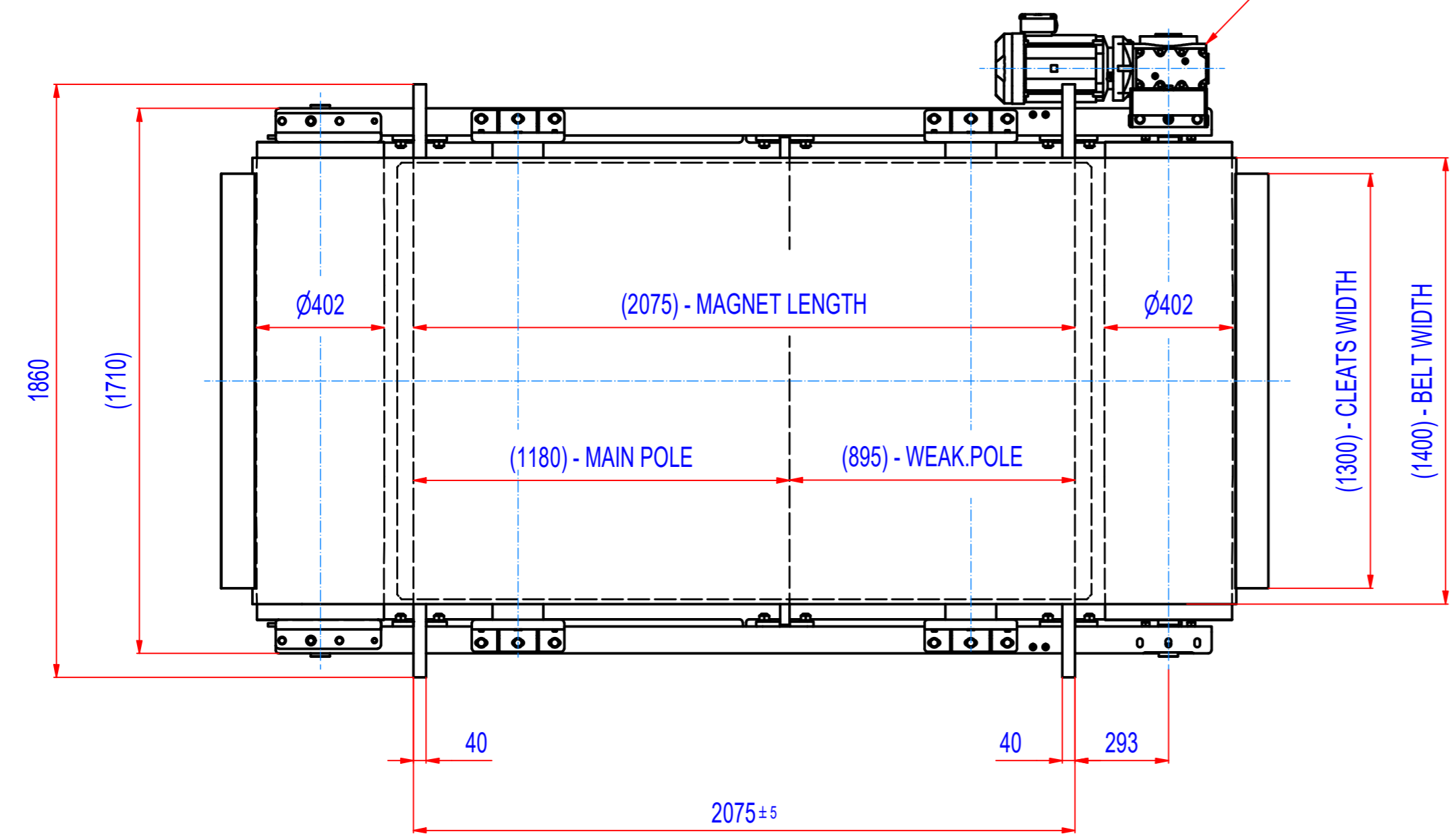
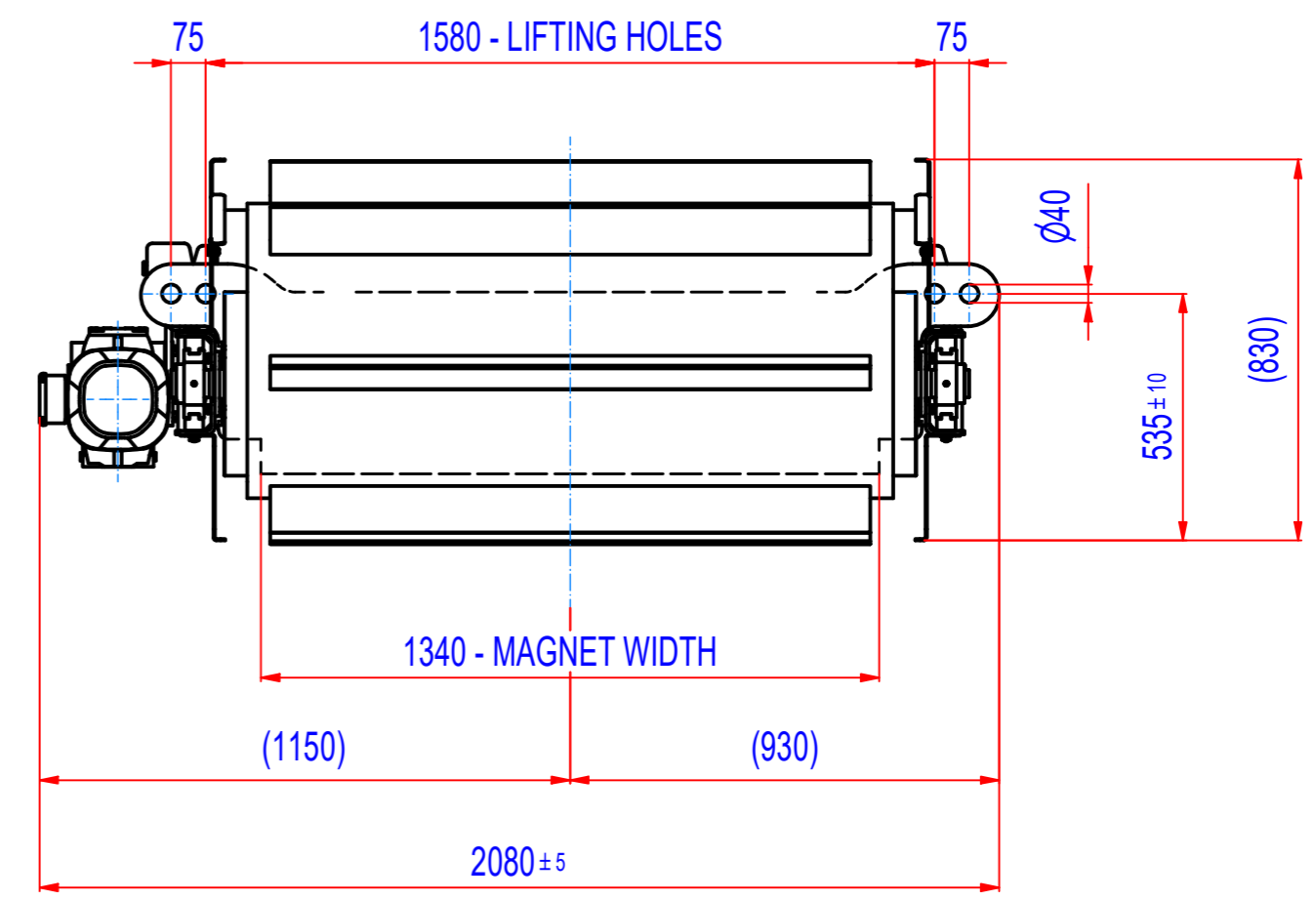
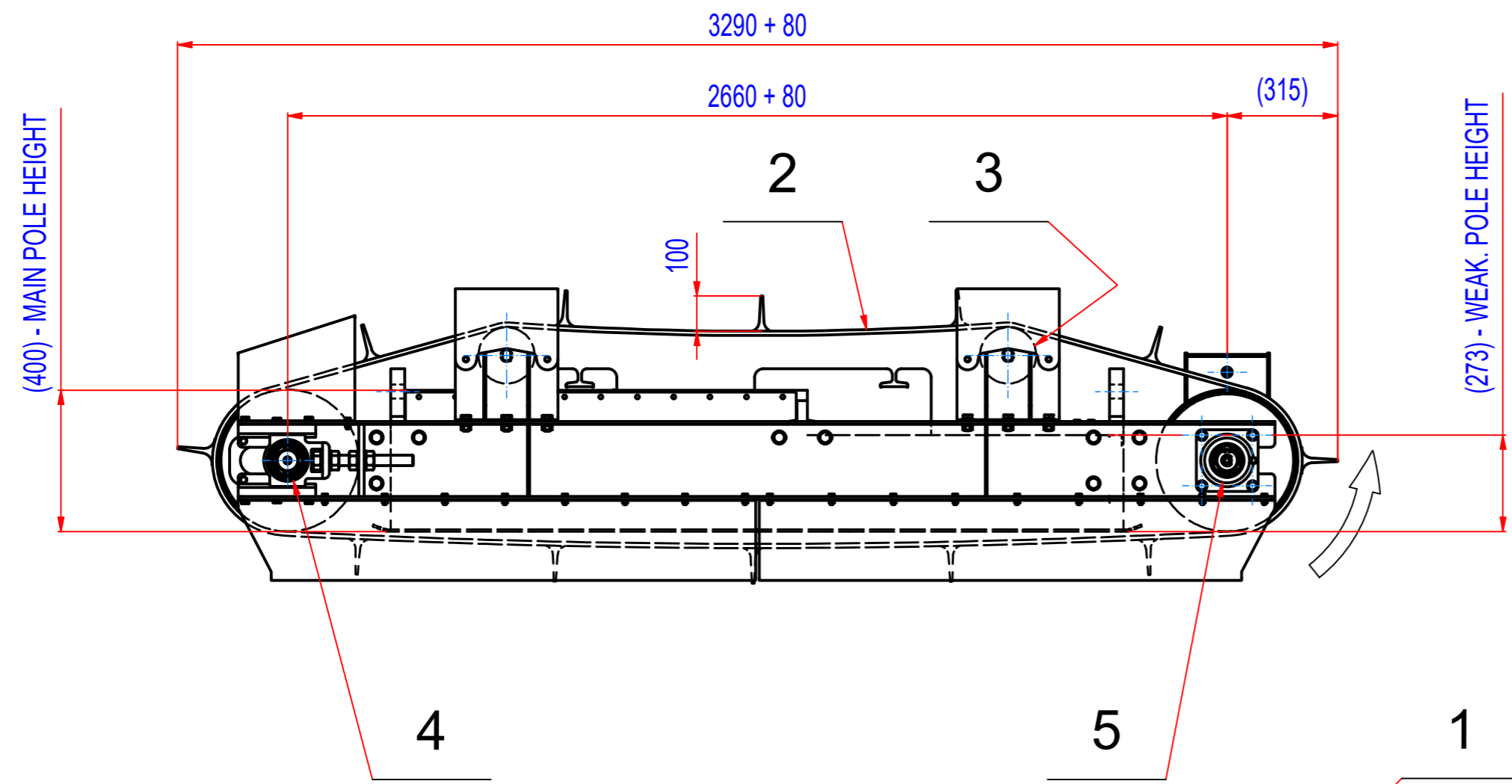

- GEARED BOX: SEW SA77/TDRN112M4, i=20,99 (70RPM),
 MOTOR 4kW, 230/400V, 50Hz, IP55
 - BELT SPEED 1,45 m/s
 - BELT EP500/4 5+2, WIDTH 1400, LENGTH 6700,
 12 CLEATS T100/10, WIDTH 1300

| POZ. | Č. SOUČÁSTI | POPIS | MATERIÁL | HMOT. | MN. |
|------|-------------|--|----------|-------|-----|
| 5 | 15_8700060 | BEARINGS ASSEMBLY INA PCJ 60 | | 4,1 | 2 |
| 4 | 15_8600060 | BEARINGS ASSEMBLY INA PTUE 60 | | 4,3 | 2 |
| 3 | 1510_00056 | PLAIN ROLLER 159x1530/6308 | | 42,8 | 2 |
| 2 | 45_4140014 | BELT EP 500/4 5+2, W=1400, L=6700 | RUBBER | 132 | 1 |
| 1 | M040007012 | SEW SA77/TDRN112M4, 4kW, i=20,99 (70RPM) | | 91,6 | 1 |

| | | |
|---|--|--|
| Sheet: A2 Drawn: EN Date: 20.12.2023 Predecessor: | Extra info: © All rights reserved. Reproduction is not permitted without written permission of GOUDSMIT Magnetic Systems BV | General tolerance: ISO 2768 - cL Drawn according: ISO268; ISO1101; ISO2553 Status: Customer reference number: Product key: ROP-F6-I-140-W-G-L-B-B-NA Part number: ROFI140360_SP Rev: B |
| Quick search: XSPB 6 Description: SPARE PARTS FOR ROFI140360 | | |