

REV	BY	DATE	DESCRIPTION
-	PH	12.01.2018	NEW STANDARD; REF: M73_000000

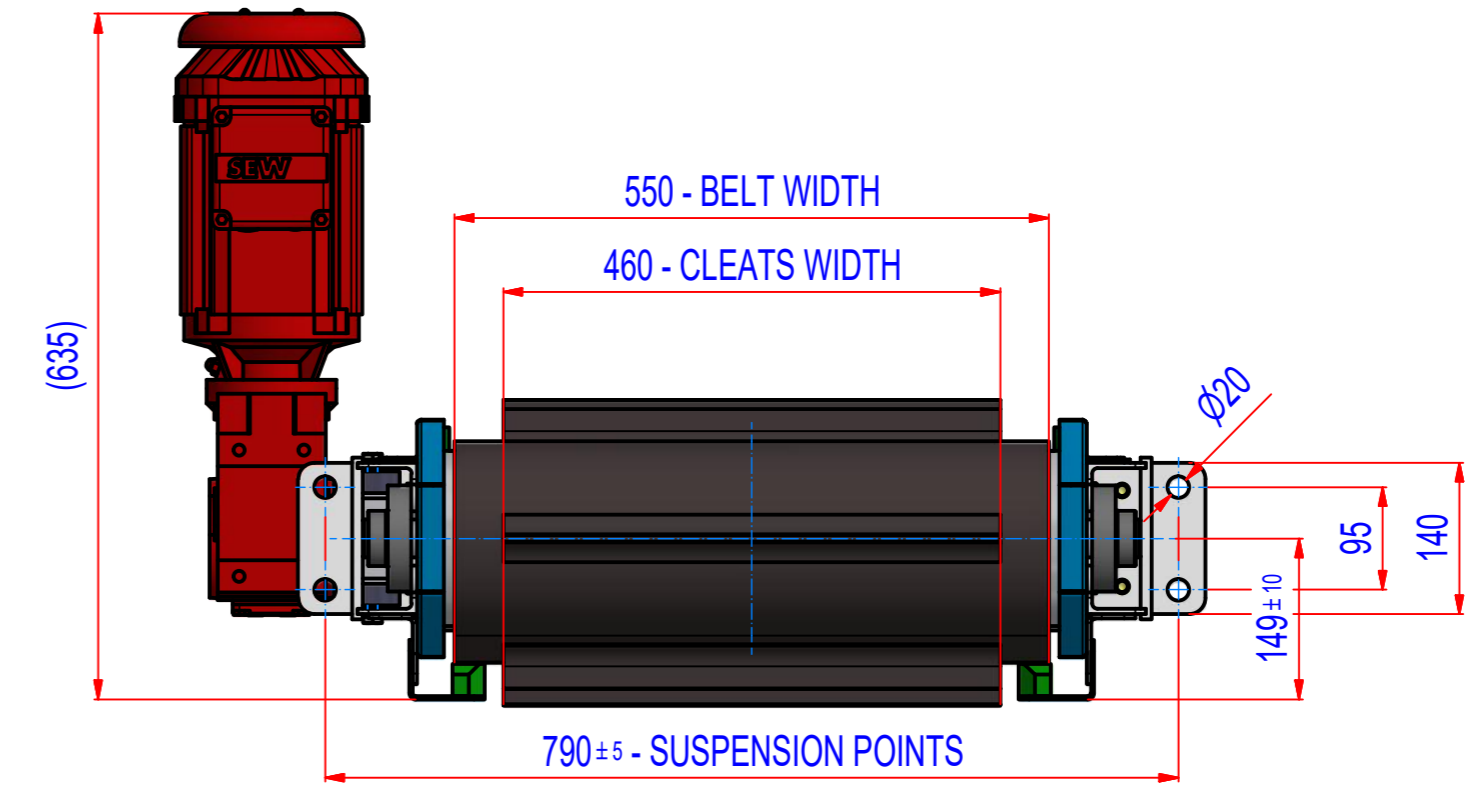

NOTE : MAGNET SHOULD BE INSTALLED BETWEEN IDLER ROLLERS.
ANY IDLER ROLLERS DIRECTLY BENEATH THE MAGNET SHOULD BE OF A NON-MAGNETIC MATERIAL.

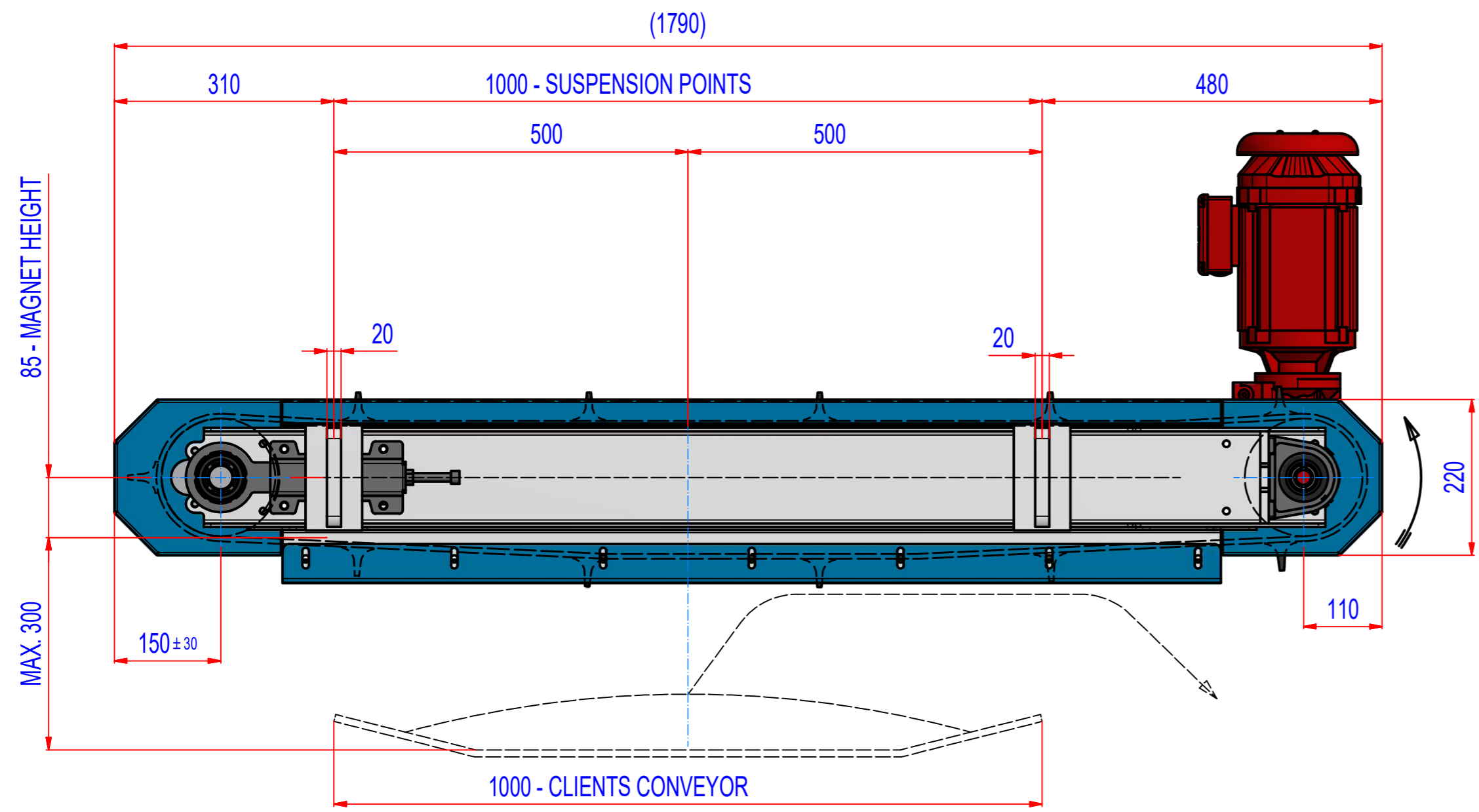
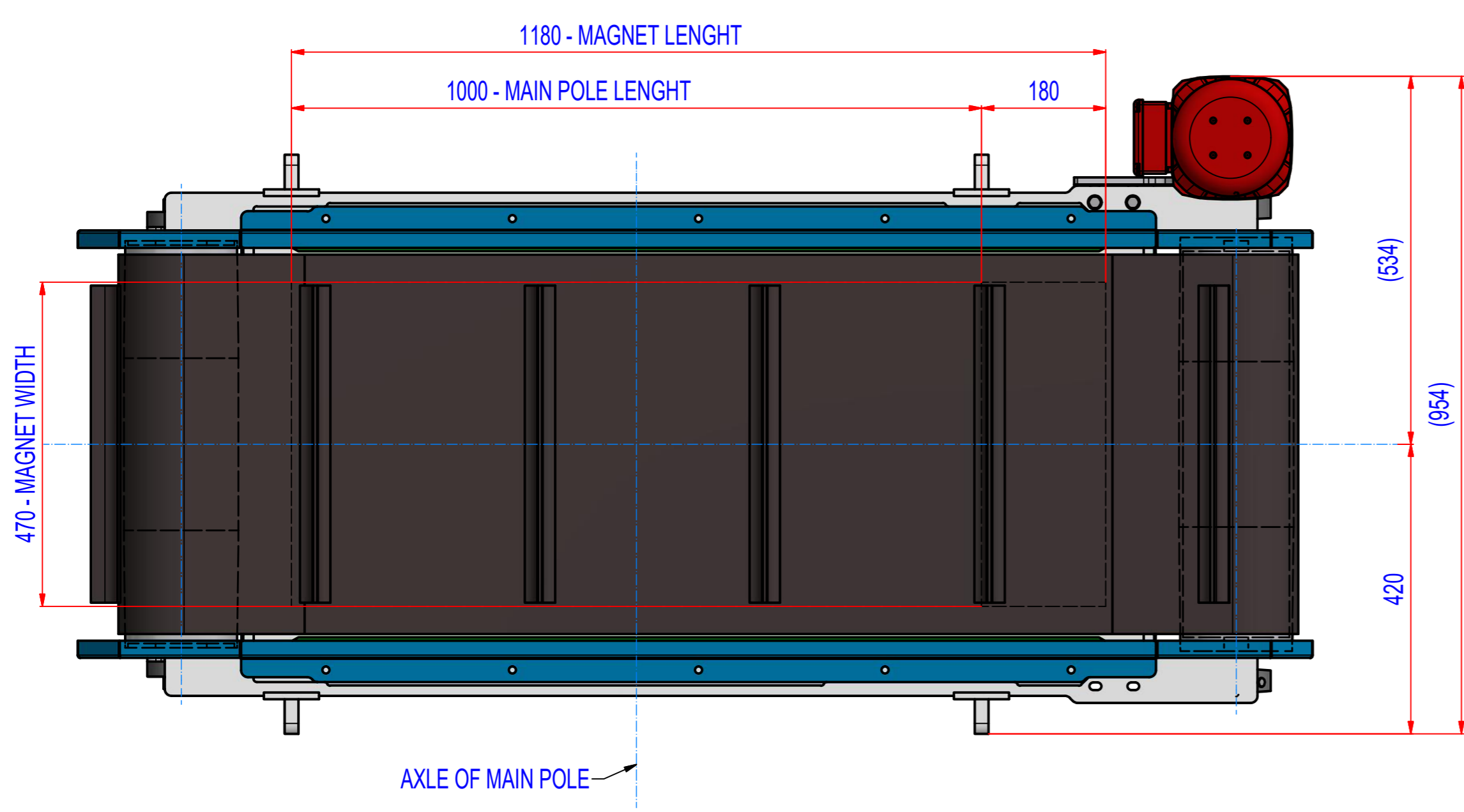
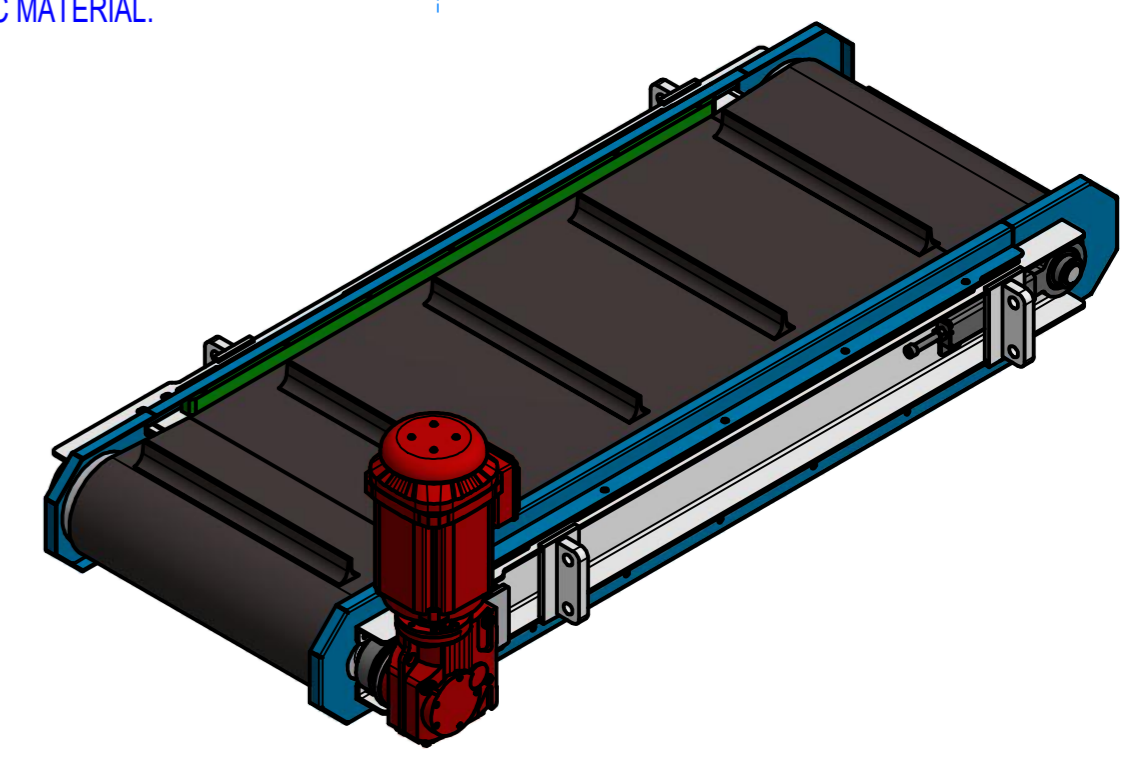

MAGNET:	NdFeB N38
FRAME:	STAINLESS STEEL AISI304
PROTECTION COVERS:	STAINLESS STEEL AISI304
BELT TYPE:	EP250/3 4+2, WIDTH 550, LENGTH 3610, 11 CLEATS T40/10, WIDTH 460
BELT SPEED:	1,5 m/s ASSEMBLING OF ENDLESS BELT IS POSSIBLE FROM THE SIDE
DRIVE MOTOR:	SEW KA37DRN90L4/C, i=7,96 (184 RPM), 230/400V, 1,5kW, IP55 DRIVE MOTOR ON OPOSITION SIDE IS OPTIONAL
DRIVE ROLLER:	DIAMETER 166mm, CARBON STEEL, BEARINGS ASSEMBLY PSHE40
RETURN ROLLER:	DIAMETER 166mm, CARBON STEEL, BEARINGS ASSEMBLY PHUSE35

Sheet: A2	Extra info:	General tolerance: ISO 2768 - cL
Drawn: PH	Weight (kg): 605	Drawn according: ISO268; ISO1101; ISO2553
Date: 12.12.2017		Status:
Predecessor:		Customer reference number:
Quick search: ASPB1000	© All rights reserved. Reproduction is not permitted without written permission of GOUDSMIT Magnetic Systems BV	Product key: ROP-N3-C-100-W-G-L-B-B-NA
Description: Permanent overbelt NdFeB magnet 33/1000		Part number: RONC100330

COLOR USED ON DRAWING MAY BE DIFFERENT IN COMPARISON WITH FINAL EXECUTION
THE INFORMATION CONTAINED IN THIS DOCUMENT MAY BE EDITED OR UPDATED BY WAMAG WITHOUT ANY PRIOR NOTICE
THIS DRAWING AND INFORMATION IS THE PROPERTY OF WAMAG AND MUST NOT BE COPIED, PASSED ON OR RELATED TO A THIRD PARTY WITHOUT WRITTEN PERMISSION.