

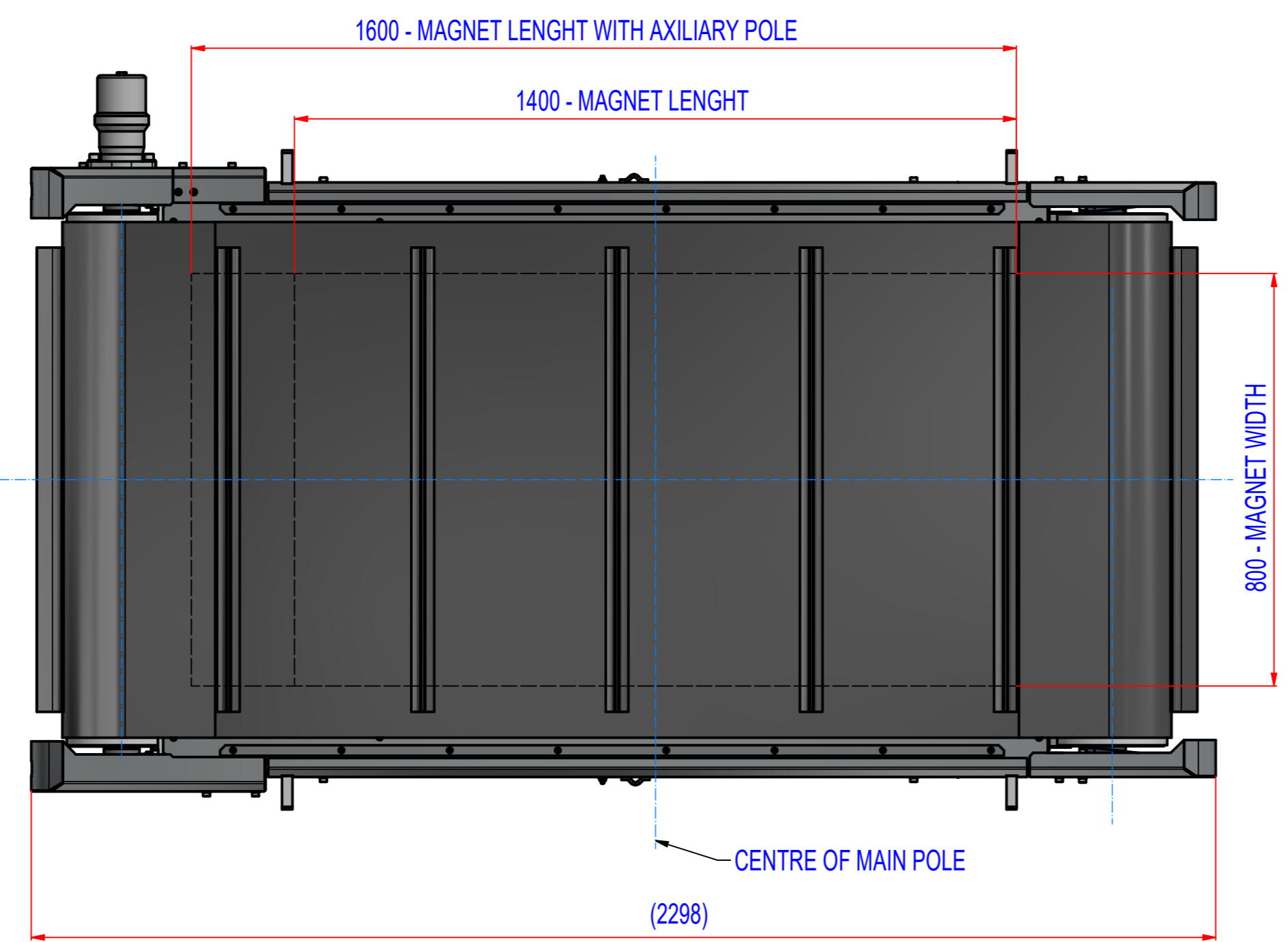

REV	DATE	BY	DESCRIPTION
-	29.04.2022	PH	Source RONC120551

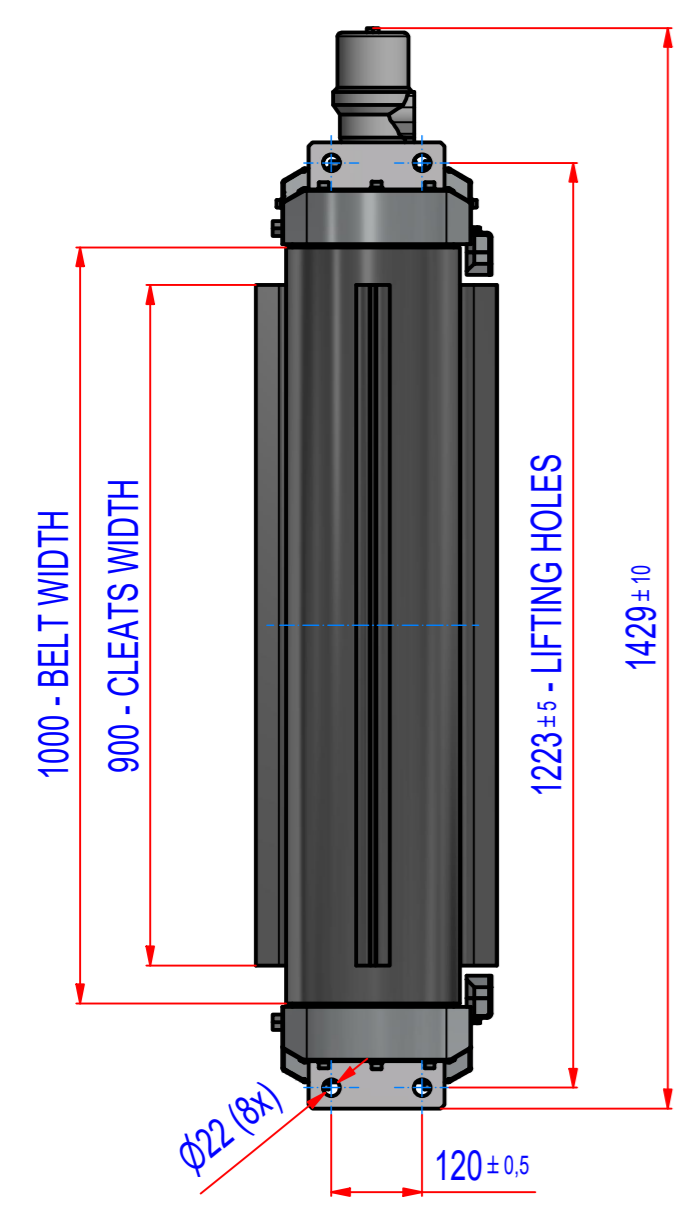
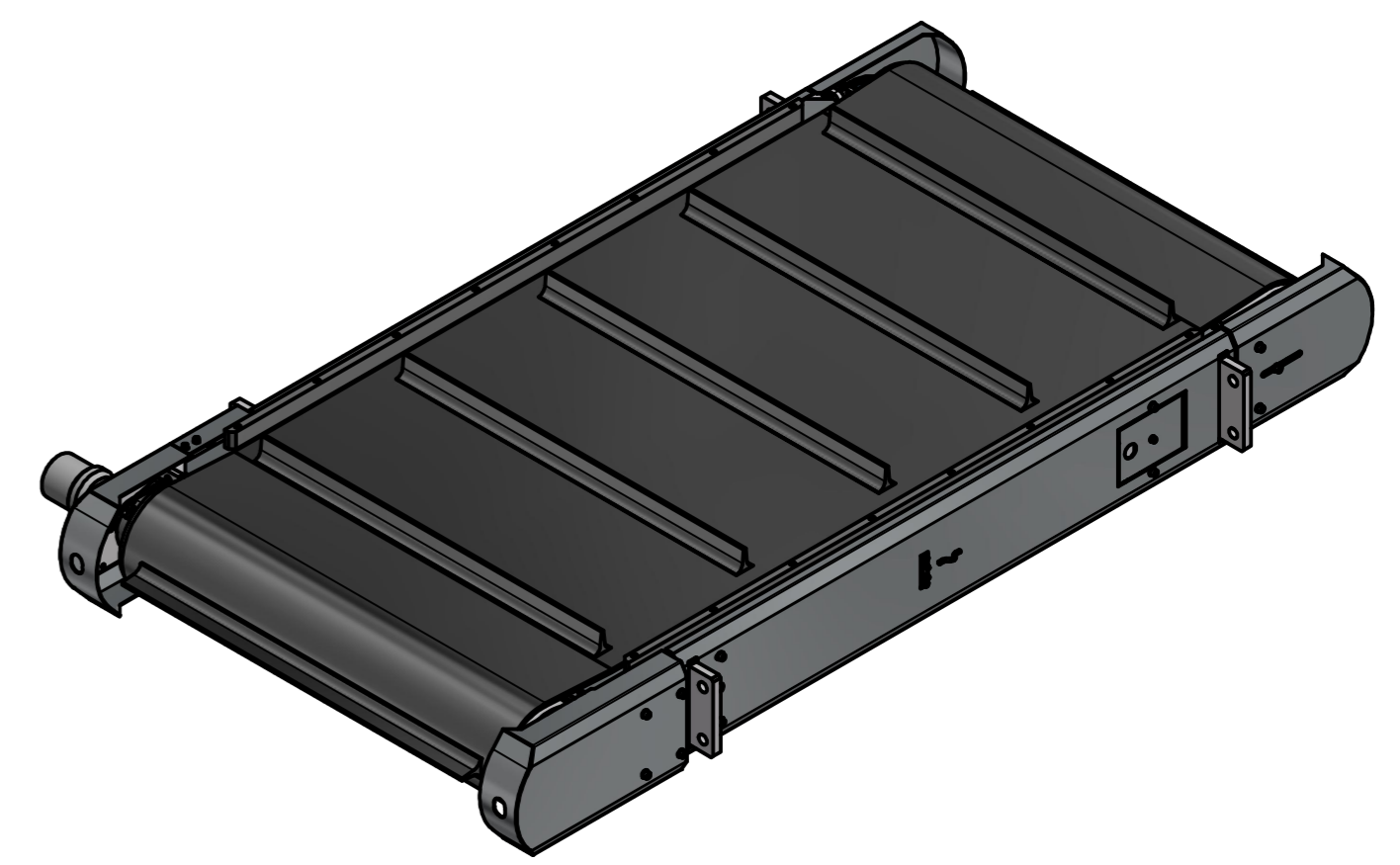
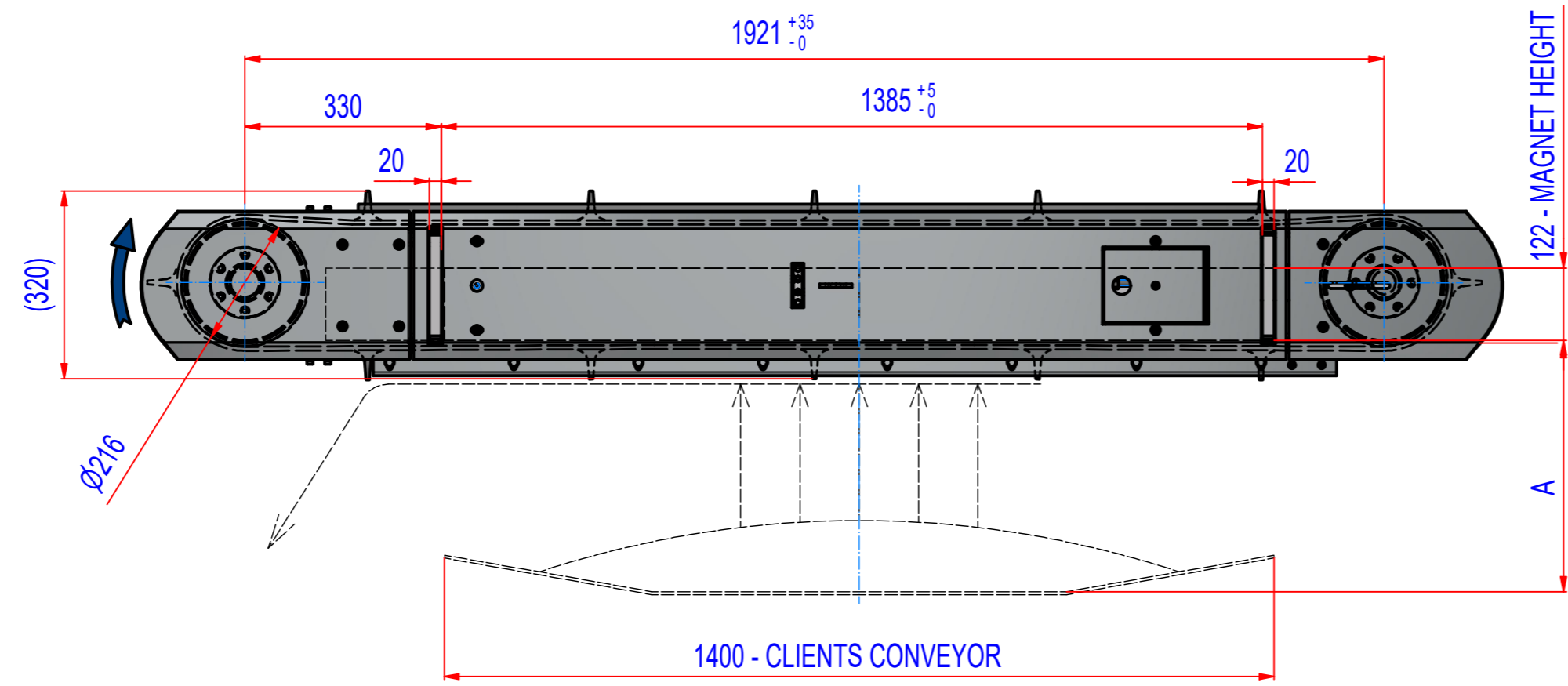

A = 440 mm - max. catch distance for rod Ø15, L=75 mm (VDE)  
A = 375 mm - 400 Gs

MAGNET :	MAGNETS NdFeB, FERRITTE, WATERPROOF
FRAME:	MADE FROM AISI 304
PROTECT PLATES:	AISI 304, 2-3mm
BELT TYPE:	EP250/2 4+2, WIDTH 1000, LENGTH 4540, 12 CLEATS T50/20, WIDTH 900, COMPLETELY HOT VULCANISED
MOTOR:	Hydromotor OMR X 315, 11186652 (or equivalent)
FINISH:	PAINTED / GRIT BLASTED (covering, frame)
ROLLERS:	STEEL, WITH CROWNING, RAL7022 ( UMBRA GREY )
ACCESSORIES:	FRAME SIDE COVERS GREASING FROM LEFT AND RIGHT SIDE

Sheet: A2	Extra info:	General tolerance: ISO 2768 - cL
Drawn: PH	Weight (kg): 1162.3	Drawn according: ISO268; ISO1101; ISO2553
Date: 29.04.2022		Status:
Predecessor:		Customer reference number:
Quick search:	© All rights reserved. Reproduction is not permitted without written permission of GOUDSMIT Magnetic Systems BV	Product key: ROP-N5-C-140-W-H-R-B-B-M-NA
Description: Overband magnet, NdFeB, size.5, W=1400, hydro motor	Part number: RONC140551	Rev: -