

REV	DATE	BY	DESCRIPTION
-	9-4-2019	RO	NEW REVISION VAULT, NOTHING CHANGED, OLD REV WAS B
A	5-5-2020	CR	DIMENSIONS MOTOR CHANGED

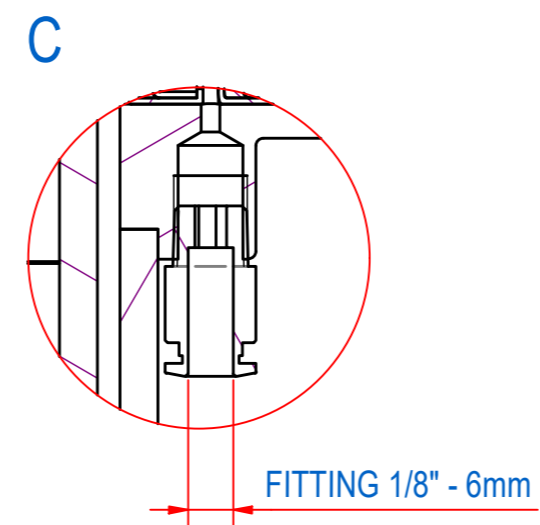
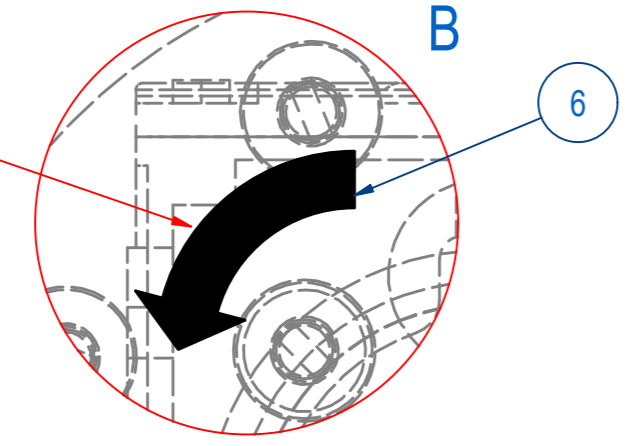
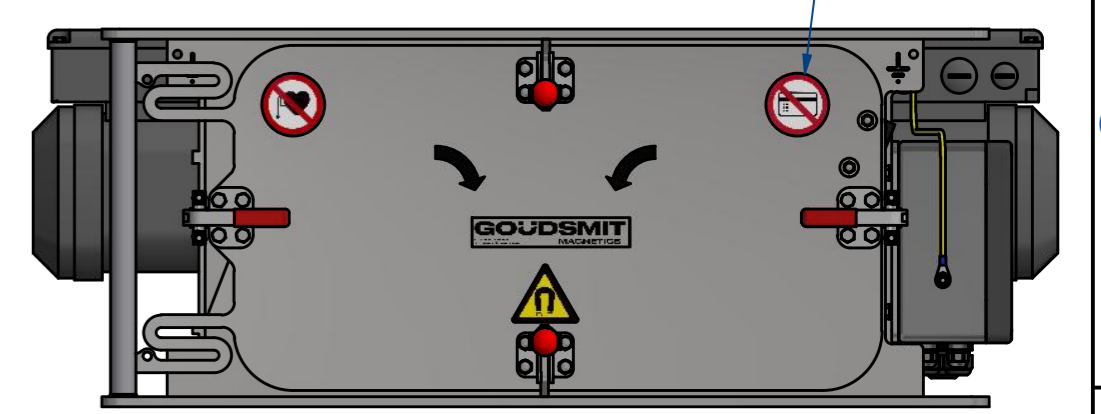
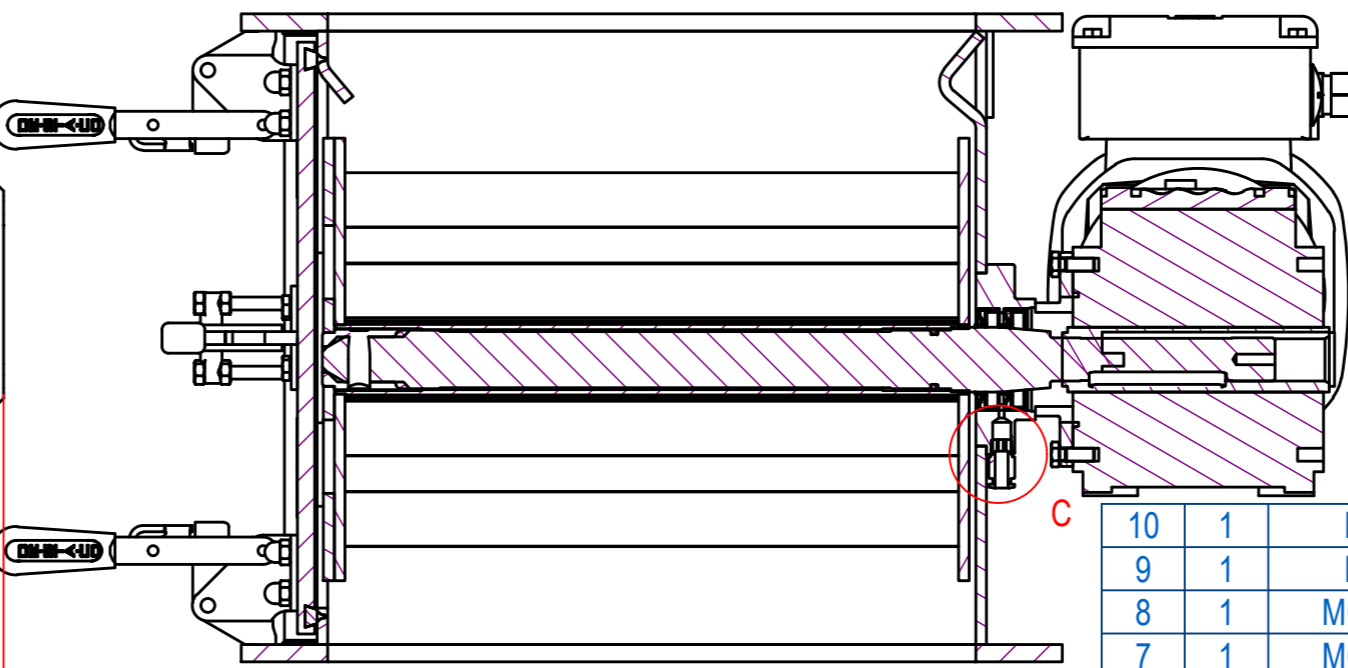
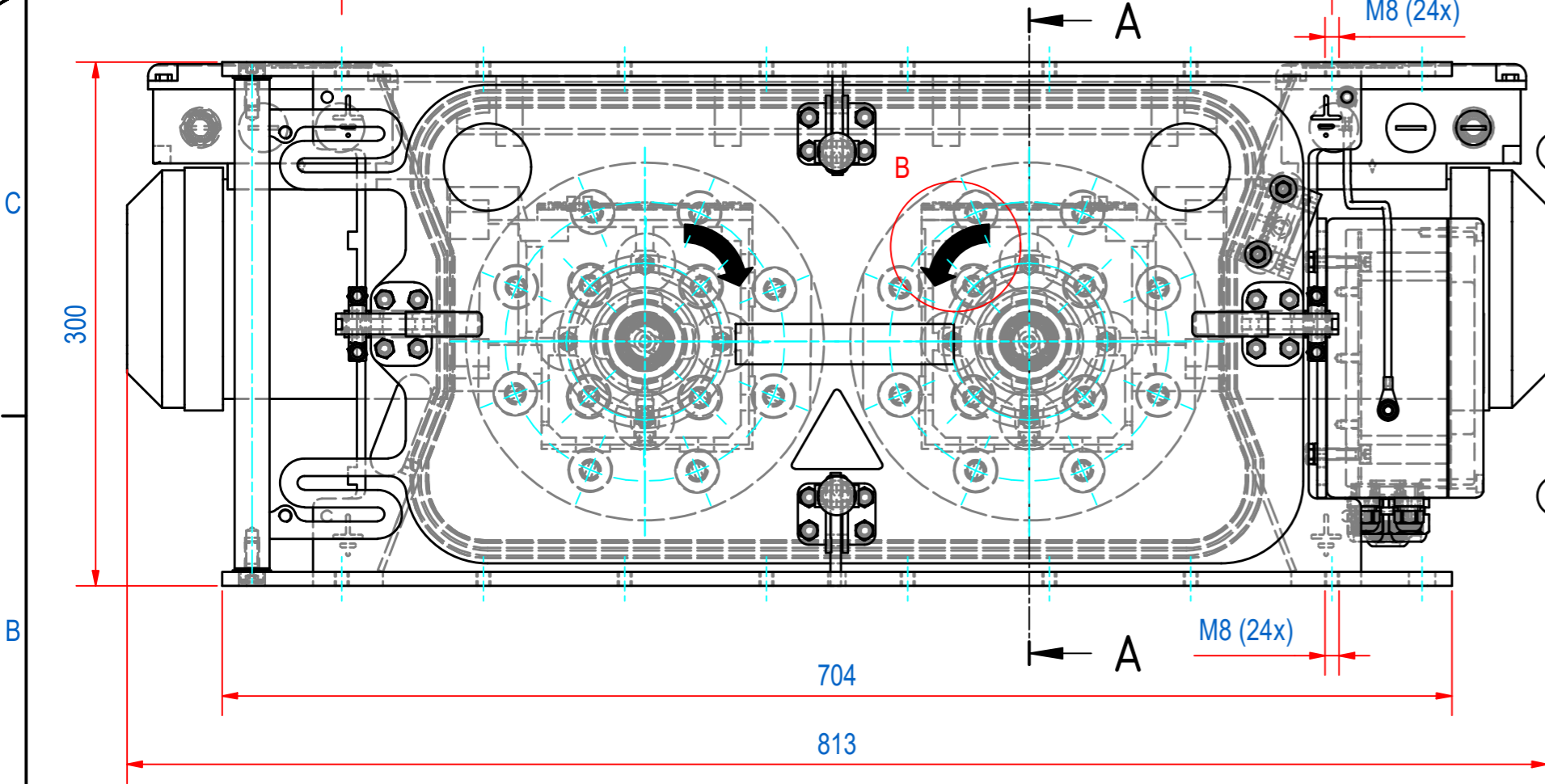
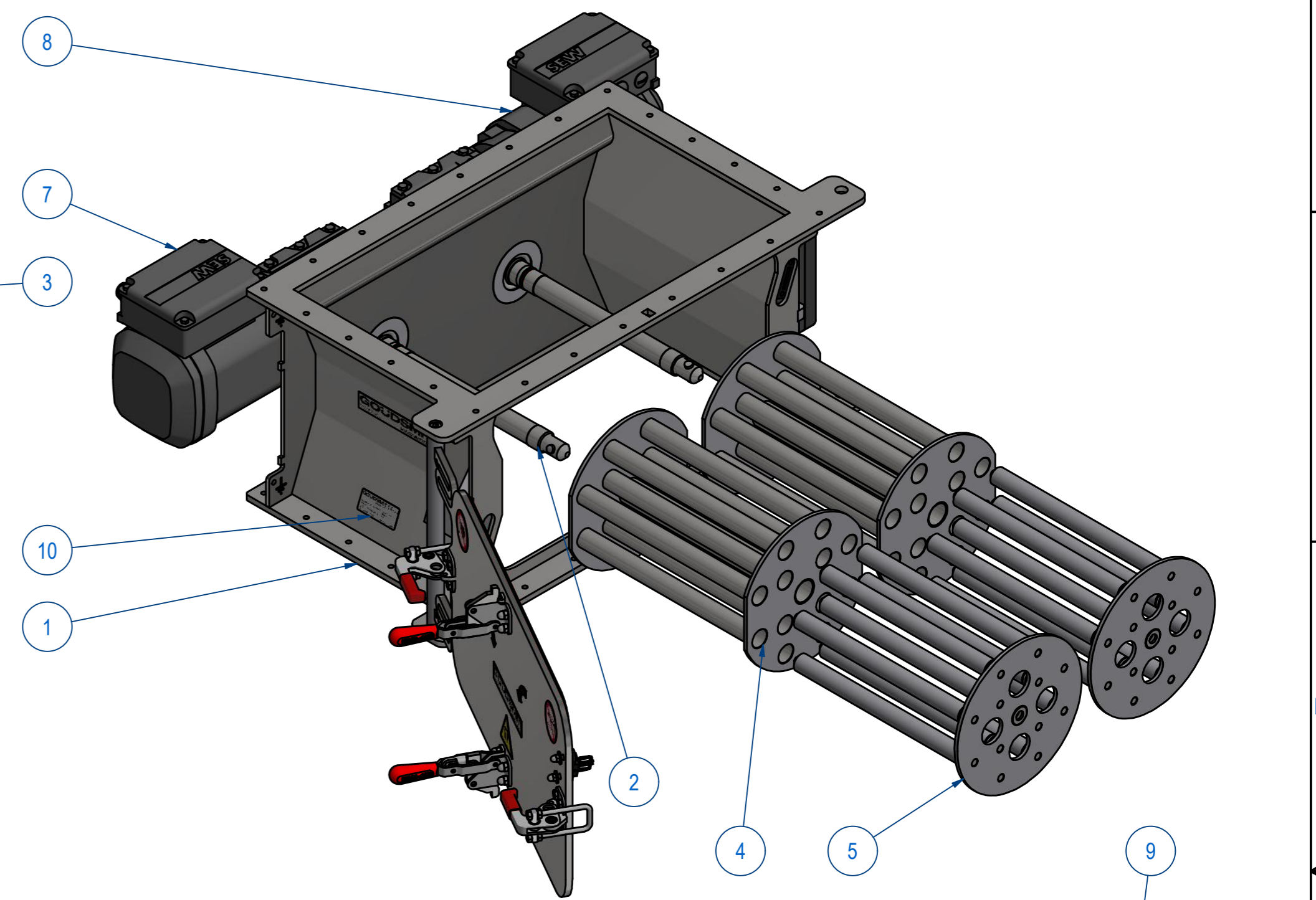
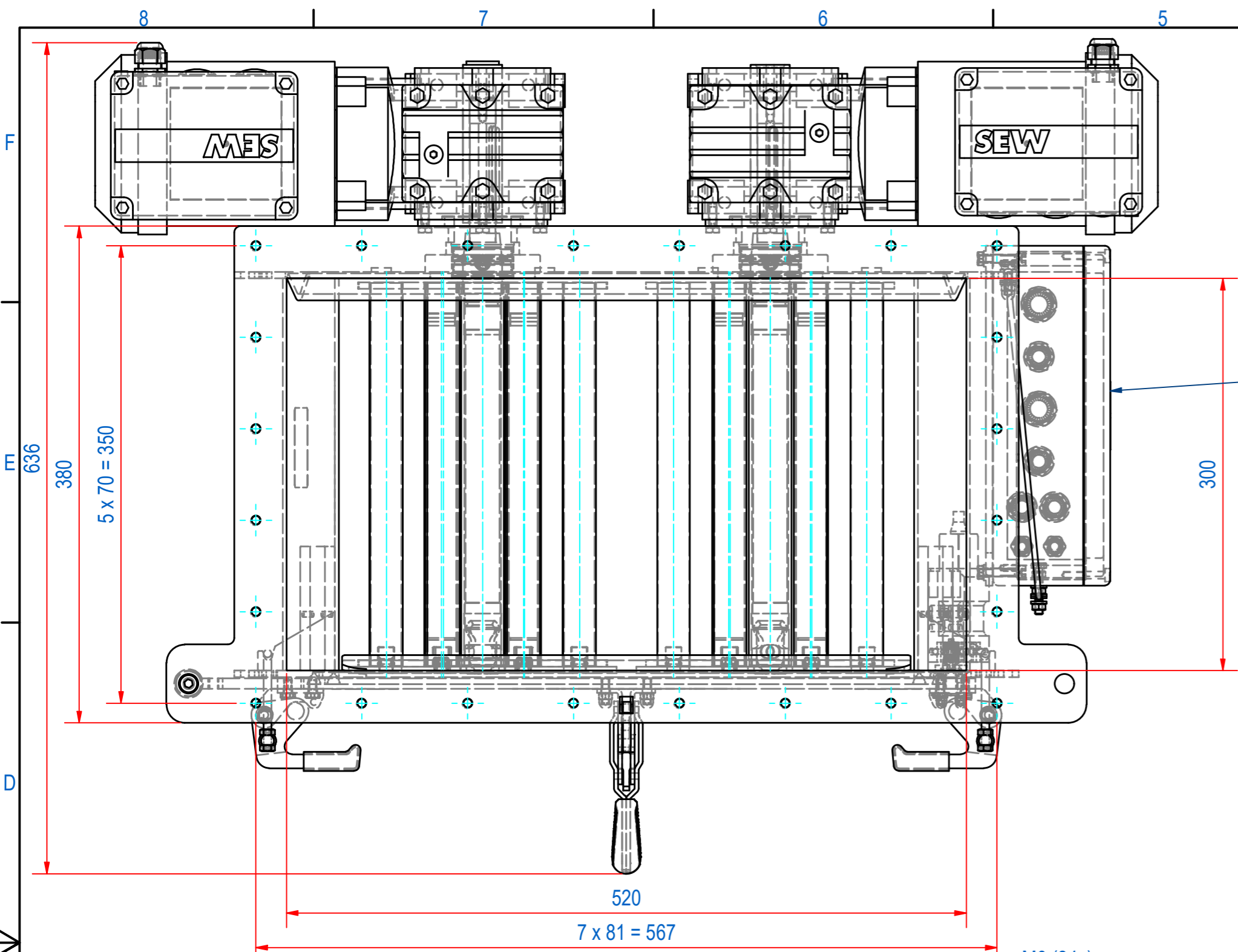

ITEM	QTY	PART NUMBER	DESCRIPTION	Dimensions
10	1	E0090155	TYPE PLATE SECR II 1/2D c T140°C	
9	1	E0090159	STICKERS FOR SCRA/SCRB	
8	1	MO03704202	WA30/II2GD EDRS71M4/2GD/KCC/AL 42RPM	
7	1	MO03704222	WA30/II2GD EDRS71M4/2GD/KCC/AL 42RPM	
6	2	E0060897	TURNING DIRECTION CR5320	
5	2	E0047666	FRONT PLATE WITH 12B NdFeB	
4	2	A240050	EXTRACTOR 12 BARS CR3030	
3	1	A240198	TERMINAL BOX TWIN ROTOR ASSY	
2	2	A240060	SHAFT ASSY CR3030	
1	1	A240187	HOUSING + DOOR CR520x300	

RAW MAT.	Quantity	Material Number	Material Description	Length (mm)	Width (mm)
1	1				

Sheet: A2 Drawn: FS Date: 28-9-2016 Spare part: False Quick search: CR5230	Extra info: Weight (kg): 93 Source: CR5230	General tolerance: ISO 2768 - mK Drawn according: ISO 268; ISO 1101; ISO 2553 Status: Standard Customer reference number: E0107167 Document number: E0107167 Part number: SCRA5230022
---	---	---

© All rights reserved. Reproduction is not permitted without written permission of GOUDSMIT Magnetic Systems BV

GOUDSMIT MAGNETICS

Description: **SECR-B-5230-24E-N-Ex-F1m-B-B**