

REV	DATE	BY	DESCRIPTION
A	14-6-2018	CR	TYPE PLATE AND WARNING STICKERS ADDED
B	8-7-2019	CR	EXTRACTOR CHANGED: LASER WELDING WAS BRAZING
C	30-6-2023	CR	TOLERANCE OF HEIGHT DIMENSION TO 160+/-2mm, SOURCE CODE ADDED, -SR ADDED TO PRODUCT KEY (SILICON RED SEAL)

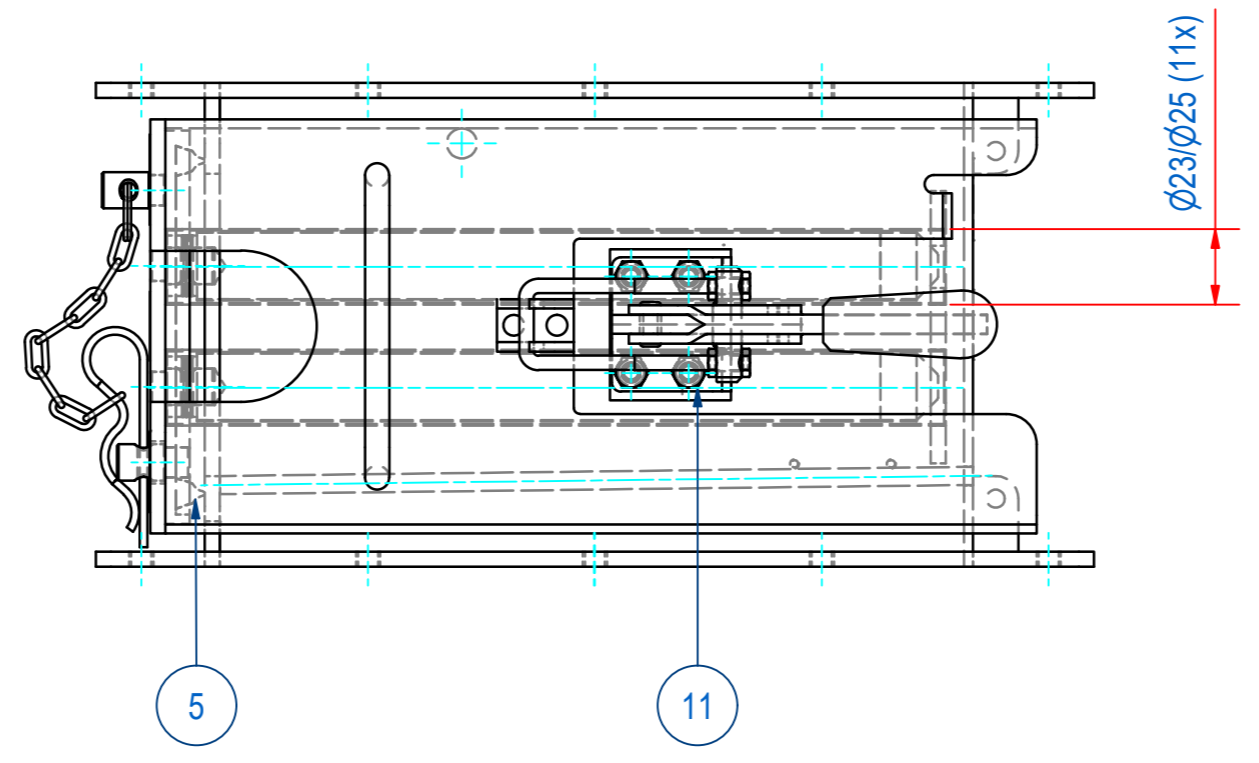
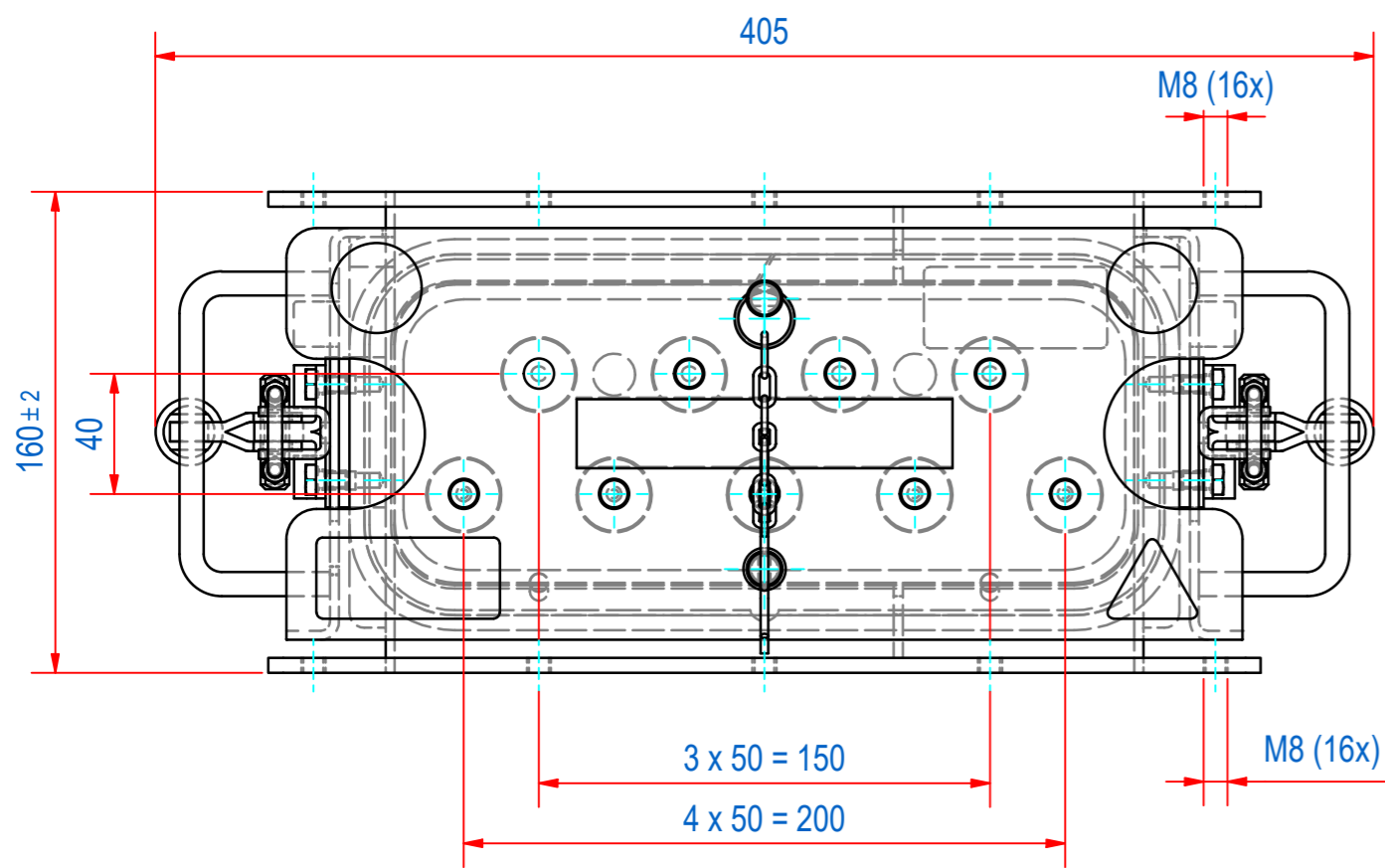
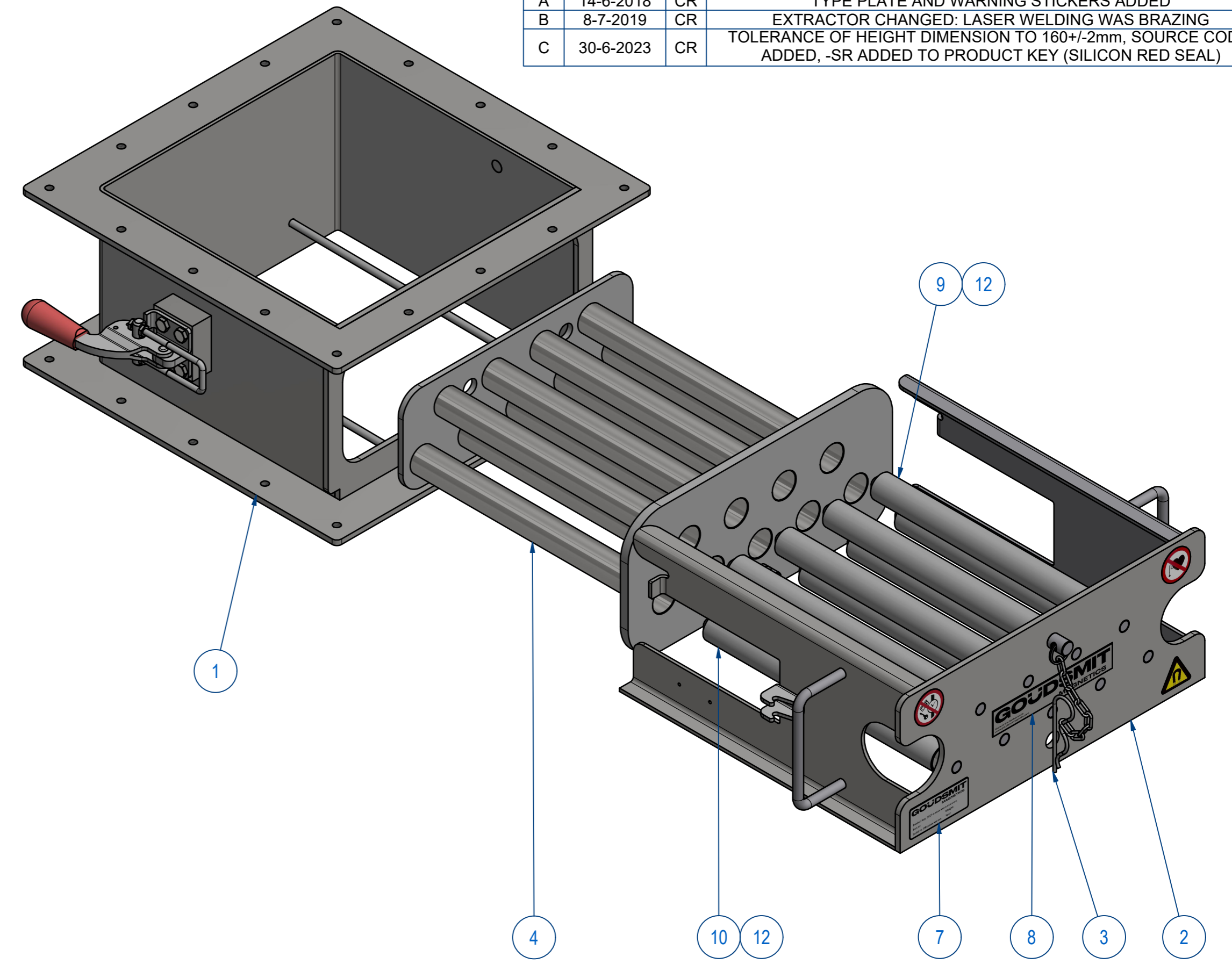
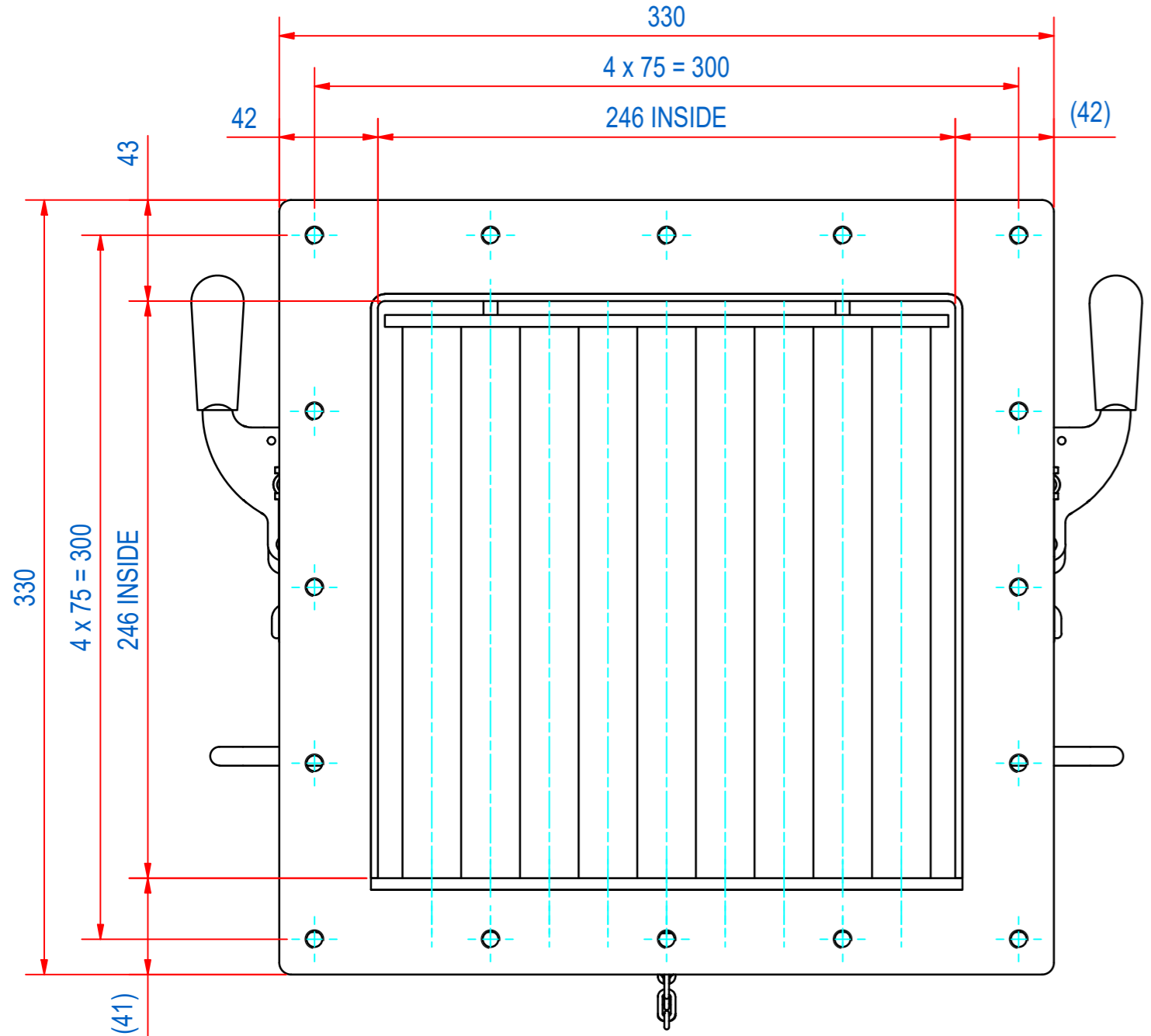

ITEM	QTY	PART NUMBER	DESCRIPTION	Dimensions
12	9	72.9900002	PIN, S SLOTTED 3 x 20 - A2	3 x 20
11	8	50.1306010	BOLT, HEX M6x10-A4	M6 x 10
10	5	SBAME100009-255	BAR-N-23-255-25-CPC-SH-B	
9	4	SBAME100000-255	BAR-N-23-255-25-CPC-SW-B	
8	1	E0093454	STICKERS FOR SECF250-300-350	
7	2	E0086350	TYPE PLATE SECF	
5	1	E0004248	SECF-S-2525 SEAL SILI RED EC1935	
4	1	M79834	SECF-S-2525 EXTRACTOR 9B	
3	1	M15489	SECF-S-LOCK WITH CHAIN "SAFE"	
2	1	A110166	SECF-2525 FRONT INSERT 9B	
1	1	A110165	SECF-WELD ASSY HOUSE CF2525	

RAW MAT.	Quantity	Material Number	Material Description	Length (mm)	Width (mm)
	1				

Sheet: A2	Extra info:	General tolerance: ISO 2768 - mK
Drawn: CR	Weight (kg): 22	Drawn according: ISO268; ISO1101; ISO2553
Date: 8-7-2019		Status: Standard
Spare part: False	Source: MC-C	Customer reference number:
Quick search: CF2525		
Description: SECF-B-2525-09E-N-F5m-W-B-B-SR	Document number: SECF250538	Doc.Rev: C
	Part number: SECF250538	Rev: C