

REV	DATE	BY	DESCRIPTION
A	8-9-2014	BS	HOUSE CHANGED
B	8-7-2019	CR	TYPE PLATE AND WARNING STICKERS ADDED EXTRACTOR CHANGED: LASER WELDING WAS BRAZING
C	30-6-2023	CR	TOLERANCE OF HEIGHT DIMENSION TO 160+/-2mm, SOURCE CODE ADDED, -SR ADDED TO PRODUCT KEY (SILICON RED SEAL)

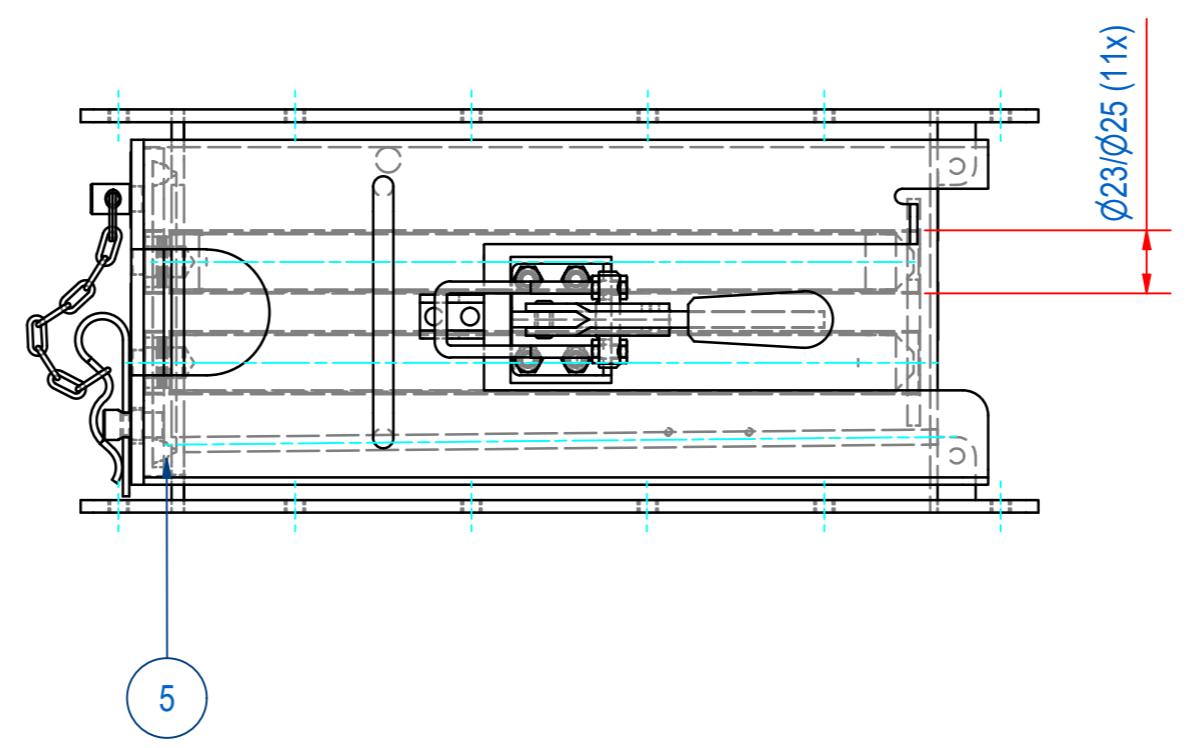

ITEM	QTY	PART NUMBER	DESCRIPTION	Dimensions
11	11	72.9900002	PIN, S SLOTTED 3 x 20 - A2	3 x 20
10	8	50.1306010	BOLT, HEX M6x10-A4	M6 x 10
9	5	SBAME100009-305	BAR-N-23-305-25-CPC-NW-B	
8	6	SBAME100000-305	BAR-N-23-305-25-CPC-NH-B	
7	1	E0093454	STICKERS FOR SECF250-300-350	
6	2	E0086350	TYPE PLATE SECF	
5	1	E0005412	SECF-S-300-SEAL SILI RED EC1935	
4	1	M15771	SECF-3030-FRONT INSERT 11B	
3	1	M15489	SECF-S-LOCK WITH CHAIN "SAFE"	
2	1	A250375	SECF-S-3030 EXTRACTOR 11B	
1	1	A250192	SECF-WELD ASSY HOUSE CF3030	

ITEM	QTY	PART NUMBER	DESCRIPTION	Dimensions
RAW MAT.	1			
Quantity		Material Number	Material Description	Length (mm) Width (mm)
Sheet:	A2	Extra info:	General tolerance:	ISO 2768 - mK
Drawn:	CR	Weight (kg):	28	Drawn according:
Date:	8-7-2019			ISO268; ISO1101; ISO2553
Spare part:	False	Source:	MC-C	Status:
Quick search:	CF3030			Standard
Description:	SECF-B-3030-11E-N-F5m-W-B-B-SR			Customer reference number:
				Document number:
				SECF300538
				Doc.Rev:
				C
				Part number:
				SECF300538
				Rev:
				C

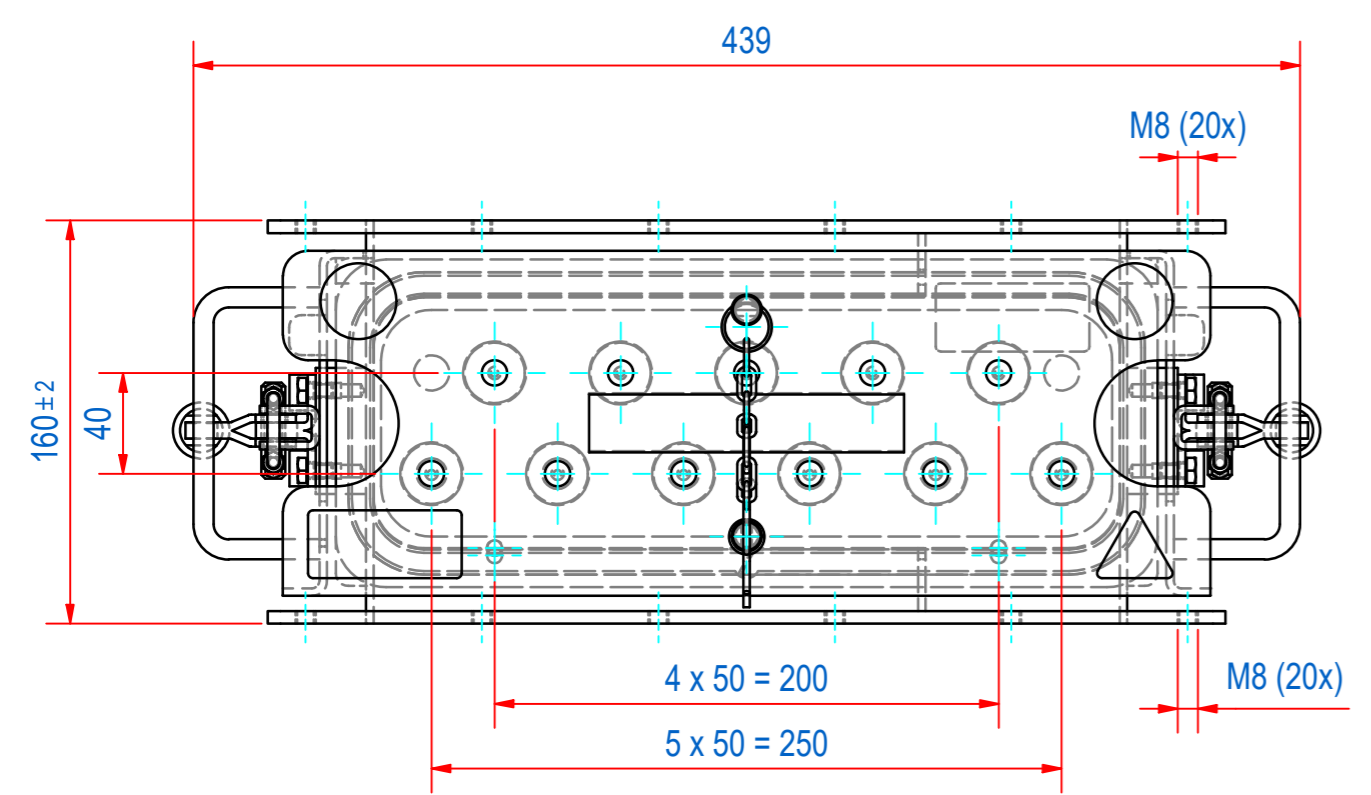
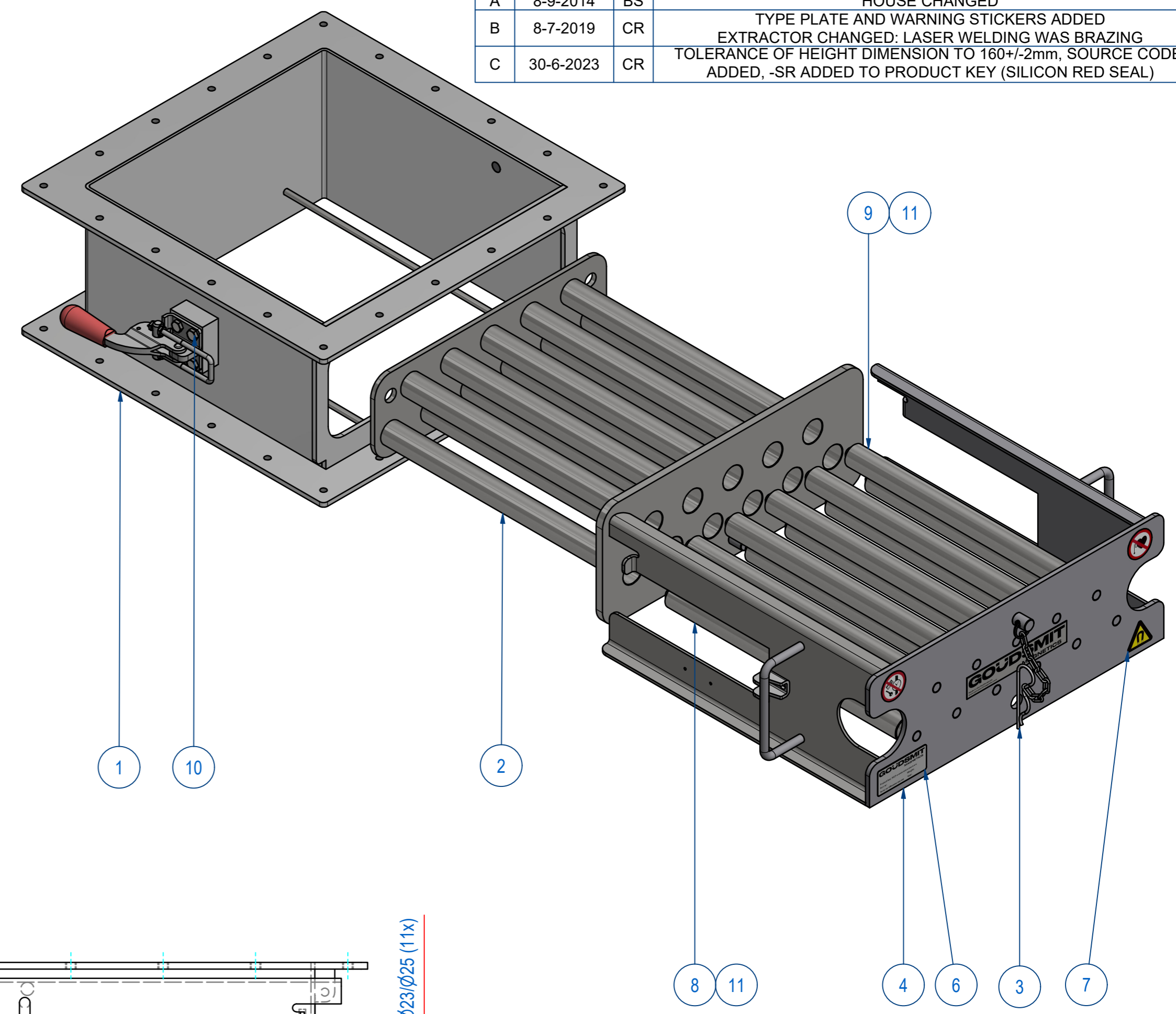
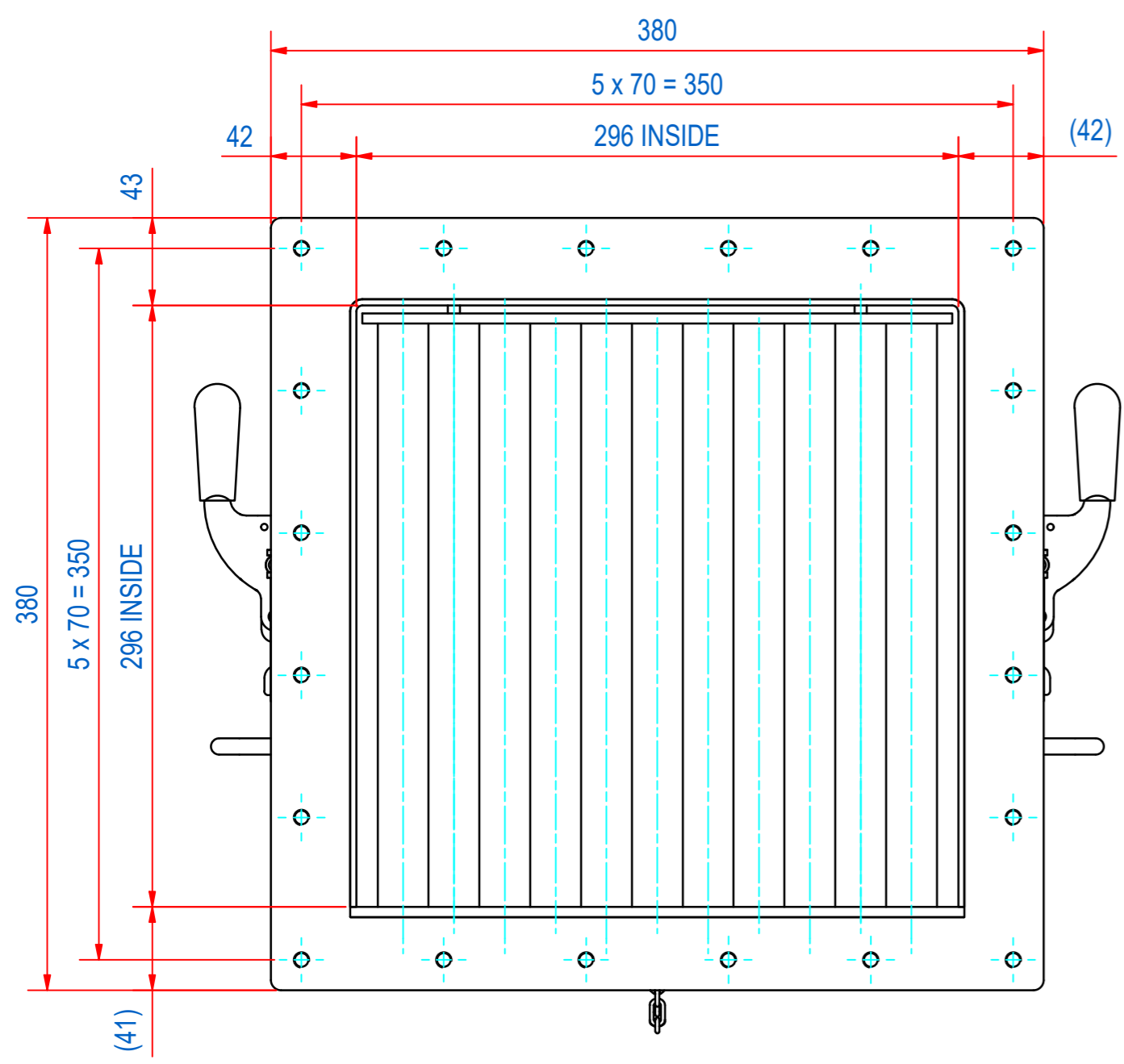

© All rights reserved. Reproduction is not permitted without written permission of GOUDSMIT Magnetic Systems BV