

REV	DATE	BY	DESCRIPTION
-	30-5-2013	CR	NEW REVISION VAULT, NOTHING CHANGED, OLD REV WAS E
A	5-2-2019	CR	TYPE PLATE AND WARNING STICKERS ADDED
B	18-7-2023	CR	GASKET (E0005668) DELETED

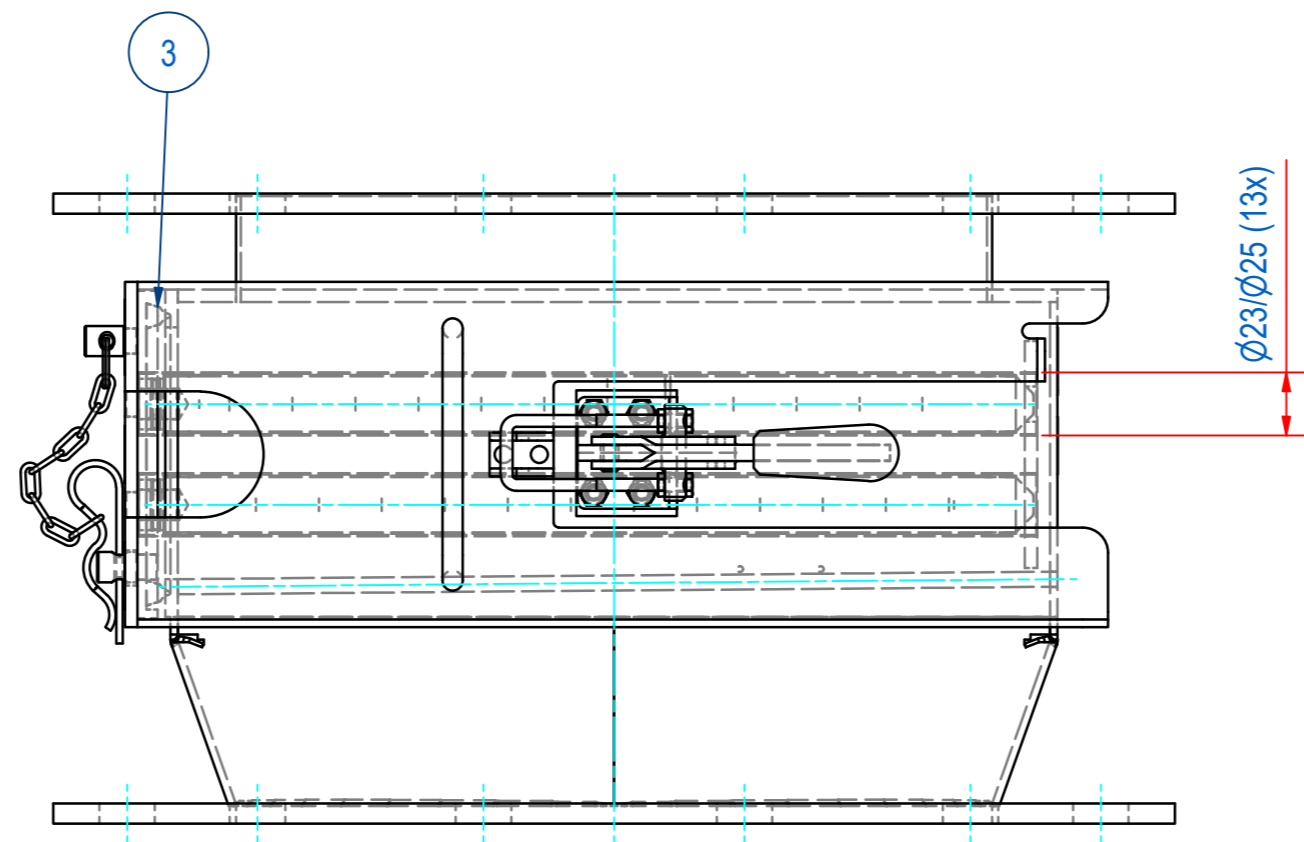
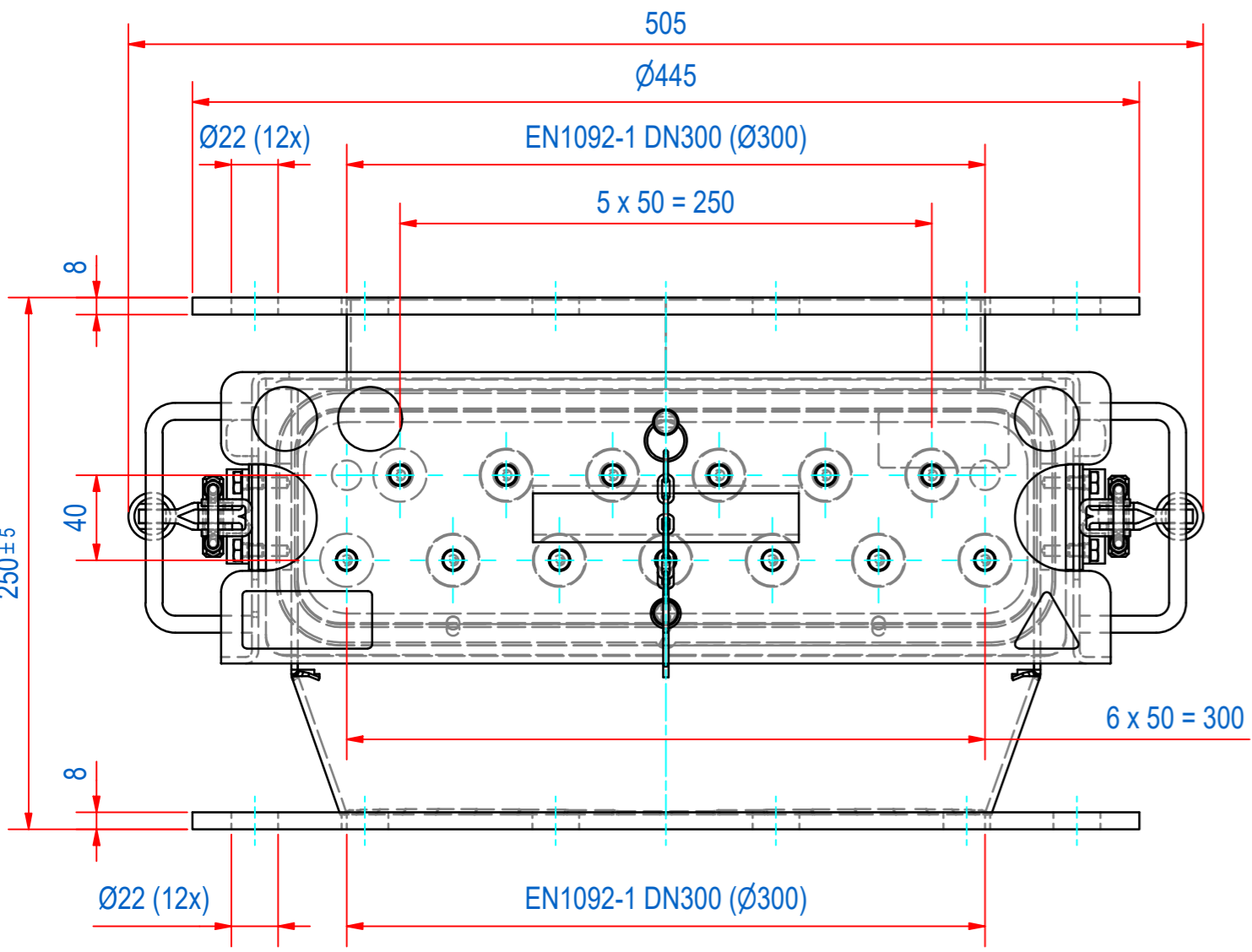
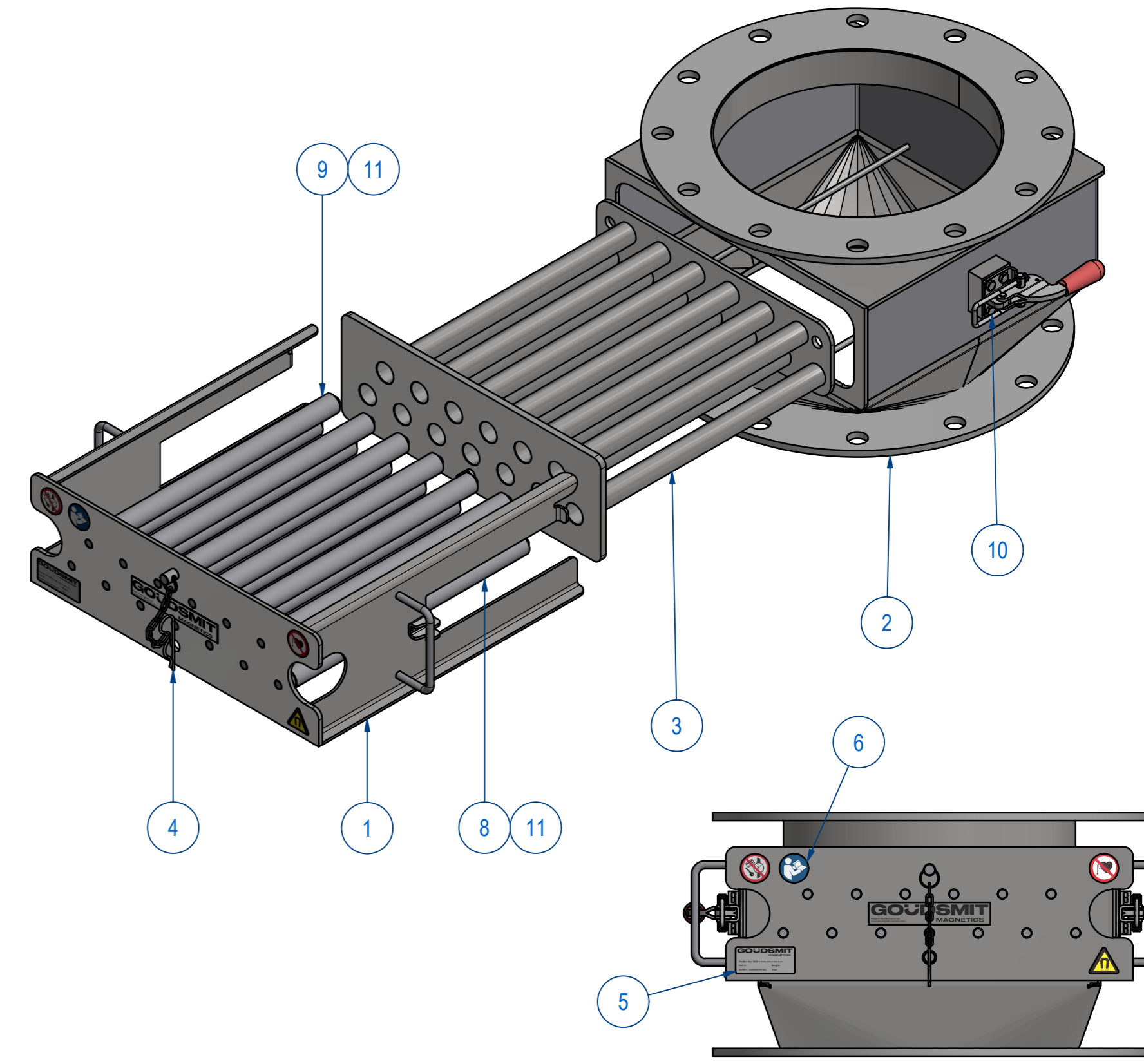
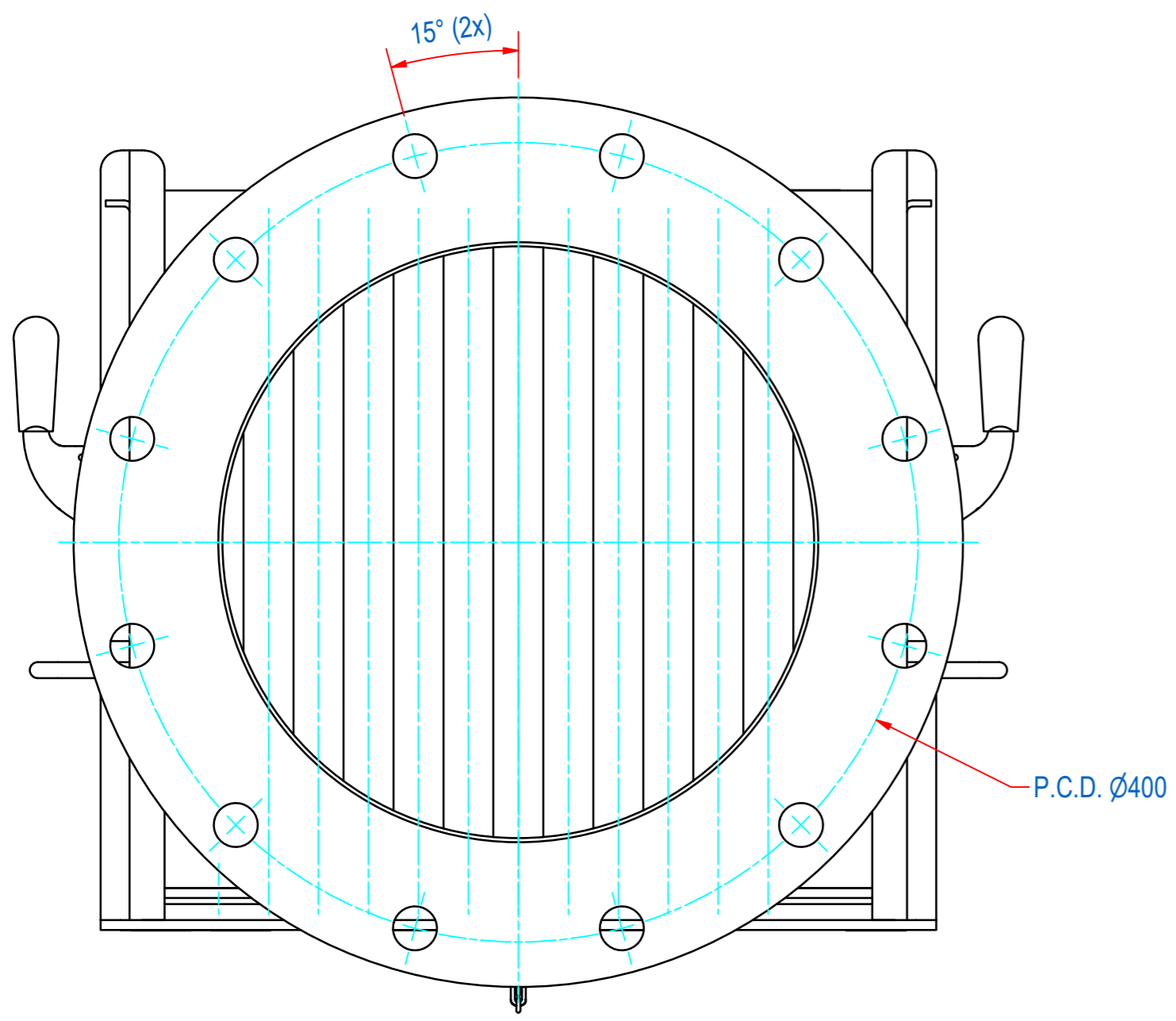

ITEM	QTY	PART NUMBER	DESCRIPTION	Dimensions
11	13	72.9900002	PIN, S SLOTTED 3 x 20 - A2	3 x 20
10	8	50.1306010	BOLT, HEX M6x10-A4	M6 x 10
9	6	SBAME100009-355	BAR-N-23-355-25-CPC-NW-B	
8	7	SBAME100000-355	BAR-N-23-355-25-CPC-NH-B	
7	1	E0005666	SECF-S-GASKET CF300 SILICONE EC1935	
6	1	E0093454	SECF-000 STICKERS	
5	2	E0086350	SECF-000-TYPE PLATE	
4	1	M15489	SECF-S-LOCK WITH CHAIN "SAFE"	
3	1	A250432	SECF-S-EXTRACTOR 6+7 LASER WELD CF300	
2	1	M15917	SECF-WELD ASSY HOUSE CF300	
1	1	M15414	SECF-3535 FRONT INSERT 13B	

RAW MAT.	Quantity	Material Number	Material Description	Length (mm)	Width (mm)
⊕	1				

Sheet: A2	Extra info:	General tolerance: ISO 2768 - mK
Drawn: CR	Weight (kg): 44	Drawn according: ISO268; ISO1101; ISO2553
Date: 12-7-2019		Status: Standard
Spare part: False	Source: MC-C	Customer reference number:
Quick search: CF300		
Description: SECF-B-D300-13E-N-F1E-W-B-B-SR	Document number: SECF300638	Doc.Rev: B
	Part number: SECF300638	Rev: B