

REV	DATE	BY	DESCRIPTION
A	19-2-2019	CR	TYPE PLATE AND WARNING STICKERS ADDED
B	8-7-2019	CR	EXTRACTOR CHANGED: LASER WELDING WAS BRAZING
C	30-6-2023	CR	TOLERANCE OF HEIGHT DIMENSION TO 160+/-2mm, SOURCE CODE ADDED, -SR ADDED TO PRODUCT KEY (SILICON RED SEAL)

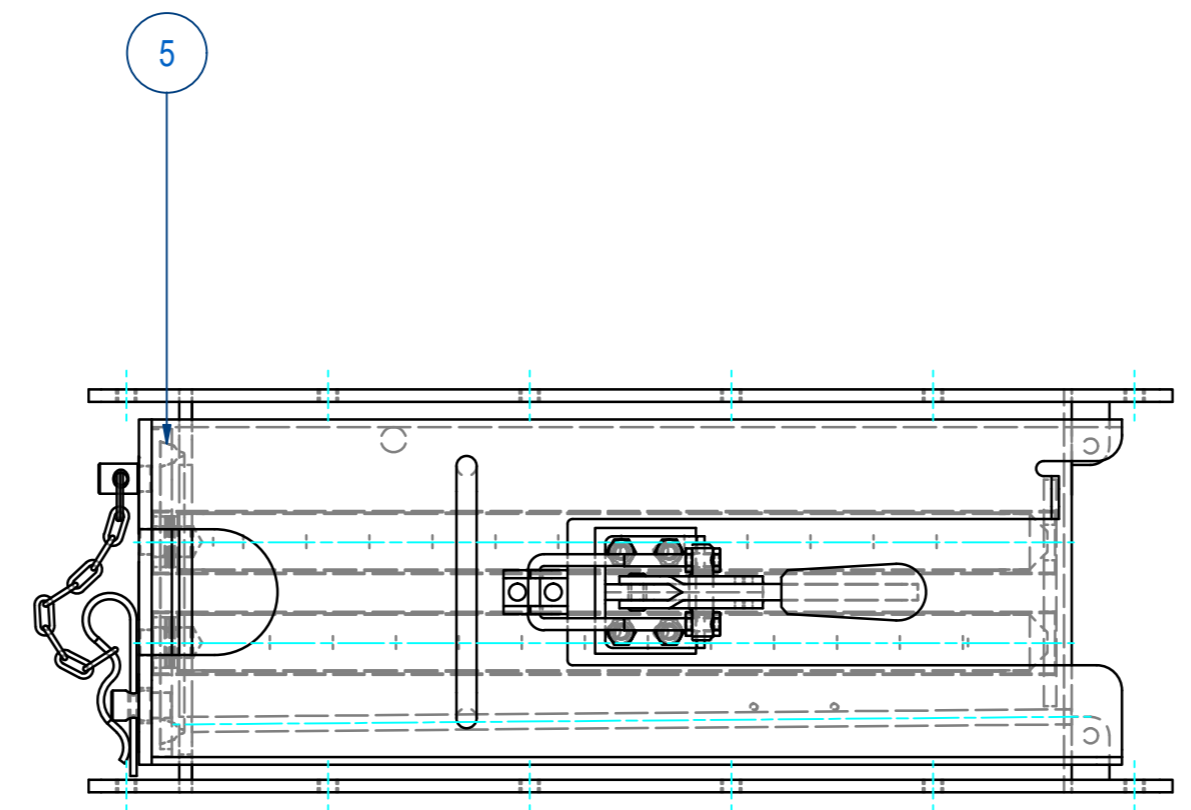
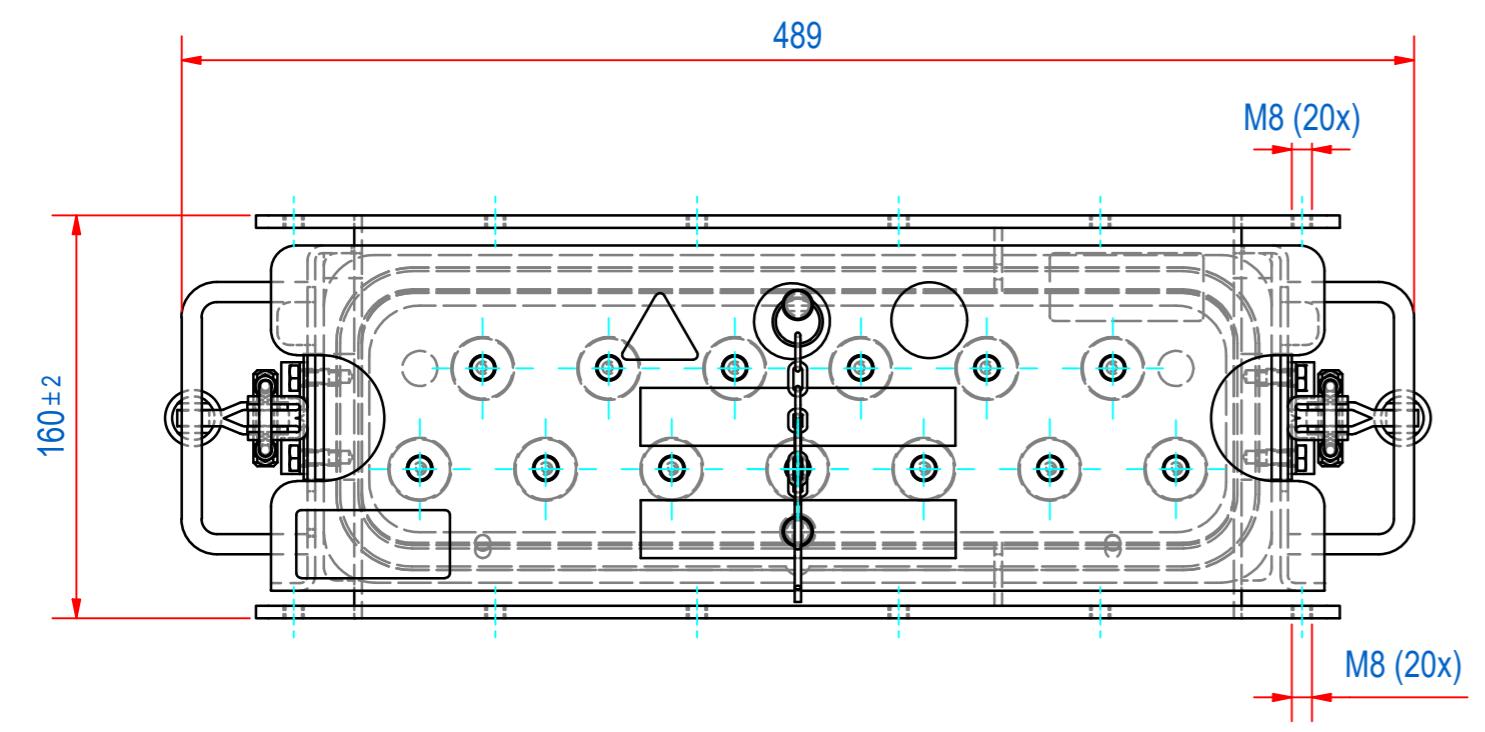
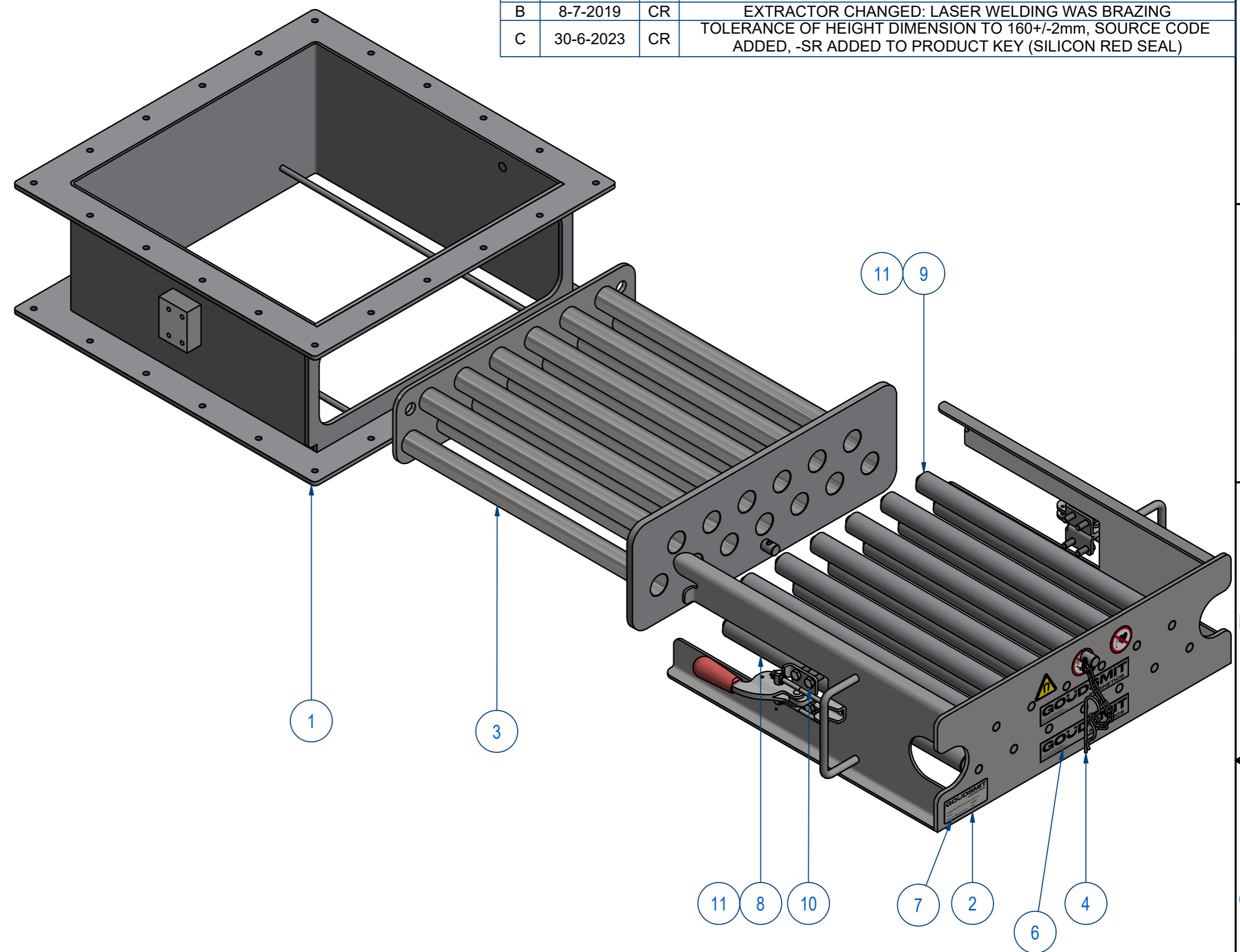
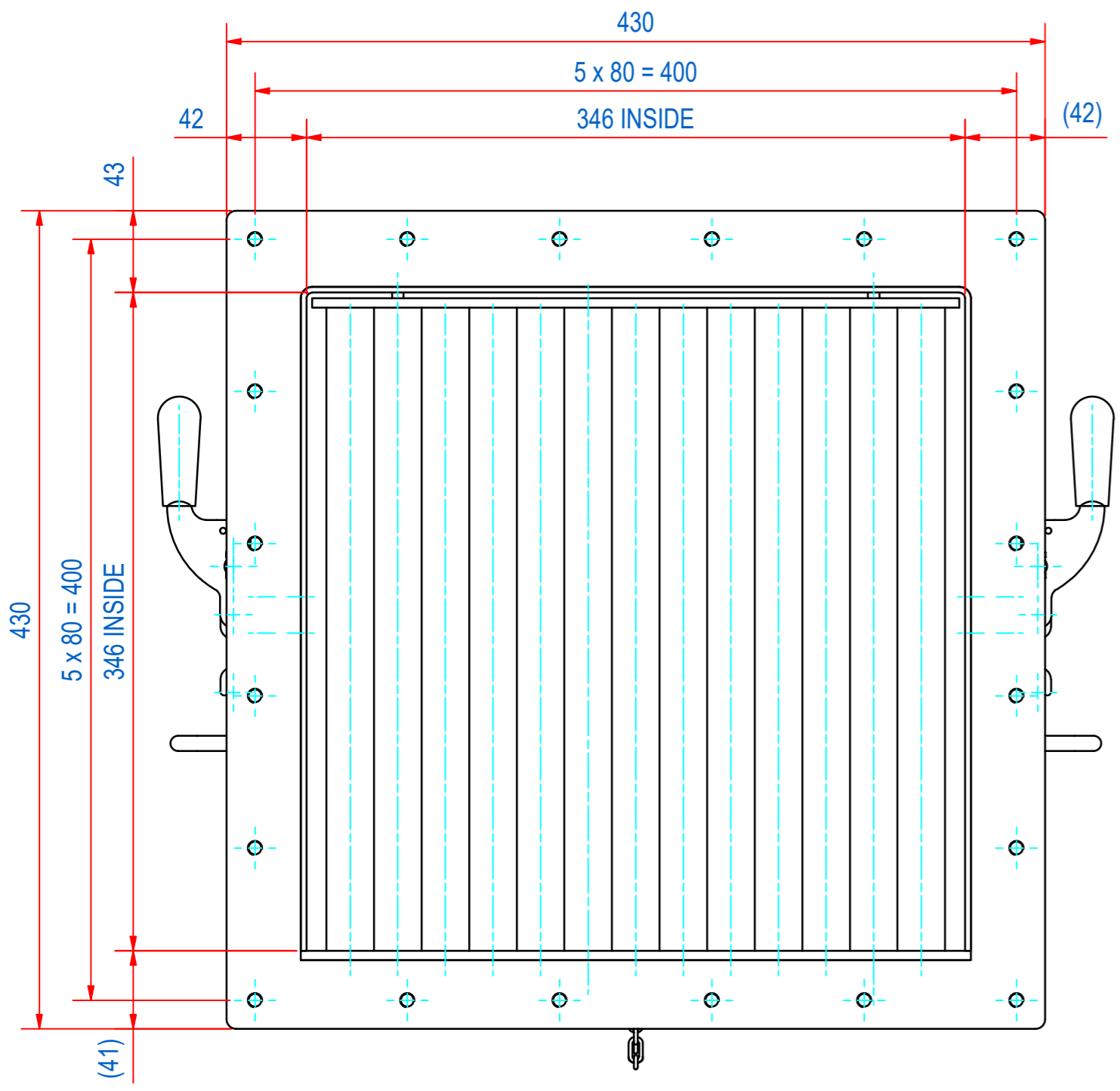

ITEM	QTY	PART NUMBER	DESCRIPTION	Dimensions
11	13	72.9900002	PIN, S SLOTTED 3 x 20 - A2	3 x 20
10	8	50.1306016	BOLT, HEX M6x16-A4	M6 x 16
9	6	SBAME100009-355	BAR-N-23-355-25-CPC-NW-B	
8	7	SBAME100000-355	BAR-N-23-355-25-CPC-NH-B	
7	2	E0086350	TYPE PLATE SECF	
6	1	E0093454	STICKERS FOR SECF250-300-350	
5	1	E0011097	GASKET CF350 SILICONE EC1935	
4	1	M15489	SECF-S-LOCK WITH CHAIN "SAFE"	
3	1	E0011089	SECF-S-3535 EXTRACTOR 13B	
2	1	M15414	SECF-3535 FRONT INSERT 13B	
1	1	E0011102	SECF-WELD ASSY HOUSE CF3535	

RAW MAT.	Quantity	Material Number	Material Description	Length (mm)	Width (mm)
1	1				

Sheet: A2	Extra info:	General tolerance: ISO 2768 - mK
Drawn: CR	Weight (kg): 35	Drawn according: ISO268; ISO1101; ISO2553
Date: 8-7-2019		Status: Standard
Spare part: False	Source: MC-C	Customer reference number:
Quick search: CF3535		
Description: SECF-B-3535-13E-N-F5m-W-B-B-SR	Document number: SECF350538	Doc.Rev: C
	Part number: SECF350538	Rev: C

© All rights reserved. Reproduction is not permitted without written permission of GOUDSMIT Magnetic Systems BV