

REV	DATE	BY	DESCRIPTION
-	26-11-2013	AvD	NEW REVISION VAULT, NOTHING CHANGED, OLD REV WAS A
A	21-8-2018	CR	TYPE PLATE AND WARNING STICKERS ADDED
B	30-6-2023	CR	TOLERANCE OF HEIGHT DIMENSION TO 160+/-2mm, SOURCE CODE ADDED, PRODUCT KEY; -SR ADDED

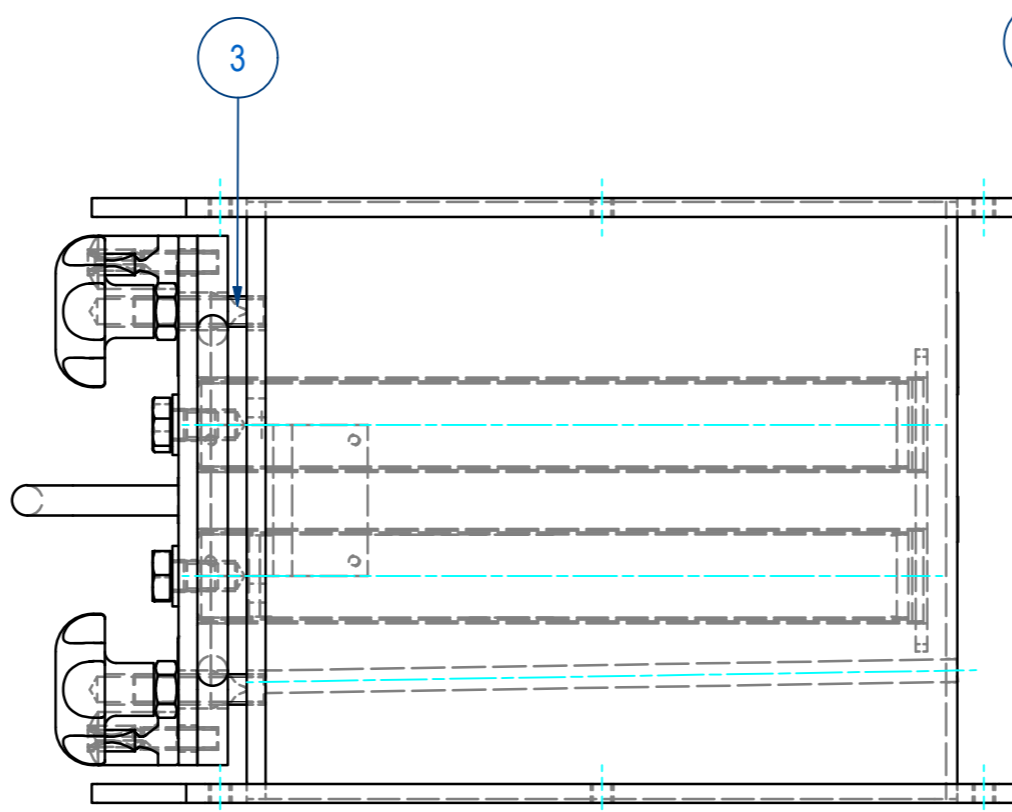

MOUNTING BRACKET FOR DOOR SENSOR

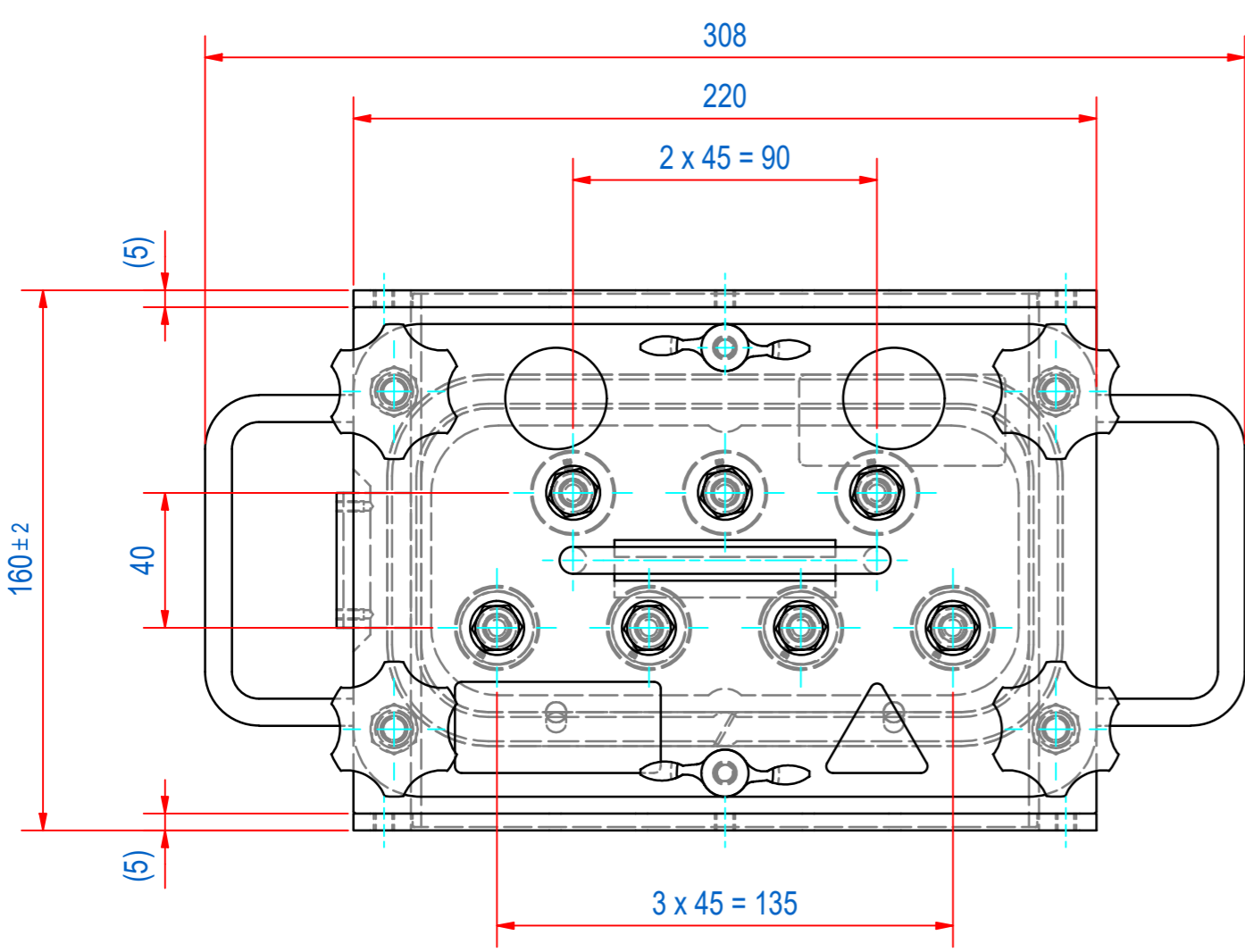
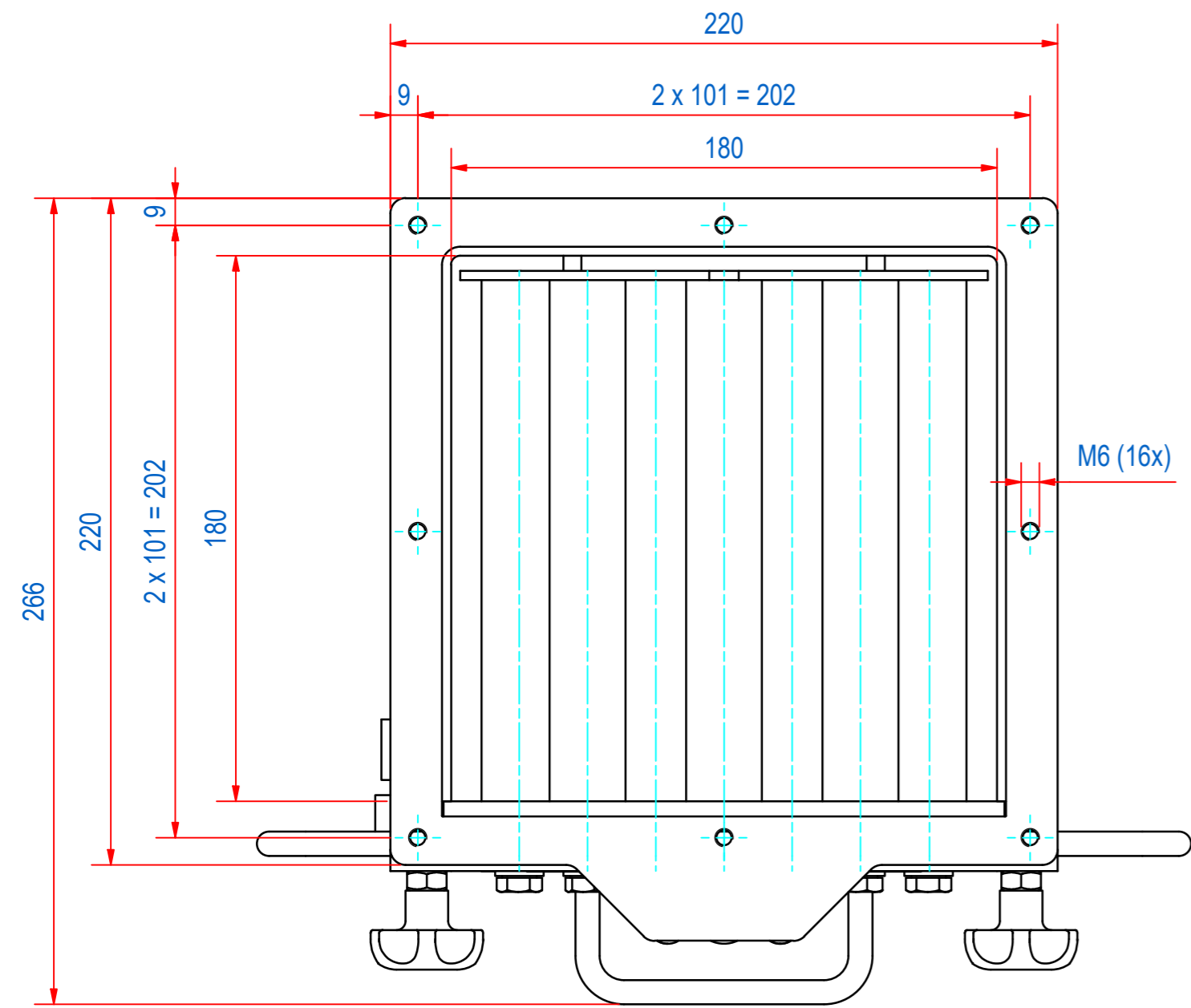
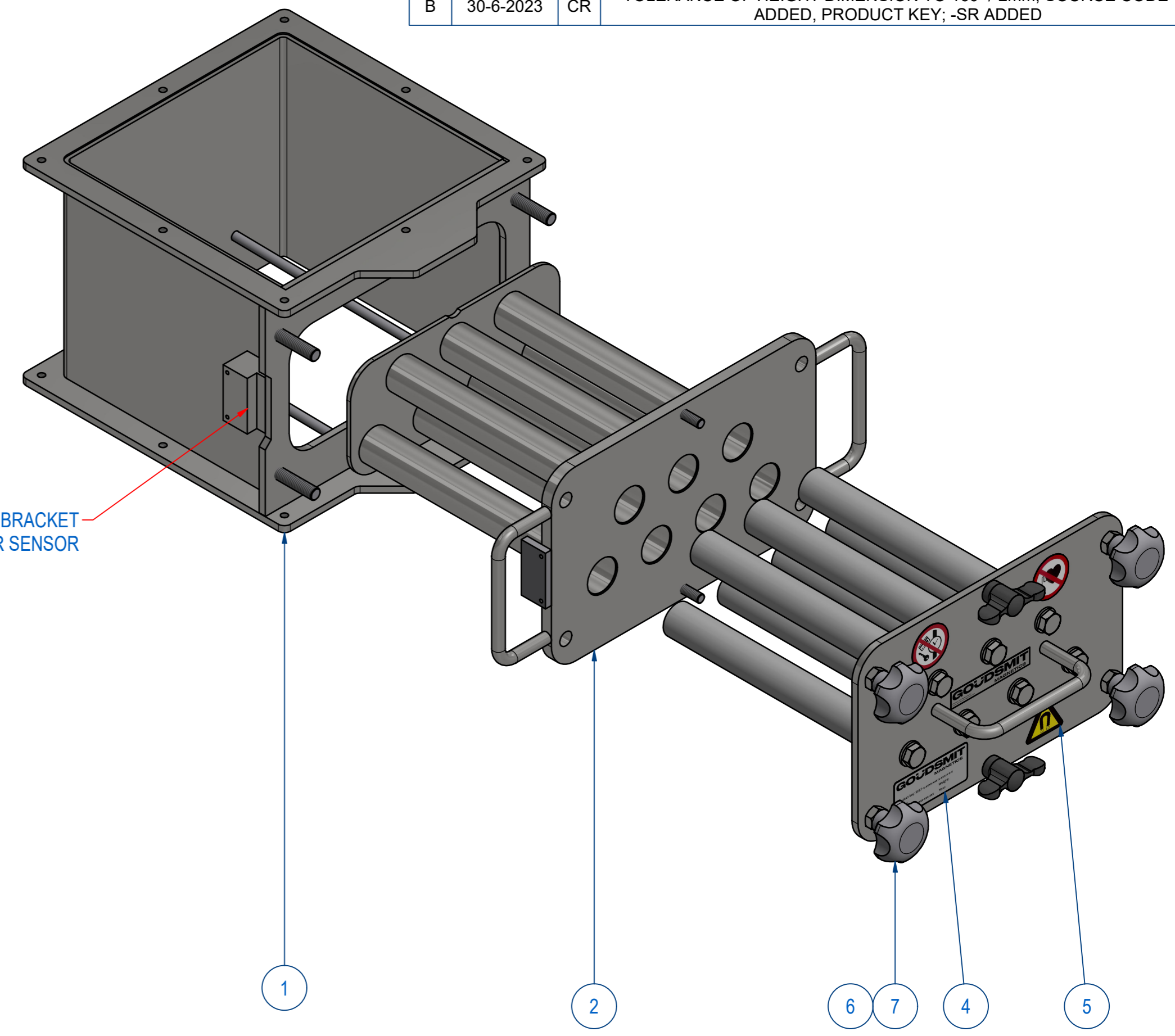

ITEM	QTY	PART NUMBER	DESCRIPTION	Dimensions
7	4	1005.10022	KNOB M8 SS STAR	
6	4	60.0300008	NUT, HEX M8 - A4	M8
5	1	E0093535	STICKERS FOR SECF99 2+3B	
4	2	E0086350	TYPE PLATE SECF	
3	1	E0010565	SECFP-S-1818-SEAL SILI RED EC1935	
2	1	A250753	SECFP-S-1818 INSERT 7B D23/D25	
1	1	A250752	SECFP-1818-HOUSE	

RAW MAT.	Quantity	Material Number	Material Description	Length (mm)	Width (mm)
⊕	1				

Sheet: A2	Extra info:	General tolerance: ISO 2768 - mK
Drawn: CR	Weight (kg): 13	Drawn according: ISO268; ISO1101; ISO2553
Date: 12-7-2019		Status: Standard
Spare part: False	Source: MC-C	Customer reference number:
Quick search: CFP180	<p>© All rights reserved. Reproduction is not permitted without written permission of GOUDSMIT Magnetic Systems BV</p>	
Description: SECF-P-1818-07E-N-F1m-W-B-B-SR		
	Part number: SECFP18030	Rev: B