

REV	DATE	BY	DESCRIPTION
-	25-6-2014	AvD	NEW REVISION VAULT, NOTHING CHANGED, OLD REV WAS A
A	11-8-2023	CR	SOURCE CODE ADDED, -SR ADDED TO PRODUCT KEY (SILICON RED SEAL)

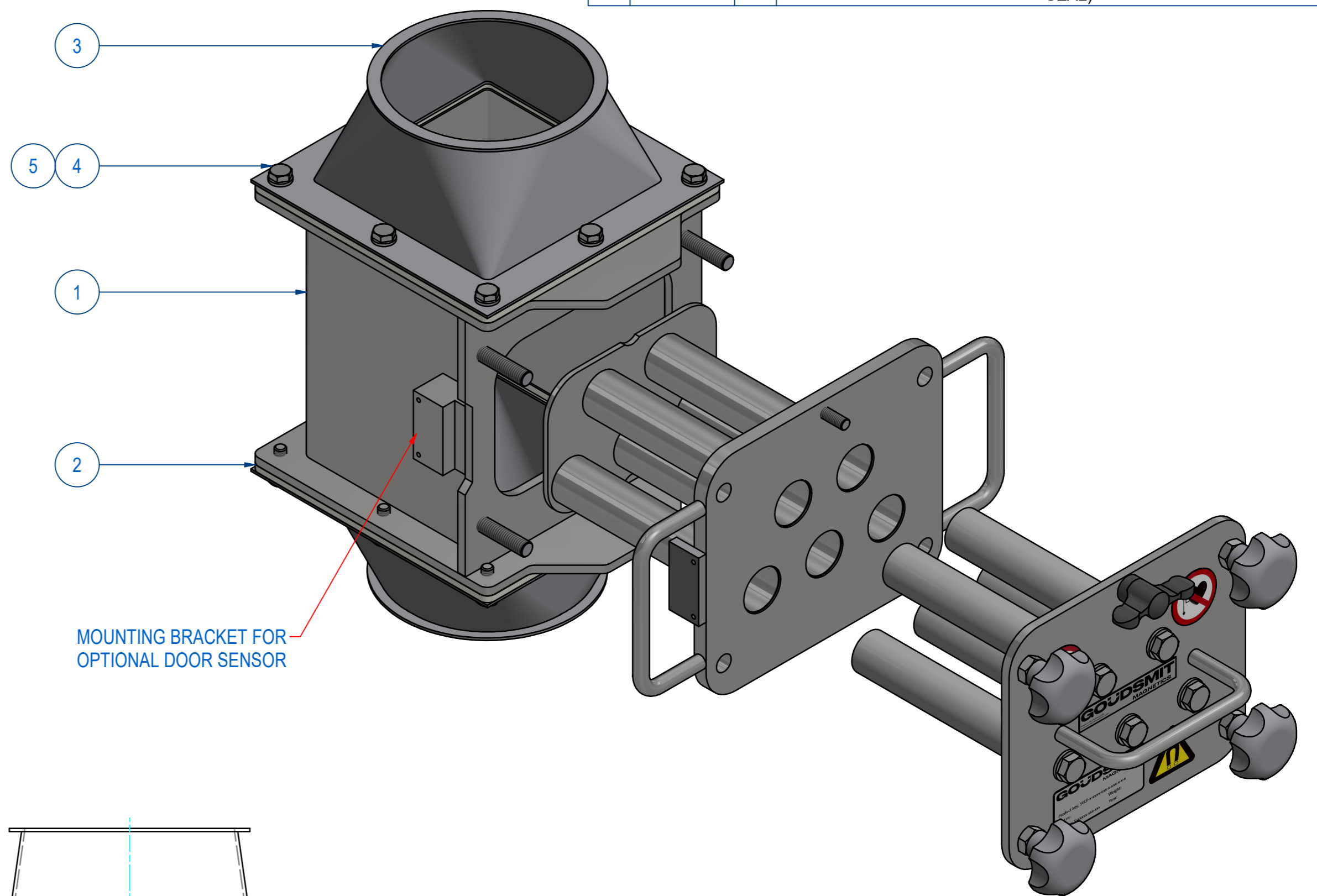
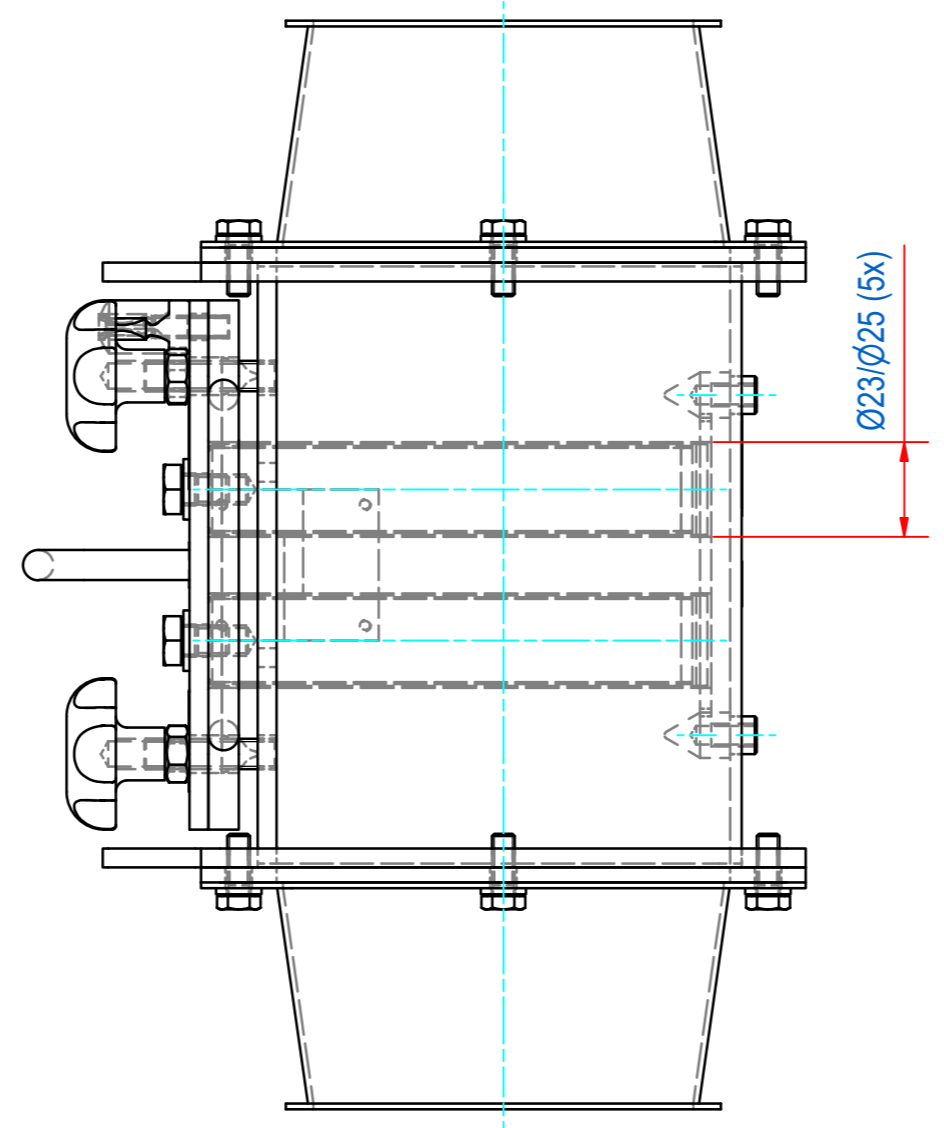
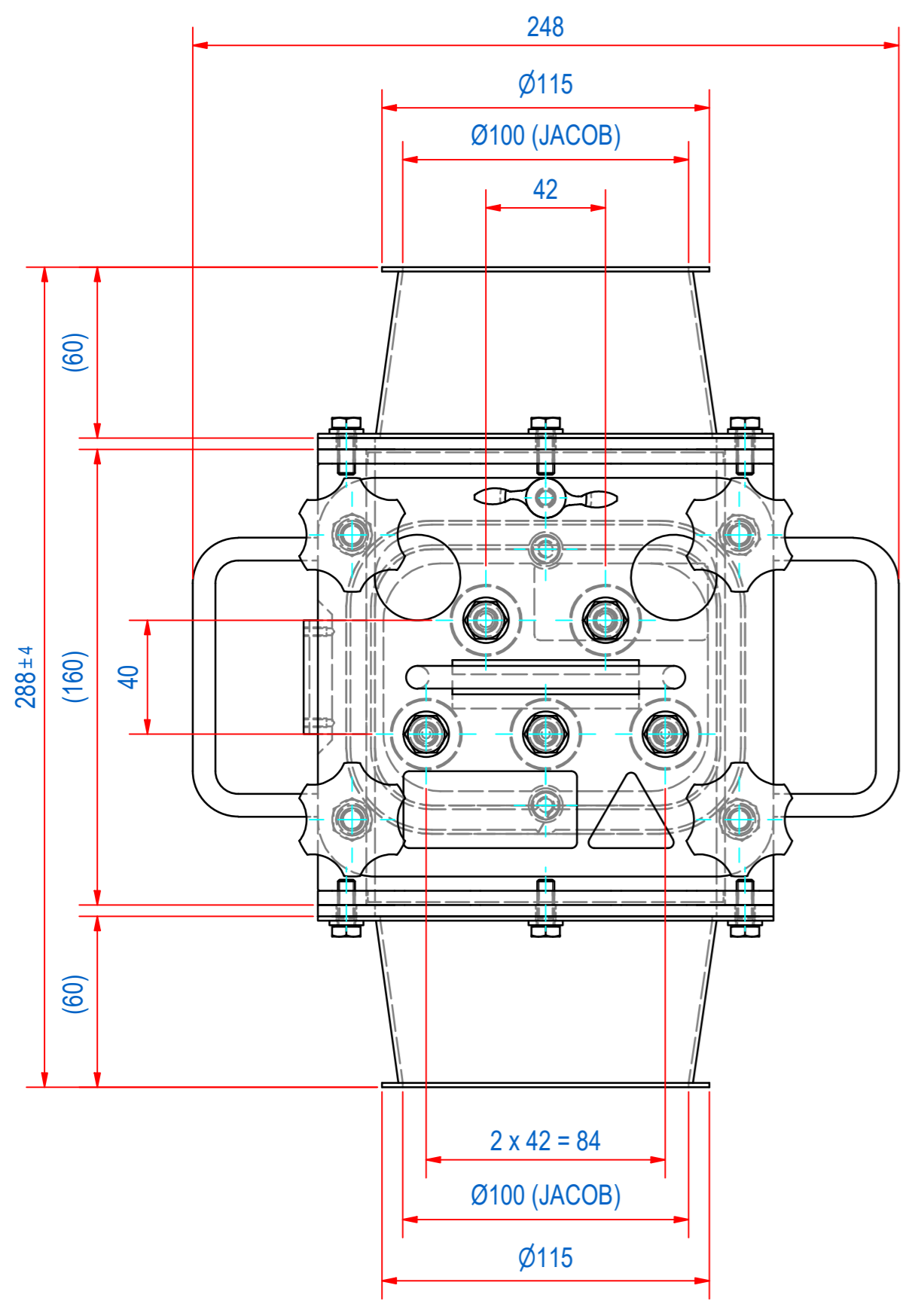
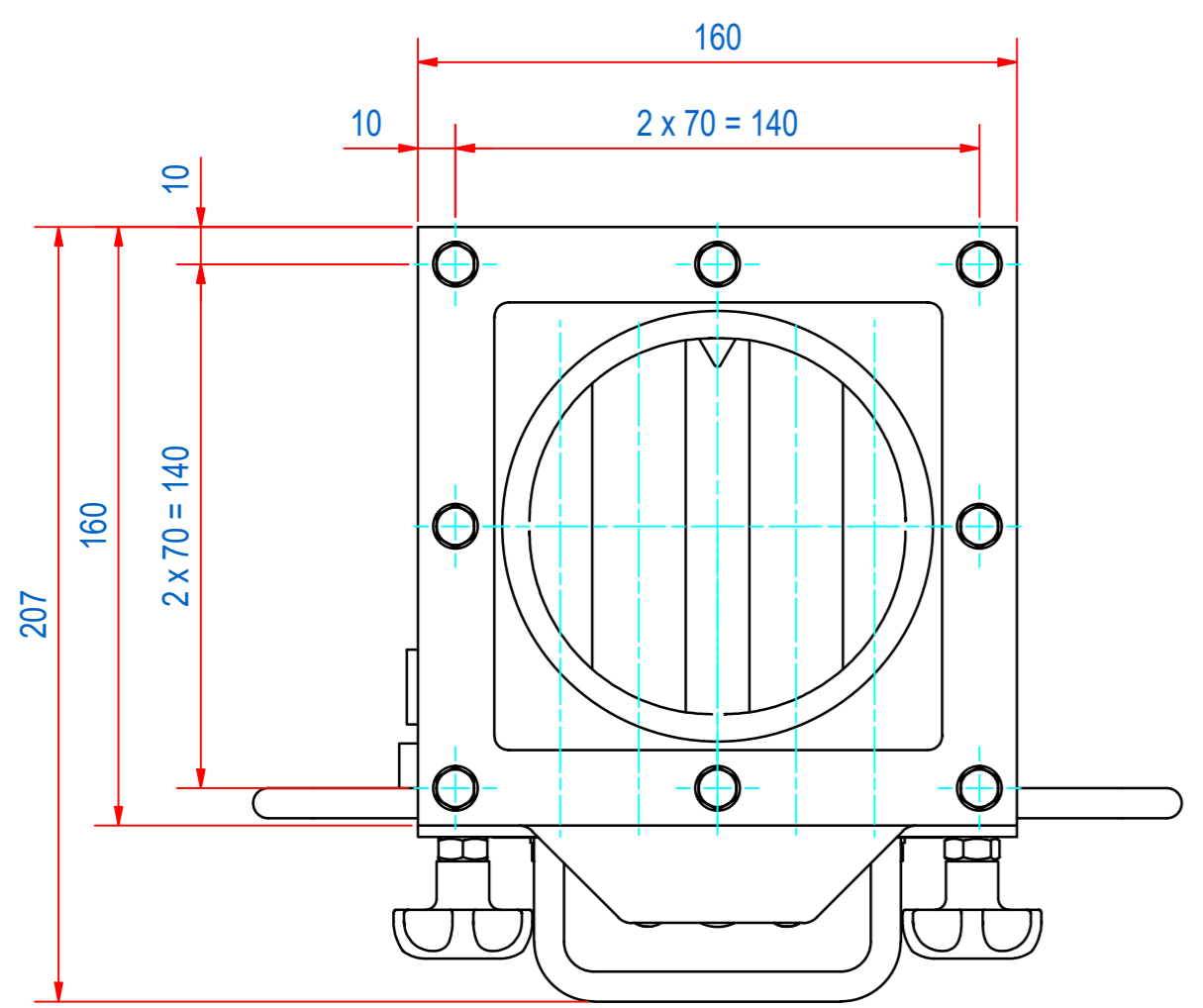

MOUNTING BRACKET FOR
OPTIONAL DOOR SENSOR

ITEM	QTY	PART NUMBER	DESCRIPTION	Dimensions
5	16	70.0300006	WASHER M6 - A4	M6
4	16	50.1306016	BOLT, HEX M6x16-A4	M6 x 16
3	2	95.1009910	JACOB RED #120-D100 H60 316L	
2	2	P250262	GASKET CFP100 EC1935	
1	1	SECFP12030	SECF-P-1212-05E-N-F1m-W-B-B-SR	

RAW MAT.	Quantity	Material Number	Material Description	Length (mm)	Width (mm)
⊕	1				

Sheet:	A2	Extra info:	General tolerance:	ISO 2768 - mK	
Drawn:	CR	Weight (kg):	9,4	Drawn according:	ISO286; ISO1101; ISO2553
Date:	18-10-2012	Status:	Standard	Customer reference number:	
Spare part:	False	Source:	MC-C	Document number:	SECFQ10030
Quick search:	CFQ100	Doc.Rev:	A	Part number:	SECFQ10030
Description:	SECF-P-D100-05E-N-F1m-W-B-B-SR	Rev:	A		



© All rights reserved. Reproduction is not permitted without written permission of GOUDSMIT Magnetic Systems BV