

REV	DATE	BY	DESCRIPTION
A	20-3-2018	TT	WEIGHT CHANGED OF DRIVE- AND RETURN ROLLER
B	9-5-2018	TT	HOLES ADDED FOR GREASING SYSTEM, TYPE PLATE ADDED
C	29-5-2018	TT	REDUNDANT ANNOTATIONS AND SPECIFICATIONS REMOVED

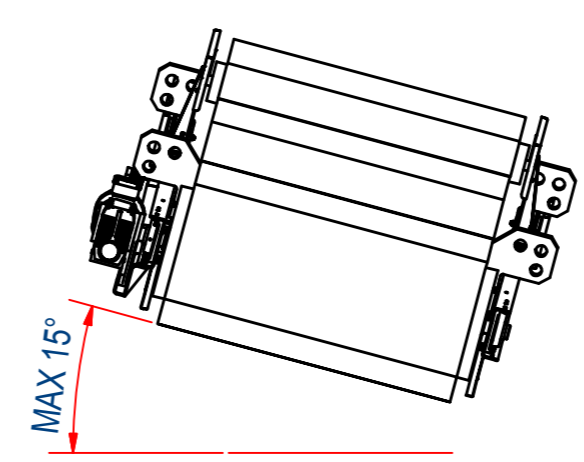
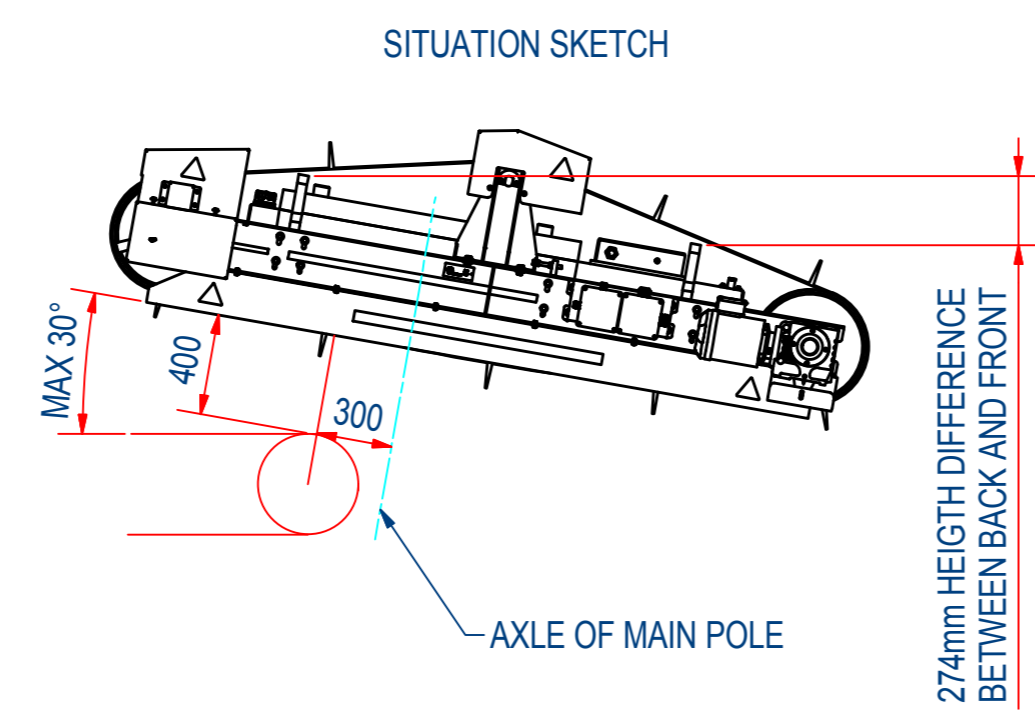
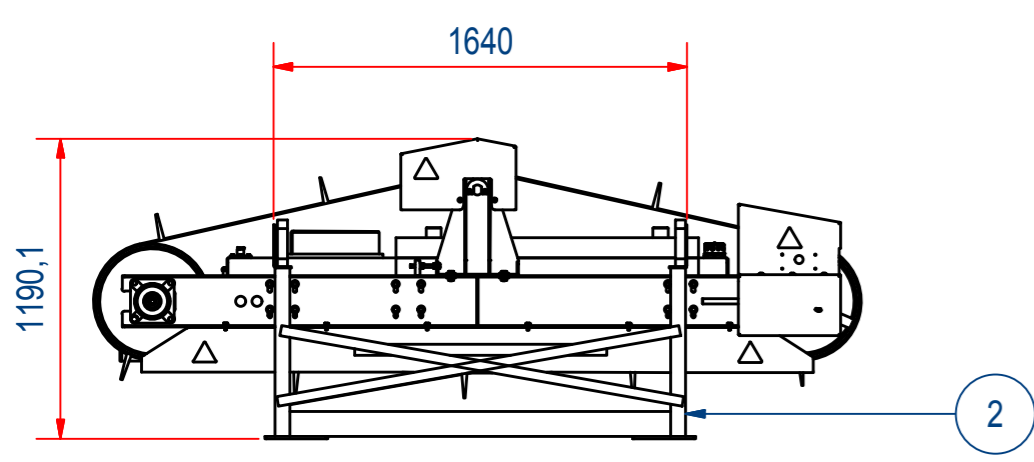
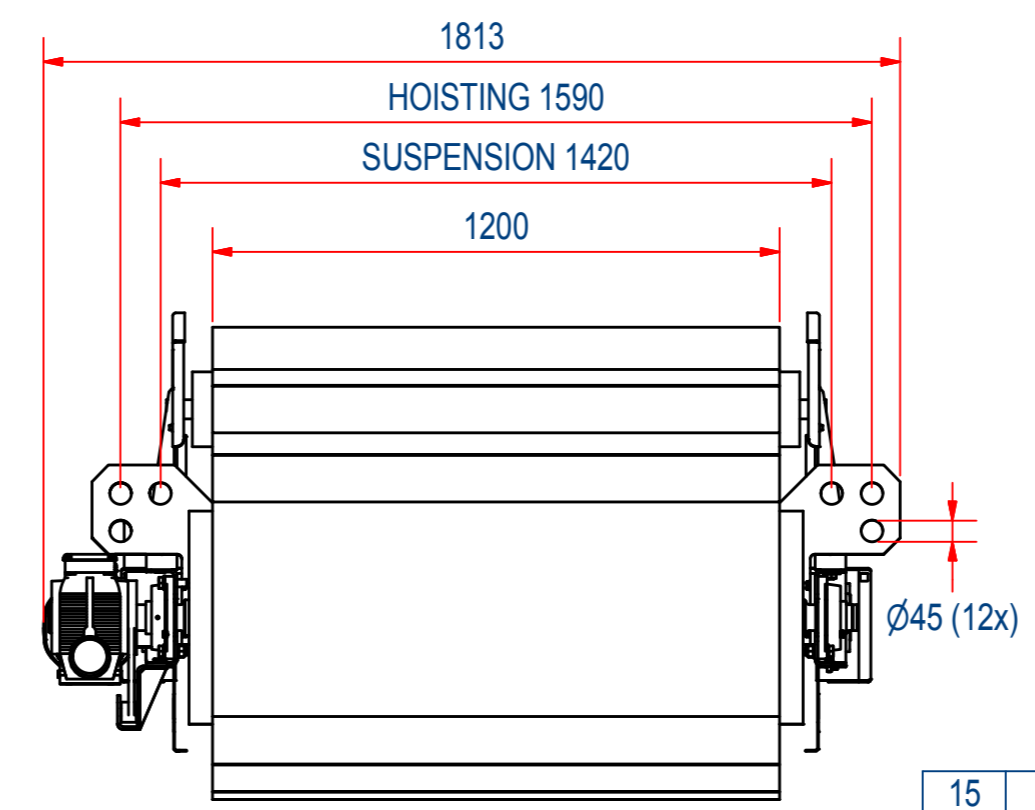
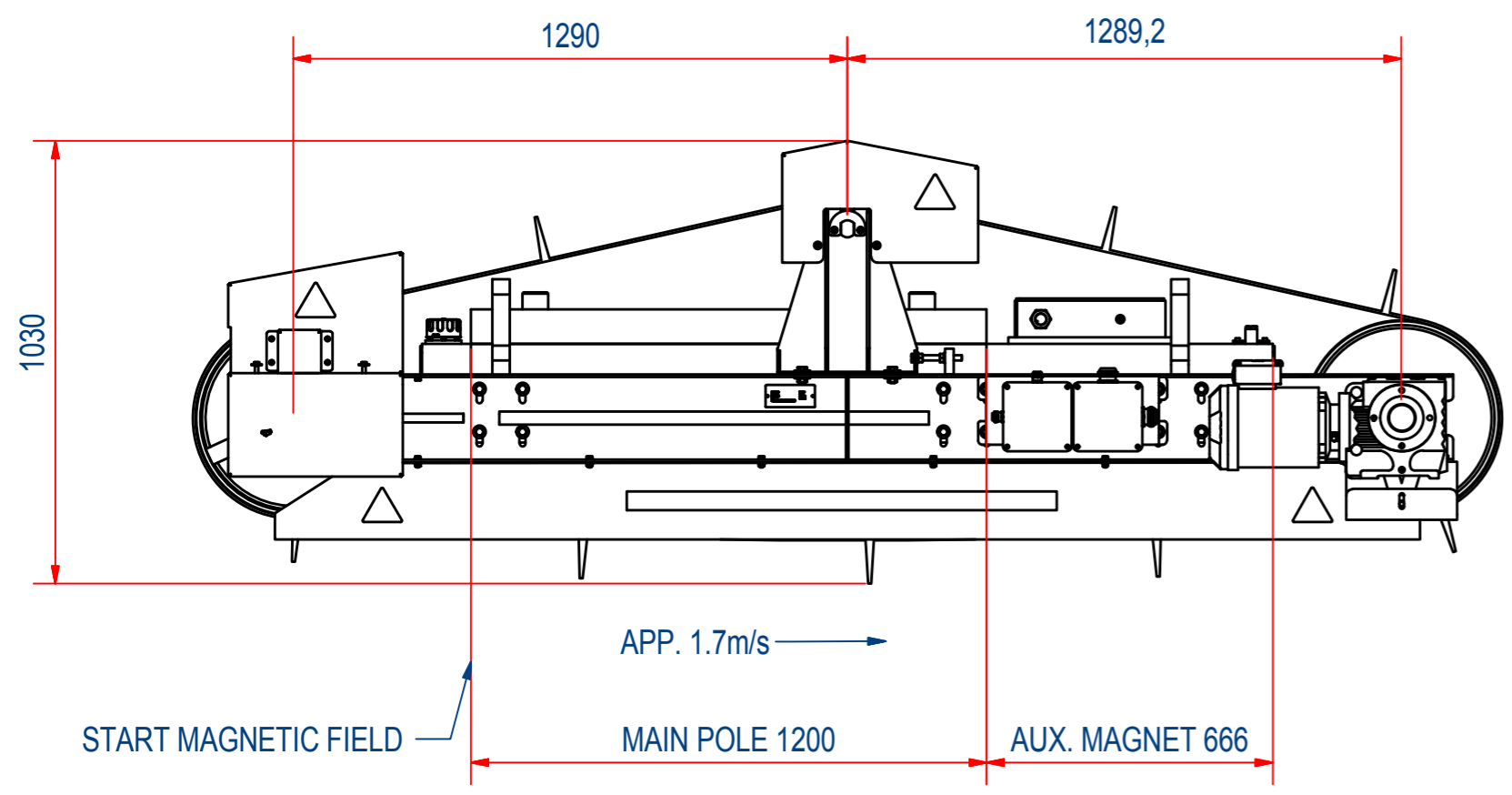
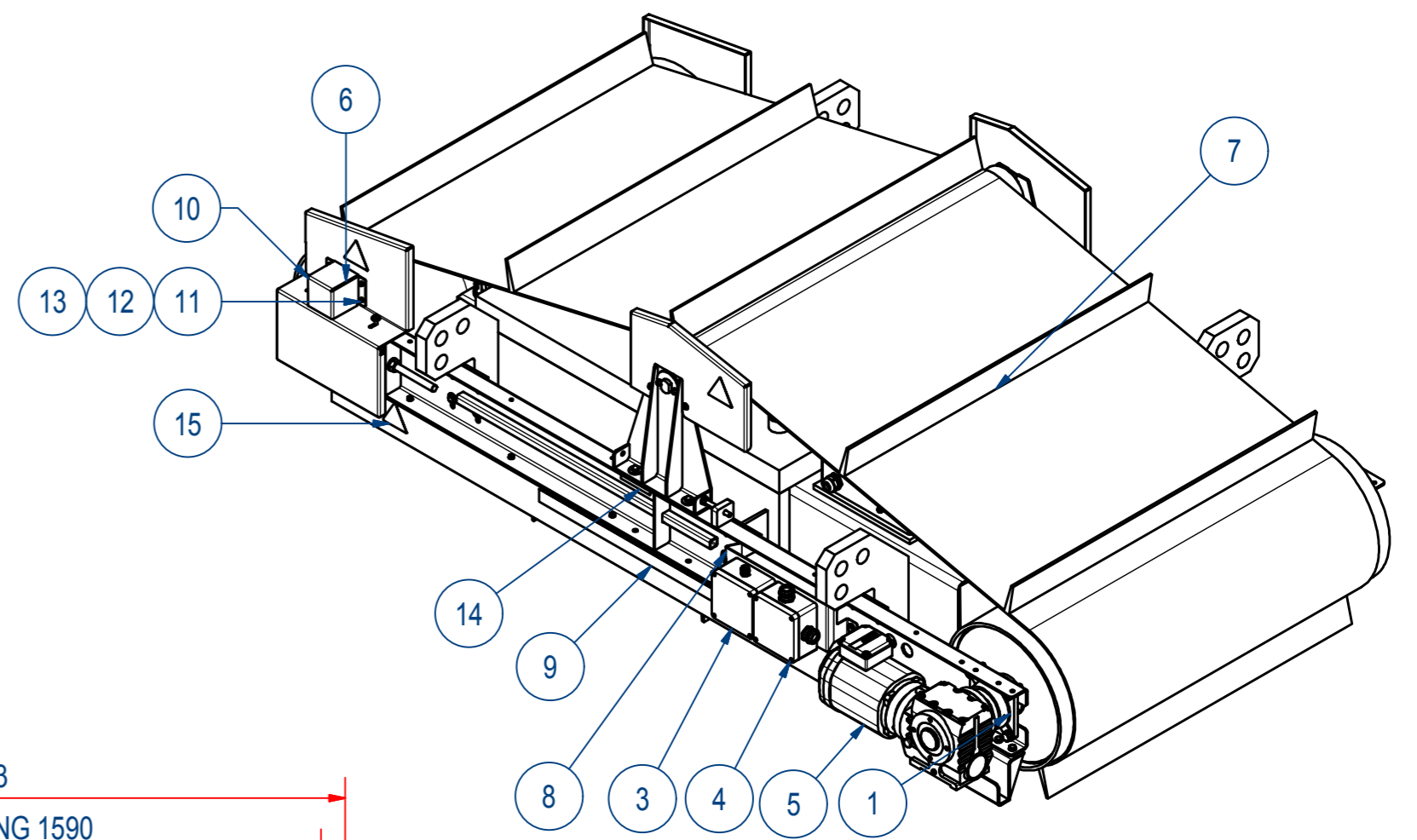
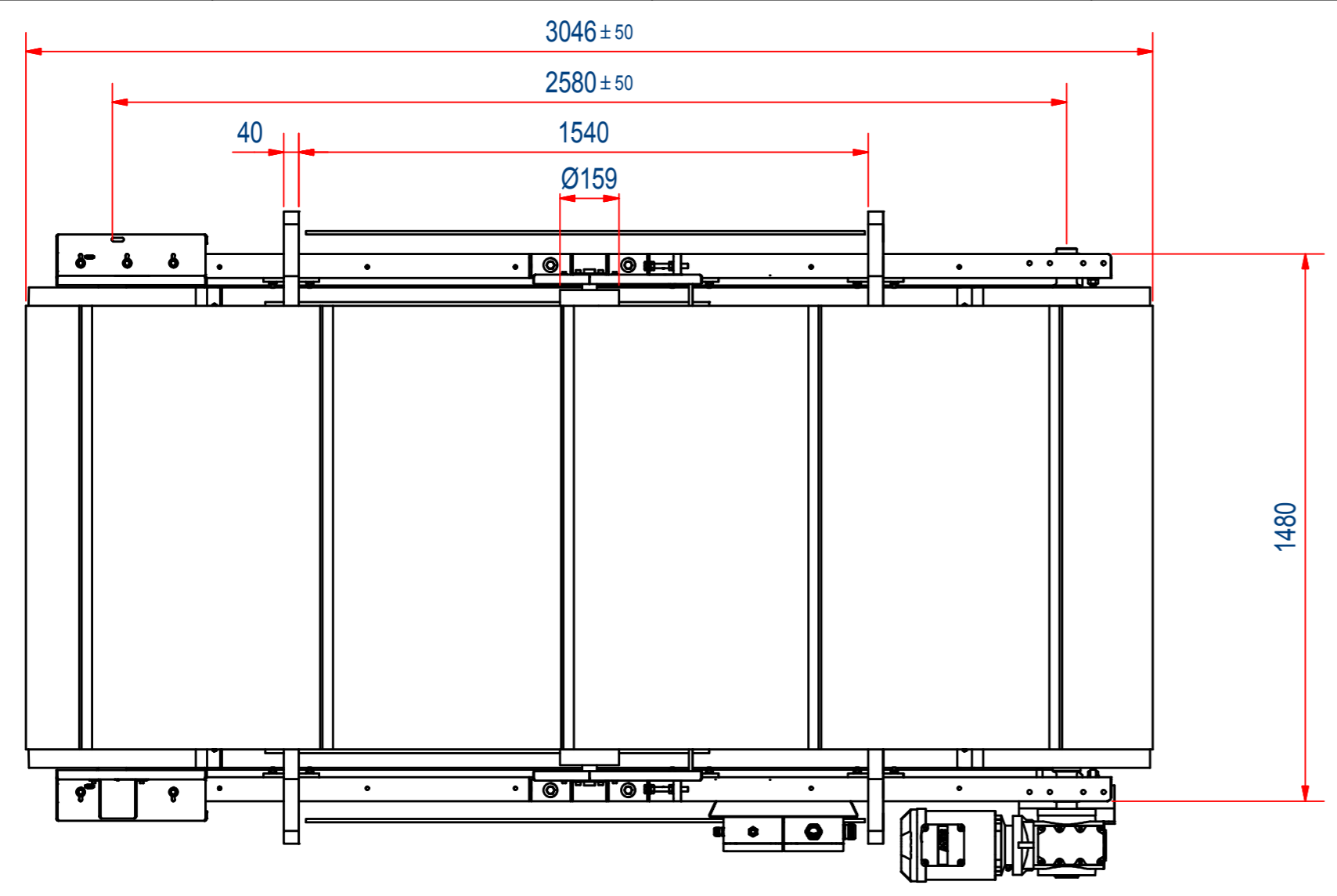

ITEM	QTY	PART NUMBER	DESCRIPTION	Dimensions
15	8	1000.20074	STICKER MAGNET CLAMPING 90mm	
14	1	E0093913	DATA PLATE SEEB	
13	4	60.0100006	NUT, HEX M6 - St8 Zn	M6
12	4	51.0106016	SCREW, HEX SH M6 x 16 - St8.8 Zn	M6 x 16
11	4	70.0100006	WASHER M6 - St.Zn	M 6
10	1	E0010085	COVER SENSOR	
9	2	E0062764	STICKER WEBSITE W1000x43MM	
8	1	E0030039	SUPPORT CONNECTION BOX SEEB	
7	1	45.1120012	CONV.BELT EP400/3 4+2 W:1200	
6	1	EITA036049	PROX SW M30 ROT XSAV11373EX 2D	
5	1	MO22006901	SEW SA67-T-DRE100M4 69rpm	
4	1	E0026685	ASSY DRAW. CONN. BOX 1 SEEB	
3	1	E0026689	ASSY DRAW. CONN. BOX 2 SEEB	
2	1	M13346	TRANSPORT FRAME EB1200	
1	1	E0009698	ASSY ELEC. OVERBELD MAGN. EB1200	

RAW MAT.	1				
QTY		MAT. NUMBER	MAT. DESCRIPTION	LENGTH (mm)	WIDTH (mm)
Sheet: A2		Extra info: 7,6kW / 5,6kW SPEED BELT 1.7m/s		General tolerance: ISO 2768 - mK	
Drawn: BS	Weight (kg): 4149,4	Date: 12-11-2013		Drawn according: ISO268; ISO1101; ISO2553	
Spare part: False		Quick search: ROE-06-C-120		Status: Released	
Description: ROE-06-C-120-W-G-R-B-R-B-B-NA		Goudsmit MAGNETIC SYSTEMS		Customer reference number:	
		© All rights reserved. Reproduction is not permitted without written permission of GOUDSMIT Magnetic Systems BV		File number: SEEB120023	
				Part number: SEEB120023	
				Rev: C	
				Rev: C	