

REV	DATE	BY	DESCRIPTION
-	28-2-2014	CR	NEW REVISION VAULT, NOTHING CHANGED, OLD REV WAS B
A	23-5-2016	CR	KNOB ADDED FOR SECURING FRONT PLATE ON GRID
B	3-3-2022	AvD	E0028964 AND 70.4200006 MOVED TO UNDERLYING DRAWING, TYPE PLATE ADDED, MATERIAL CHANGED INTO AISI316L, PRODUCT KEY CORRECTED.

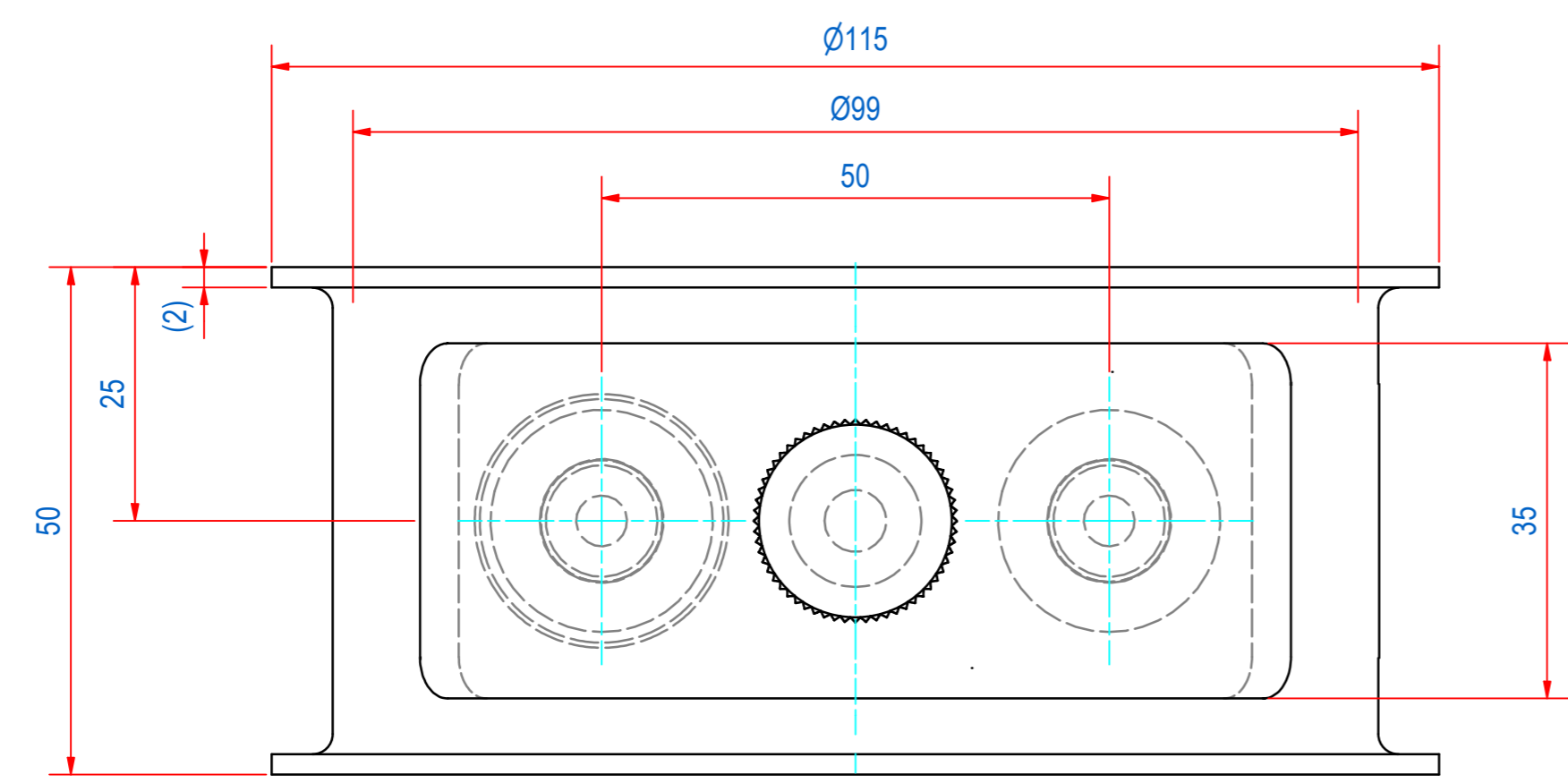

ITEM	QTY	PART NUMBER	DESCRIPTION	Dimensions
4	1	E0150276	STICKER MAGN FIELD 30MM SMR-JF-D100	
3	1	E0150249	TYPE PLATE SMR-JF-D100-HOUSE	
2	1	E0150244	TYPE PLATE SMR-JF-D100-INSERT	
1	1	A110021	SMR-N-D100x50-JF-02E GRID ASSY	
RAW MAT.	1			0 0
Quantity		Material Number	Material Description	Length (mm) Width (mm)
Sheet: A2		Extra info: MAGNETIC GRID		General tolerance: ISO 2768- mK
Drawn: CR		Weight (kg): 1,0		Drawn according: ISO286; ISO1101; ISO2553
Date: 4-7-2014		Source: MC-C		Status: Standard
Spare part: False		Quick search: MRNB0100		Customer reference number:
Description: SMR-N-D100x50-JF-02E-S6-S		Document number: SEMR010078		Doc.Rev: B
		Part number: SEMR010078		Rev: B

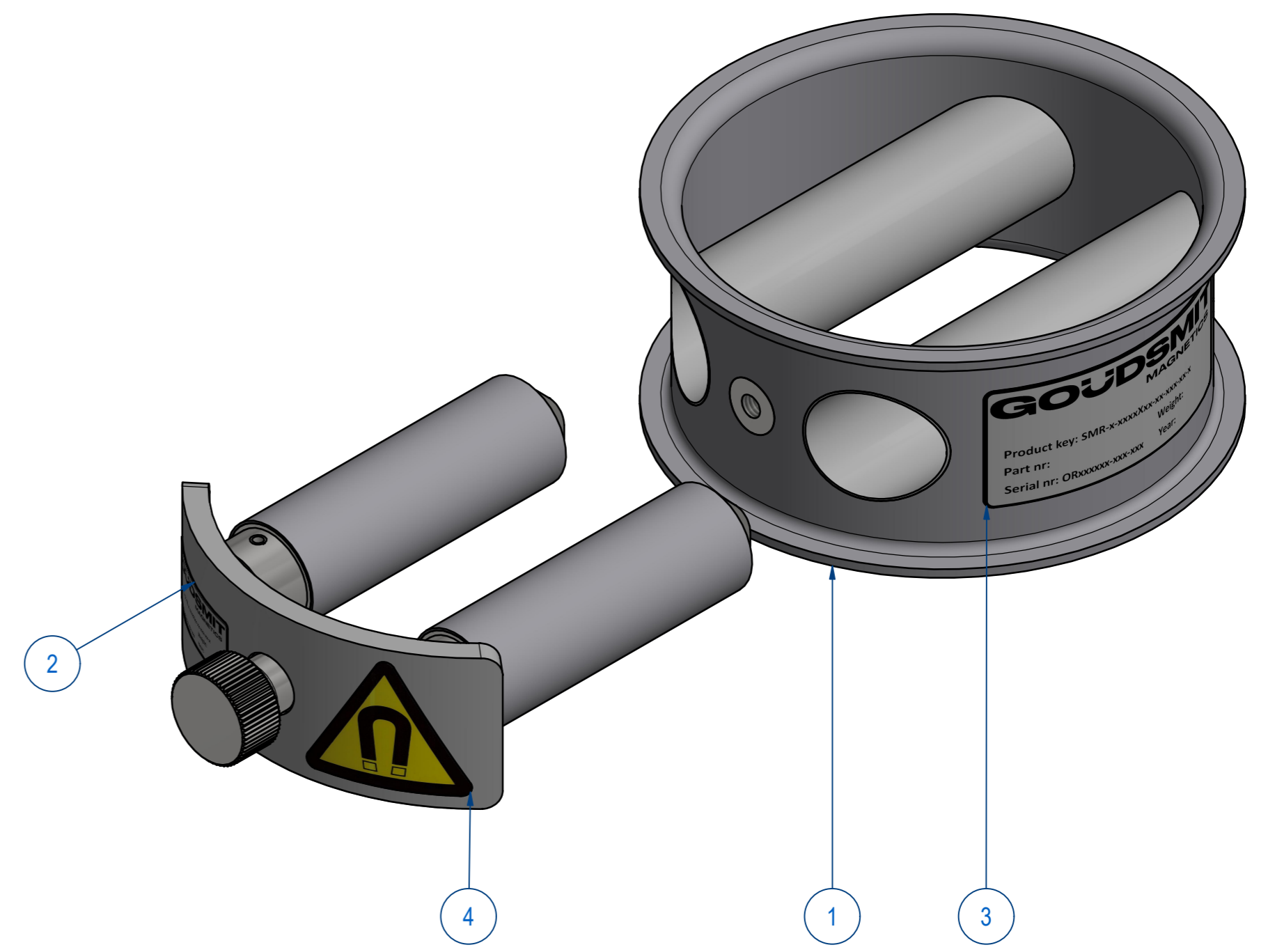
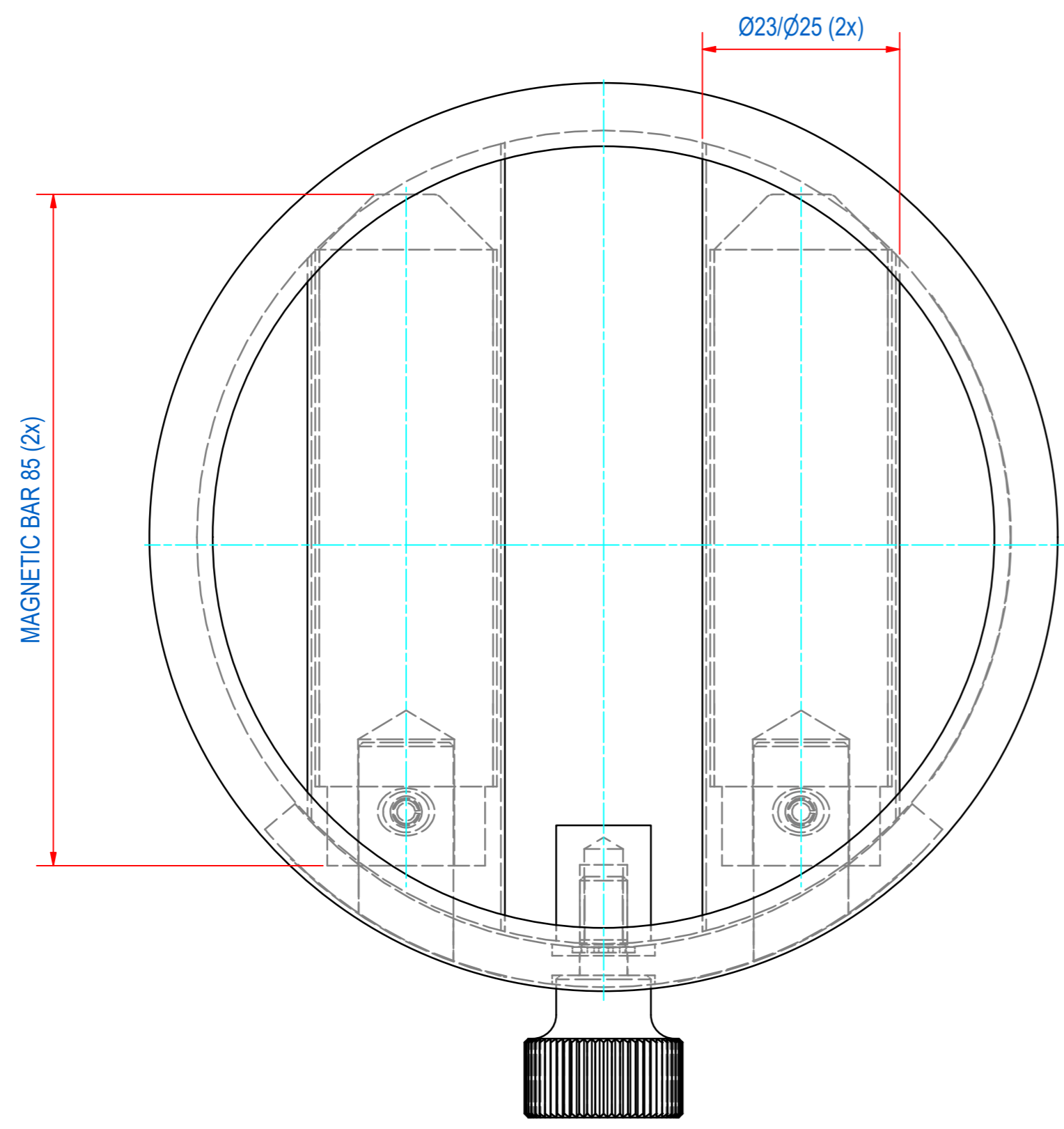

© All rights reserved. Reproduction is not permitted without written permission of GOUDSMIT Magnetic Systems BV